

The SYN43711 integrates Wi-Fi™ 6/6E and Bluetooth™ 5.3 radios on a single state-of-the-art system on chip (SoC) to reduce the space, cost, power, complexity, and time to market of wirelessly enabled IoT devices. The Wi-Fi radio is IEEE 802.11ax compliant with legacy support for 802.11a/b/g/n/ac and has a 1 x 1 antenna arrangement for a throughput of up to 600 Mbps. The Bluetooth 5.3 radio features LE Audio for multiple concurrent Bluetooth audio streaming connections.

BENEFITS

- ▶ High integration reduces footprint, cost, power, complexity, and time to market.
- ▶ 2.4 GHz and 5 or 6 GHz bands simultaneously with up to 600 Mbps throughput.
- ▶ Allows multiple concurrent Bluetooth connections and audio streams.
- ▶ Advanced Wi-Fi/Bluetooth radio co-existence.

APPLICATIONS

- ▶ Multimedia streaming for smart home
- ▶ Wireless home security cameras
- ▶ Premium appliances
- ▶ Drones
- ▶ Robots
- ▶ Automotive Infotainment systems
- ▶ Smart factories/industry 4.0



PERFORMANCE AND COST OPTIMIZED



ROBUST, HIGH-PERFORMANCE WI-FI



BEST WI-FI AND BLUETOOTH COEXISTENCE



LOW SYSTEM COST FOR IOT



FEATURES

- ▶ Supports Wi-Fi 2.4/5/6/6E with best CMOS RF, including integrated PAs and LNAs (external PA and LNA optional) with highest transmit (Tx) power level and receive (Rx) sensitivity.
- ▶ Integrated Bluetooth 5.3 with support for Bluetooth Low Energy (BLE).
- ▶ LE Audio support.
- ▶ Synaptics Smart Co-Ex for best-in-class coexistence of Wi-Fi and Bluetooth radios in the 2.4 GHz band.
- ▶ Measures 5.41mm x 4.24 mm x 0.51mm and comes in two WLBGA packages: standard and plated-through-hole (PTH).

SYSTEM BLOCK DIAGRAM

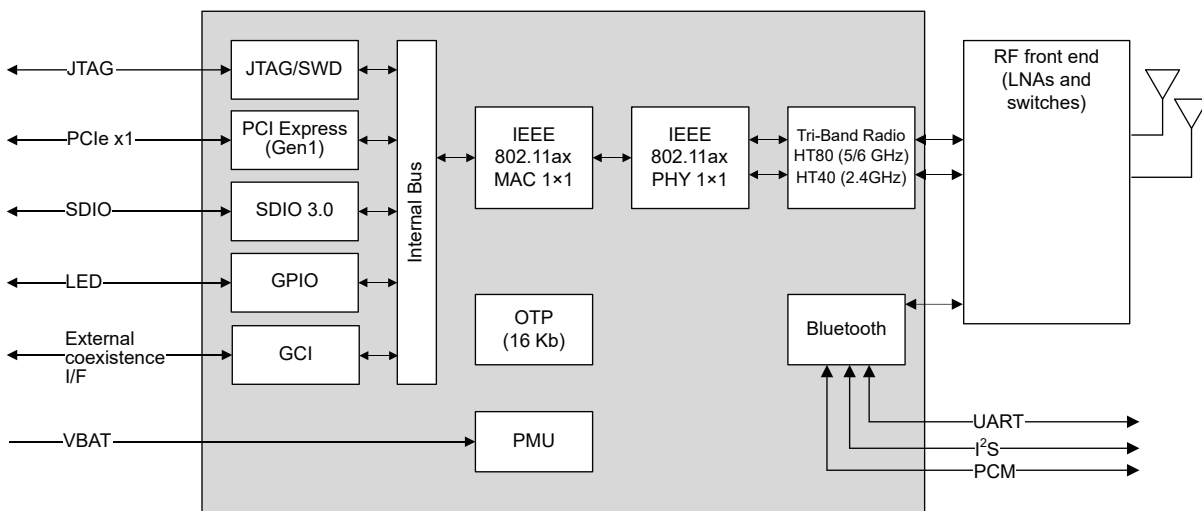

SYN43711 block diagram

TRADEMARKS

Synaptics and the Synaptics logo are trademarks or registered trademarks of Synaptics Incorporated or its affiliates in the United States and/or other countries.

All other marks are the property of their respective owners.

NOTICE

Use of the materials may require a license of intellectual property from a third party or from Synaptics. This document conveys no express or implied licenses to any intellectual property rights belonging to Synaptics or any other party. Synaptics may, from time to time and at its sole option, update the information contained in this document without notice.

INFORMATION CONTAINED IN THIS DOCUMENT IS PROVIDED "AS-IS," WITH NO EXPRESS OR IMPLIED WARRANTIES, INCLUDING ANY IMPLIED WARRANTIES OF MERCHANTABILITY AND FITNESS FOR A PARTICULAR PURPOSE, AND ANY WARRANTIES OF NON-INFRINGEMENT OF ANY INTELLECTUAL PROPERTY RIGHTS. IN NO EVENT SHALL SYNAPTICS BE LIABLE FOR ANY DIRECT, INDIRECT, INCIDENTAL, SPECIAL, PUNITIVE, OR CONSEQUENTIAL DAMAGES ARISING OUT OF OR IN CONNECTION WITH THE USE OF THE INFORMATION CONTAINED IN THIS DOCUMENT, HOWEVER CAUSED AND BASED ON ANY THEORY OF LIABILITY, WHETHER IN AN ACTION OF CONTRACT, NEGLIGENCE OR OTHER TORTIOUS ACTION, AND EVEN IF SYNAPTICS WAS ADVISED OF THE POSSIBILITY OF SUCH DAMAGE. IF A TRIBUNAL OF COMPETENT JURISDICTION DOES NOT PERMIT THE DISCLAIMER OF DIRECT DAMAGES OR ANY OTHER DAMAGES, SYNAPTICS' TOTAL CUMULATIVE LIABILITY TO ANY PARTY SHALL NOT EXCEED ONE HUNDRED U.S. DOLLARS.