

LAN4VSOS24151C2 non-PoE 5G Base-T

TITLE: LAN non-PoE Transformer /5G BASE-T

REV A

CONTENTS

SECTION	DESCRIPTION	PAGE
1	PRODUCT FEATURES AND ENVIRONMENTAL DATA.....	2
	PRODUCT FEATURES	2
	APPLICATIONS	2
	ENVIRONMENTAL DATA.....	2
2	SPECIFICATION	3
2.1	ELECTRICAL PARAMETERS@25°C.....	3
2.2	MECHANICAL PARAMETERS, SCHEMATIC, PAD LAYOUT- MM	4
3	PACKAGING INFORMATION- MM	5
4	RELIABILITY SUMMARY	6
6	SOLDER REFLOW PROFILE	7

LAN4VSOS24151C2 non-PoE 5G Base-T

TITLE: LAN non-PoE Transformer /5G BASE-T

REV A

1 Product features and environmental data

Product features

- IEEE 802.3bz compliant
- 1500 Vac isolation between primary and secondary
- Single port, non-PoE
- Toroid core winding, SMD, Open header
- Weight 1.56g
- Moisture Sensitivity Level (MSL): 1

Applications

- Router
- Network switch
- RJ45 network adapter

Environmental data

Storage temperature range: -40 °C to +125 °C
Operating ambient temperature range: -40 °C to +85 °C
Solder reflow temperature: J-STD-020 (latest revision) compliant
RoHS
REACH
PFOS & PFOA
Halogen free, Sb2O3 and Red Phosphorus

LAN4VSOS24151C2 non-PoE 5G Base-T

TITLE: LAN non-PoE Transformer /5G BASE-T

REV A

2 Specification

2.1 Electrical parameters@25°C

Part Number	Port	Pins	Inductance (uH Min) ¹	Leakage Inductance (uH Max) ¹	DCR (Ω Max) ²	CWW (pF Max) ¹	Turns Ratio ³	Insertion Loss (dB Max) ³	Return Loss (dB Min) ³	Cross Talk (Between each Channel, dB Min)	DCMR (dB Min) ³	Hi-Port (Vac) ³
LAN4VSOS24151C2	Single	24	150 @0mA DC Bias	0.5	1.2	35	1CT:1CT, ±2%	-1 @ 1-100MHz -2 @100-250MHz	-16 @ 1-40MHz -16+10*log(f/40) @40-250MHz	-43.1+20*log(f/100) @ 1-250MHz	-48 @ 1-30MHz -44+19.2*log(f/50) @ 30-250MHz	1500

- Inductance (Transformer side), Leakage Inductance (Transformer side, short CMC side), CWW (Interwinding Capacitance, Pri to Sec): Test parameters: 100KHz, 0.2V
- DCR: CMC side
- Primary to secondary: Polarity pin 1 side in phase
- Part Number Definition: LAN4VSOxxx151xx
 LAN4VSO= LAN Transformer 5G Base-T non-PoE, SMD Open Header
 xxx: S24= Single port, 24Pin
 xx: C2=-40-85°C

LAN4VSOS24151C2 non-PoE 5G Base-T

TITLE: LAN non-PoE Transformer /5G BASE-T

REV A

2.2 Mechanical parameters, schematic, pad layout- mm

LAN4VSOS24151C2

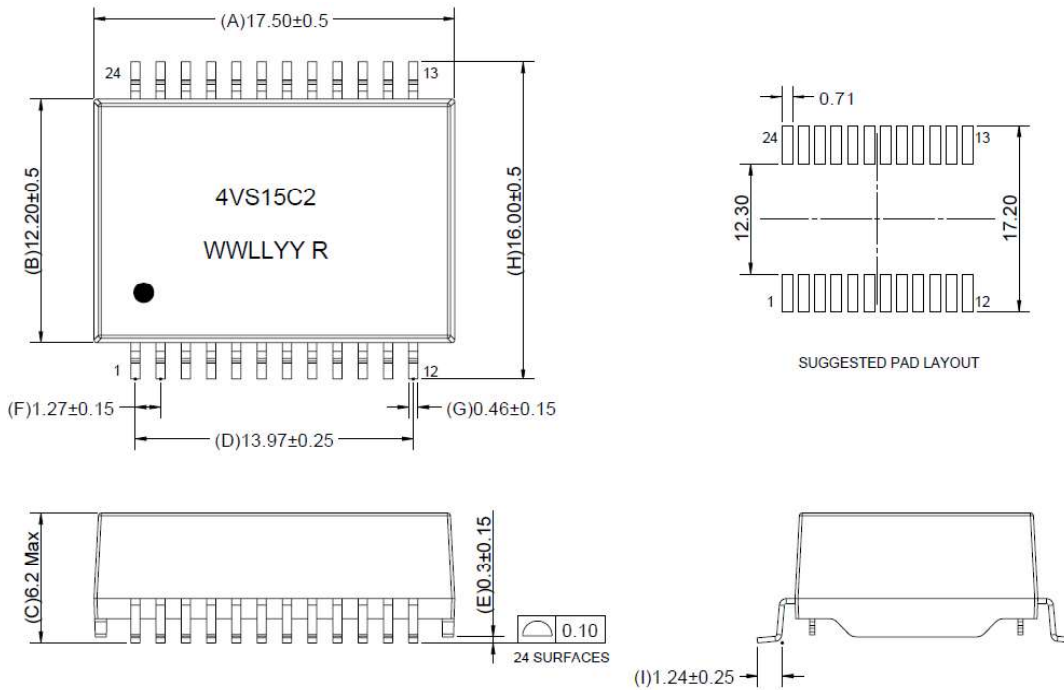

Schematic

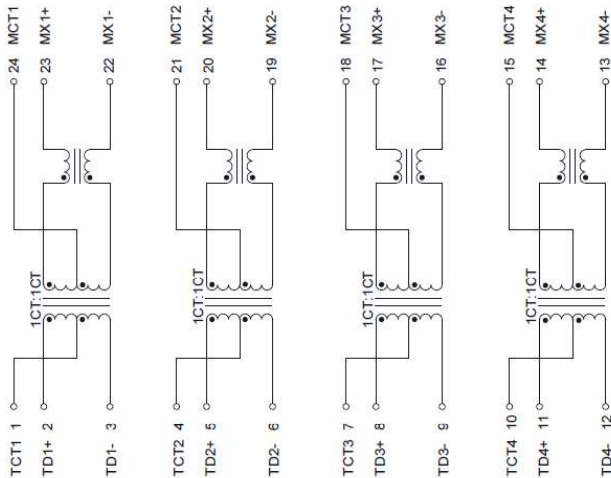

Marking: 4VS15C2 = LAN4VSOS24151C2

WWLLYY R = (Date Code) (Revision)

● is Pin 1 orientation

Pin length don't include solder point

Silkscreen thickness: 0.1-0.15mm

LAN4VSOS24151C2 non-PoE 5G Base-T

TITLE: LAN non-PoE Transformer /5G BASE-T

REV A

3 Packaging information- mm

Supplied in tape and reel packaging, 400 parts per 13" diameter reel, compliant to EIA-481

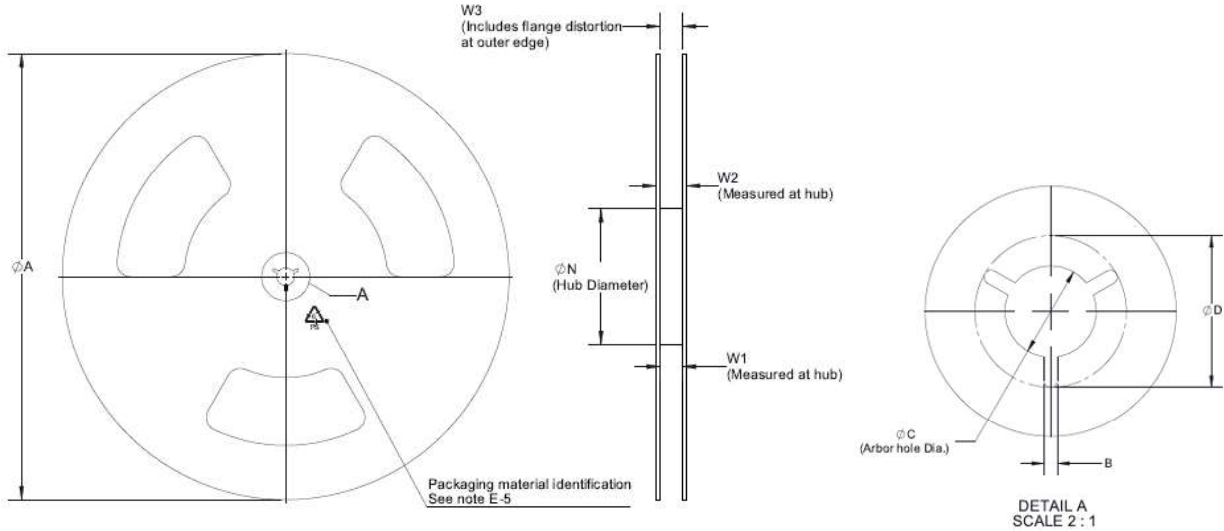

Reel Dimension(mm)

A	B	C	ΦD	N	W1	W2	W3
330±2	1.5min	13+0.5/-0.2	20.2min	100	32.4+2/-0	38.4max	N/A

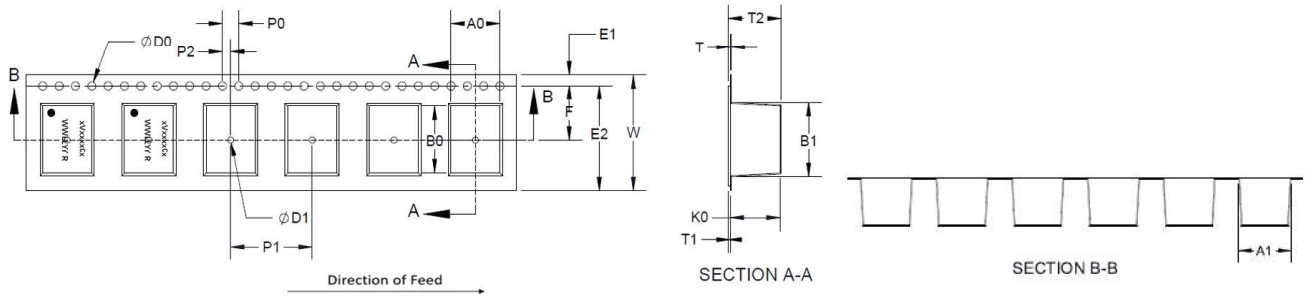

Tape Dimension(mm)

Ao	Bo	Ko	T	W	F	E	E2	P0	P1	P2	ΦD0	D1
17±0.1	17.9±0.1	7.2±0.1	0.5±0.05	32±0.3	14.2±0.1	1.75±0.1	29.85min	4±0.1	20±0.1	2±0.15	1.5+0.1/-0	2.0min

Packaging Quantity

Chip/Reel	Bag	Box	Carton
400	400	400	1600

LAN4VSOS24151C2 non-PoE 5G Base-T

TITLE: LAN non-PoE Transformer /5G BASE-T

REV A

4 Reliability Summary

Test Item	According to	Test Specification	Acceptable Value/Range
External Visual	MIL-STD-883 Method 2009	Inspect device construction, marking and workmanship	Appearance meets the requirements
Pre- and Post-Stress Electrical Test	Product specifications.	Electrical parameters and meet specifications	Test all electrical parameters and meet specifications
Dimensional Measurement	Product specifications.	Dimensional measurement meet specifications.	All dimension meet spec
Solderability	J-STD-002	1. 8 hours steam age test 2. Dip & Look @245°C 5s	The wetting area of the electrode shall be at least 95% covered with new solder coating. (in magnification 50X)
Reflow	MIL-STD-202G	1. IR furnace:260°C ± 5°C, time:30s ± 5s 2. 1 time reflow.	1. No visual damaged. 2. Electrical parameters and meet specifications.
Resistance Soldering Heat	MIL-STD-202H, Method 210	1.Soldering temperature:260°C , 2.Soldering time:10s.	1. No visual damaged. 2. Electrical parameters and meet specifications.
Operational Life	MIL-STD-202, Method 108	1. Environment temperature: 85°C 2. Duration of load:1000h.	1. No visual damaged. 2. Electrical parameters and meet specifications.
Temperature Cycling	MIL-STD-202G	High temperature: 125°C, low temperature - 40°C, conversion time 15 minutes, conversion time 10s, 32 cycles.	1. No visual damaged. 2. Electrical parameters and meet specifications.
Biased Humidity	MIL-STD-202G	1.Temperature: 85°C, Relative Humidity: 85%RH, 2. Duration: 1000 hours.	1. Cumulative corrosion area <10% 2. Electrical parameters and meet specifications.
Vibration	MIL-STD-202, Method 204	1. PSD:10Hz~80Hz Increased at +3dB/octave, 80Hz~350Hz, 0.053g ² /Hz, 350Hz~2000Hz Decrease at -3dB/octave 2. X, Y and Z vibrate for 15 minutes each.	1. No visual damaged. 2. Electrical parameters and meet specifications.
Mechanical Shock	MIL-STD-202, Method 213	1. Waveform: half sine. 2. Acceleration: 50g Pulse duration: 11ms 3. Shock time in each direction :3 times 4. Direction of shock: ±X、±Y、±Z.	1. No visual damaged. 2. Electrical parameters and meet specifications.
Terminal Strength	CBA203A-001	1. Standard: 4.5kg 2. Minimum: 60s	No visual damaged.

LAN4VSOS24151C2 non-PoE 5G Base-T

TITLE: LAN non-PoE Transformer /5G BASE-T

REV A

6 Solder reflow profile

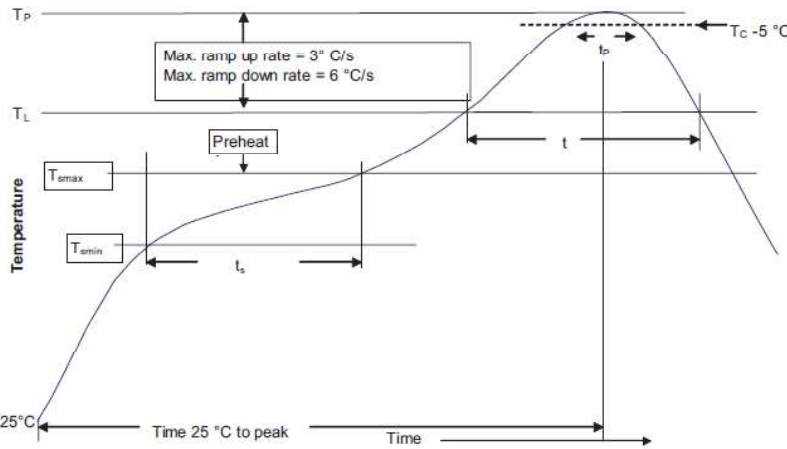

Table 1 - Standard SnPb solder (T_C)

Package Thickness	Volume mm ³ <350	Volume mm ³ ≥350
<2.5 mm)	235 °C	220 °C
≥2.5 mm	220 °C	220 °C

Table 2 - Lead (Pb) free solder (T_C)

Package thickness	Volume mm ³ <350	Volume mm ³ 350 - 2000	Volume mm ³ >2000
<1.6 mm	260 °C	260 °C	260 °C
1.6 - 2.5 mm	260 °C	250 °C	245 °C
>2.5 mm	250 °C	245 °C	245 °C

Reference JDEC J-STD-020

Profile feature	Standard SnPb solder	Lead (Pb) free solder
Preheat and soak		
• Temperature min. (T _{Smin})	100 °C	150 °C
• Temperature max. (T _{Smax})	150 °C	200 °C
• Time (T _{Smin} to T _{Smax}) (t _s)	60-120 seconds	60-120 seconds
Average ramp up rate T _{Smax} to T _P	3 °C/ second max.	3 °C/ second max.
Liquidous temperature (T _L)	183 °C	217 °C
Time at liquidous (t _L)	60-150 seconds	60-150 seconds
Peak package body temperature (T _P)*	Table 1	Table 2
Time (t _p)** within 5 °C of the specified classification temperature (T _C)	10 seconds**	10 seconds**
Average ramp-down rate (T _P to T _{Smax})	6 °C/ second max.	6 °C/ second max.
Time 25 °C to peak temperature	6 minutes max.	8 minutes max.

* Tolerance for peak profile temperature (T_P) is defined as a supplier minimum and a user maximum.
 ** Tolerance for time at peak profile temperature (t_p) is defined as a supplier minimum and a user maximum.