



PRODUCT SPECIFICATION

8266P-PR

Wi-Fi Tri-band 2x2 11ax + BT 5.3

PCIe Combo Module

Version:v1.4

Customer: _____

Customer P/N: _____

Signature: _____

Date: _____

Office: 14th floor, Block B, phoenix zhigu, Xixiang Street, Baoan District, Shenzhen

Factory: NO.8, Litong RD., Liuyang Economic & Technical Development Zone, Changsha, CHINA

TEL:+86-755-2955-8186

Website:www.fn-link.com



8266P-PR Module Datasheet

Ordering Information	Part NO.	Description
	FG8266PPRX-00	QCA2066,DBS 802.11a/b/g/n/ac/ax +BT5.3,2T2R,15x20mm,PCIe/UART,2ant version

2.4G: 17/13.5/13.5/12/10

5.8G: 12.5/11/10/8.5

6G: 12/10/9/7

CONTENTS

1. General Description	5
1.1 Introduction	5
1.2 Description	5
2. Features	6
3. Block Diagram	7
4. General Specification	7
4.1 2.4G RF Specification	7
4.2 5GHz RF Specification	8
4.3 6GHz RF Specification	9
4.4 Bluetooth Specification	10
5. Pin Definition	11
5.1 Pin Outline	11
5.2 Pin Definition details	12
6. Electrical Specifications	14
6.1 Power Supply DC Characteristics	14
6.2 Power Consumption	14
6.3 Interface Circuit time series	15
6.3.1 Powerup sequence timing	15
6.3.2 UART interface	16
6.3.3 PCM interface	18
7. Size reference	20
7.1 Module Picture	20
7.2 Marking Description	20
7.3 Physical Dimensions	21
8. The Key Material List	22
9. Reference Design	22
10. Recommended Reflow Profile	23
11. RoHS compliance	24
12. Package	25
12.1 Reel	25
12.2 Carrier Tape Detail	25
12.3 Packaging Detail	25
13. Moisture sensitivity	26

1. General Description

1.1 Introduction

8266P-PR is a highly integrated single module supporting 2x2 multi-user MIMO 802.11ax Wi-Fi and Bluetooth (BT) Milan.that with WLAN PCI Express network interface controller and HS-UART mixed interface. supporting simultaneous operation on 2.4 GHz and 5 GHz or 6 GHz, also known as Dual Band Simultaneous(DBS). DBS mode provide up to 3 Gbps data rate(2.4G 2x2 11ax+5.8G/6G 2x2 11ax DBS).

1.2 Description

Model Name	8266P-PR
Product Description	Support Wi-Fi/Bluetooth
Dimension	L x W x H: 15 x 20 x 2.4 mm
Wi-Fi Interface	Support PCIe
BT Interface	UART / PCM
OS supported	Android /Linux/ Win CE /iOS /XP/WIN7/WIN10
Operating temperature	0°C to 85°C ¹
Storage temperature	-40°C to 85°C

1. 0° C to -30° C range. module remains the ability for data transmission at lowest data rate.

2. Features

General

- Support IEEE802.11a/b/g/n/ac/ax .
- Supports 2x2 Multi-User Multiple-Input Multiple-Output (MU-MIMO).
- Dual Band Simultaneous (DBS), up to 3 Gbps data rate .
- Support Tri-band 2.4 GHz/5 GHz/6 GHz.
- 20 MHz/40 MHz channel bandwidth for 2.4 GHz and 20MHz/40 MHz/80 MHz/160 MHz channel bandwidth for 5GHz/6 GHz.

Host Interface

- Low-power PCIe (with L1 substate) interface.
- supports PCIe 3 interface for WLAN

Bluetooth Features

- Compliant with Bluetooth Milan .
- Split ACL support for A2DP true stereo.
- Dual Mode support: Simultaneous LE and BR/EDR.
- Flexible interface PCM for Bluetooth audio.
- BT host digital interface:
 - HCI UART

3. Block Diagram

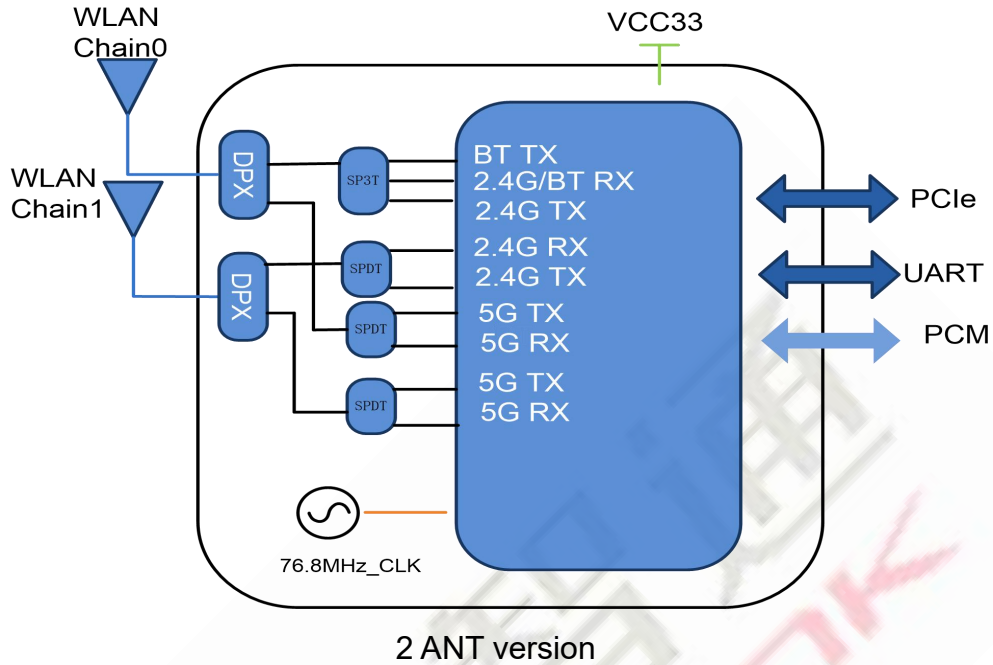

4. General Specification

4.1 2.4G RF Specification

Conditions : VBAT=3.3V ; Temp:25°C

Feature	Description	
WLAN Standard	IEEE 802.11 b/g/n/ac/ax Wi-Fi compliant	
Frequency Range	2.400 GHz ~ 2.4835 GHz (2.4 GHz ISM Band)	
Number of Channels	2.4GHz: Ch1 ~ Ch14	
Test Items	Typical Value	EVM
Output Power ¹	802.11b /11Mbps : 17dBm ± 2 dB	EVM ≤ -9dB
	802.11g /54Mbps : 13.5dBm ± 2 dB	EVM ≤ -25dB
	802.11n HT20/MCS7 : 13.5dBm ± 2 dB	EVM ≤ -28dB
	802.11n HT40/MCS7 : 13dBm ± 2 dB	EVM ≤ -28dB
	802.11ac VHT20/MCS8: 13dBm ± 2 dB	EVM ≤ -30dB
	802.11ac VHT40/MCS9: 12dBm ± 2 dB	EVM ≤ -32dB
	802.11ax HE20/MCS11: 11dBm ± 2 dB	EVM ≤ -35dB
	802.11ax HE40/MCS11: 10dBm ± 2 dB	EVM ≤ -35dB

Spectrum Mask	Meet with IEEE standard		
Freq. Tolerance	± 20ppm		
SISO Receive Sensitivity (11b,20MHz) @8% PER	- 1Mbps @ -94 dBm	≤-83 dBm	
	- 11Mbps @ -85 dBm	≤-76 dBm	
SISO Receive Sensitivity (11g,20MHz) @10% PER	- 6Mbps @ -90 dBm	≤-85 dBm	
	- 54Mbps @ -71 dBm	≤-68 dBm	
SISO Receive Sensitivity (11n,20MHz) @10% PER	- MCS=0 @ -90 dBm	≤-85 dBm	
	- MCS=7 @ -69 dBm	≤-67 dBm	
SISO Receive Sensitivity (11n,40MHz) @10% PER	- MCS=0 @ -87 dBm	≤-82 dBm	
	- MCS=7 @ -66 dBm	≤-64 dBm	
SISO Receive Sensitivity (11ac,20MHz) @10% PER	- MCS=0 @ -90 dBm	≤ -82 dBm	
	- MCS=8 @ -64 dBm	≤ -60 dBm	
SISO Receive Sensitivity (11ac ,40MHz) @10% PER	- MCS=0 @ -87 dBm	≤ -79 dBm	
	- MCS=9 @ -59 dBm	≤ -55 dBm	
SISO Receive Sensitivity (11ax,20MHz) @10% PER	- MCS=0 @ -90 dBm	≤-74 dBm	
	- MCS=11 @ -60 dBm	≤-52 dBm	
SISO Receive Sensitivity (11ax ,40MHz) @10% PER	- MCS=0 @ -87 dBm	≤-71 dBm	
	- MCS=11 @ -57 dBm	≤-49 dBm	
Maximum Input Level	802.11b : -10 dBm		
	802.11g/n : -20 dBm		
Antenna Reference	Small antennas with 0~2 dBi peak gain		

4.2 5GHz RF Specification

Conditions : VBAT=3.3V ; VDDIO=3.3V ; Temp:25°C

Feature	Description	
WLAN Standard	IEEE 802.11a/n/ac/ax, Wi-Fi compliant	
Frequency Range	5.150 GHz ~ 5.850 GHz (5.0 GHz ISM Band)	
Number of Channels	Full band supported	
Test Items	Typical Value	EVM
Output Power ²	802.11a /54Mbps: 12.5 dBm ± 2 dB	EVM ≤ -25dB
	802.11n HT20/MCS7: 11.5 dBm ± 2 dB	EVM ≤ -28dB
	802.11n HT40/MCS7: 11dBm ± 2 dB	EVM ≤ -28dB
	802.11ac VHT20/MCS8: 11 dBm ± 2 dB	EVM ≤ -30dB
	802.11ac VHT40/MCS9: 10.5 dBm ± 2 dB	EVM ≤ -32dB
	802.11ac VHT80/MCS9: 10 dBm ± 2 dB	EVM ≤ -32dB
	802.11ax HE20/MCS11: 10 dBm ± 2 dB	EVM ≤ -35dB
802.11ax HE40/MCS11: 9.5 dBm ± 2 dB	EVM ≤ -35dB	

Test Items	Test Value	Standard Value
	802.11ax HE80/MCS11: 8.5 dBm ± 2 dB	EVM ≤ -35dB
SISO Receive Sensitivity (11a,20MHz) @10% PER	- 6Mbps @ -90 dBm - 54Mbps @ -71 dBm	≤ -85 dBm ≤ -68 dBm
SISO Receive Sensitivity (11n,20MHz) @10% PER	- MCS=0 @ -90 dBm - MCS=7 @ -69 dBm	≤ -85 dBm ≤ -67 dBm
SISO Receive Sensitivity (11n,40MHz) @10% PER	- MCS=0 @ -87 dBm - MCS=7 @ -66 dBm	≤ -82 dBm ≤ -64 dBm
SISO Receive Sensitivity (11ac,20MHz)@10% PER	- MCS=0, NSS1 @ 90 dBm - MCS=8, NSS1 @ -64 dBm	≤ -82 dBm ≤ -60 dBm
SISO Receive Sensitivity (11ac,40MHz) @10% PER	- MCS=0, NSS1 @ -87 dBm - MCS=9, NSS1 @ -59 dBm	≤ -79 dBm ≤ -55 dBm
SISO Receive Sensitivity (11ac,80MHz) @10% PER	- MCS=0, NSS1 @ -84 dBm - MCS=9, NSS1 @ -56 dBm	≤ -79 dBm ≤ -54 dBm
SISO Receive Sensitivity (11ax,20MHz) @10% PER	- MCS=0 @ -90 dBm - MCS=11 @ -58 dBm	≤ -74 dBm ≤ -52 dBm
SISO Receive Sensitivity (11ax,40MHz) @10% PER	- MCS=0 @ -87 dBm - MCS=11 @ -54 dBm	≤ -71 dBm ≤ -49 dBm
SISO Receive Sensitivity (11ax,80MHz) @10% PER	- MCS=0 @ -84 dBm - MCS=11 @ -48 dBm	≤ -68 dBm ≤ -46 dBm
Maximum Input Level	802.11a/n: -30 dBm	
Antenna Reference	Small antennas with 0~2 dBi peak gain	

1. 2. 2.4G,5G output power control by firmware power by rate table, the table value must same with module target power

4.3 6GHz RF Specification

Feature	Description	
WLAN Standard	IEEE 802.11a/n/ac/ax, Wi-Fi compliant	
Frequency Range	5.925 GHz ~ 7.125 GHz	
Number of Channels	Full band supported	
Test Items	Typical Value	EVM
Output Power	802.11a /54Mbps: 12 dBm ± 2 dB	EVM ≤ -25dB
	802.11n HT40/MCS7: 10dBm ± 2 dB	EVM ≤ -28dB
	802.11ac VHT80/MCS9: 9 dBm ± 2 dB	EVM ≤ -32dB
	802.11ax HE20/MCS11: 8 dBm ± 2 dB	EVM ≤ -35dB
	802.11ax HE40/MCS11: 8 dBm ± 2 dB	EVM ≤ -35dB

	802.11ax HE80/MCS11: 7 dBm ± 2 dB	EVM ≤ -35dB
	802.11ax HE160/MCS11: 7 dBm ± 2 dB	EVM ≤ -35dB
Test Items	Test Value	Standard Value
SISO Receive Sensitivity (11a,20MHz) @10% PER	- 6Mbps @ -90 dBm	≤-85
	- 54Mbps @ -71 dBm	≤-68
SISO Receive Sensitivity (11n,20MHz) @10% PER	- MCS=0 @ -90 dBm	≤-85
	- MCS=7 @ -69 dBm	≤-67
SISO Receive Sensitivity (11n,40MHz) @10% PER	- MCS=0 @ -87 dBm	≤-82
	- MCS=7 @ -66 dBm	≤-64
SISO Receive Sensitivity (11ac,20MHz)@10% PER	- MCS=0, NSS1 @ 90 dBm	≤-82
	- MCS=8, NSS1 @ -64 dBm	≤-60
SISO Receive Sensitivity (11ac,40MHz) @10% PER	- MCS=0, NSS1 @ -87 dBm	≤-79
	- MCS=9, NSS1 @ -59 dBm	≤-55
SISO Receive Sensitivity (11ac,80MHz) @10% PER	- MCS=0, NSS1 @ -84 dBm	≤-79
	- MCS=9, NSS1 @ -56 dBm	≤-54
SISO Receive Sensitivity (11ax,20MHz) @10% PER	- MCS=0 @ -90 dBm	≤-74
	- MCS=11 @ -58 dBm	≤-52
SISO Receive Sensitivity (11ax,40MHz) @10% PER	- MCS=0 @ -87 dBm	≤-71
	- MCS=11 @ -54 dBm	≤-49
SISO Receive Sensitivity (11ax,80MHz) @10% PER	- MCS=0 @ -84 dBm	≤-68
	- MCS=11 @ -48 dBm	≤-46
Maximum Input Level	802.11a/n: -30 dBm	
Antenna Reference	Small antennas with 0~2 dBi peak gain	

4.4 Bluetooth Specification

Feature	Description
General Specification	
Bluetooth Standard	Bluetooth V5.3
Host Interface	UART
Antenna Reference	Small antennas with 0~2 dBi peak gain
Frequency Band	2402 MHz ~ 2480 MHz
Number of Channels	79 channels

Modulation	GFSK, $\pi/4$ -DQPSK, 8-DPSK		
RF Specification			
	Min(dBm)	Typical(dBm)	Max(dBm)
Output Power (Class 1)	2	9	15
Sensitivity @ BER=0.1% for GFSK (1Mbps)		-89	
Sensitivity @ BER=0.01% for $\pi/4$ -DQPSK (2Mbps)		-86	
Sensitivity @ BER=0.01% for 8DPSK (3Mbps)		-85	
Maximum Input Level	GFSK (1Mbps):-20dBm		
	$\pi/4$ -DQPSK (2Mbps) :-20dBm		
	8DPSK (3Mbps) :-20dBm		

Note: The BT power control by driver.

5. Pin Definition

5.1 Pin Outline

< TOP VIEW >

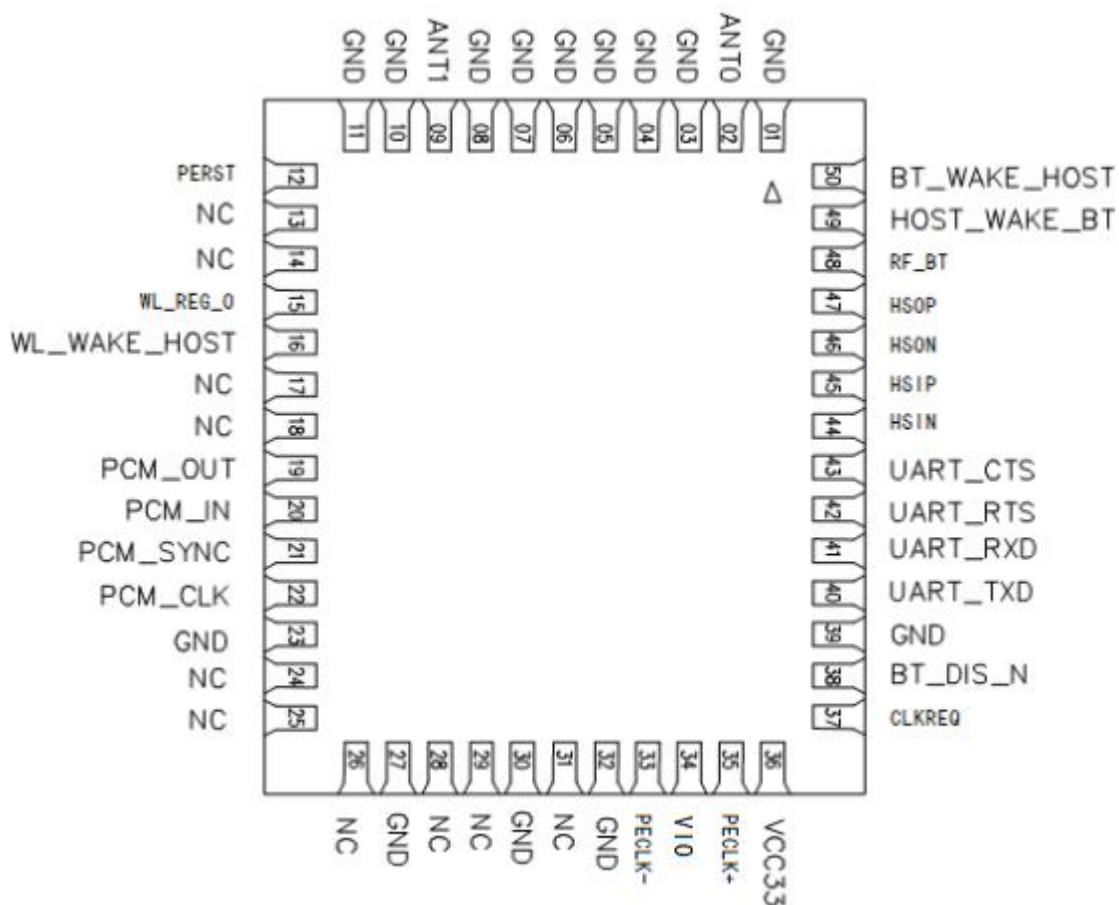

5.2 Pin Definition details

NO.	Name	Type	Description	Voltage
1	GND	—	Ground connections	
2	ANT0	I/O	RF I/O port chain0, Dual band Wi-Fi and BT RX	
3	GND	—	Ground connections	
4	GND	—	Ground connections	
5	GND	—	Ground connections	
6	GND	—	Ground connections	
7	GND	—	Ground connections	
8	GND	—	Ground connections	
9	ANT1	I/O	RF I/O port chain1, dual band Wi-Fi	
10	GND	—	Ground connections	
11	GND	—	Ground connections	

12	PERST	I/O	PCIE reset, GPIO57	1.8V
13	NC	—	No connect	
14	NC	—	No connect	
15	WL_REG_O	I	WL EN, Default ON: 100k pull high; OFF: pull low	1.8V
16	WL_WAKE_HOST	O	WAKE#, WLAN wake-up HOST, GPIO58, active low,External 10Kohm pull up needed.	1.8V
17	NC	—	No connect	
18	NC	—	No connect	
19	PCM_OUT	O	PCM Data output, GPIO5	1.8V
20	PCM_IN	I	PCM data input, GPIO4	1.8V
21	PCM_SYNC	I/O	PCM sync signal, GPIO6	1.8V
22	PCM_CLK	I/O	PCM clock, GPIO7	1.8V
23	GND	—	Ground connections	
24	NC	—	No connect	
25	NC	—	No connect	
26	NC	—	No connect	
27	GND	—	Ground connections	
28	NC	—	No connect	
29	NC	—	No connect	
30	GND	—	Ground connections	
31	NC	—	No connect	
32	GND	—	Ground connections	
33	PECLK-	I/O	PCIE CLK-	1.8V
34	VIO	P	IO power supply	1.8V
35	PECLK+	I/O	PCIE CLK+	1.8V
36	VCC33	P	Main power voltage source input 3.3V	3.3V
37	CLKREQ	I/O	PCIE clk request,GPIO59,external 10 K Ω pull-up Resistor need.	1.8V
38	BT_DIS_N	I	BT EN, Default ON: 100k pull high; OFF: pull low	1.8V
39	GND	—	Ground connections	
40	UART_TXD	O	Bluetooth UART interface, GPIO1	1.8V
41	UART_RXD	I	Bluetooth UART interface, GPIO0	1.8V
42	UART_RTS	O	Bluetooth UART interface, GPIO3	1.8V
43	UART_CTS	I	Bluetooth UART interface, GPIO2	1.8V
44	HSIN	I	PCIE RX-	1.8V

45	HSIP	I	PCIE RX+	1.8V
46	HS0N	O	PCIE TX-	1.8V
47	HS0P	O	PCIE TX+	1.8V
48	RF_BT	—	keep no connection.	
49	HOST_WAKE_BT	I	HOST wake-up Bluetooth device, GPIO10	1.8V
50	BT_WAKE_HOST	O	Bluetooth device to wake-up HOST, GPIO9	1.8V

P:POWER I:INPUT O:OUTPUT

6. Electrical Specifications

6.1 Power Supply DC Characteristics

	MIN	TYP	MAX	Unit
Operating Temperature	0	25	85	deg.C
VCC33	3.0	3.3	3.6	V
VIO	1.71	1.8	1.89	V

6.2 Power Consumption

Power Consumption	VCC33 = 3.3V(Unit:mA)	
	TX (2.4G 11B)	368
	RX (2.4G 11B)	251
	TX (2.4G 11G)	444.8
	RX (2.4G 11G)	251.2
	TX (2.4G 11N)	704
	RX (2.4G 11N)	251.2
	TX (2.4G 11AC)	680
	RX (2.4G 11AC)	256
	TX (2.4G 11AX)	660.8
	RX (2.4G 11AX)	254
	TX (5G 11G)	368

	RX (5G 11G)	188.8
	TX (5G 11N)	624
	RX (5G 11N)	193.6
	TX (5G 11AC)	652.8
	RX (5G 11AC)	203.2
	TX (5G 11AX)	648
	RX (5G 11AX)	209.6

6.3 Interface Circuit time series

6.3.1 Powerup sequence timing

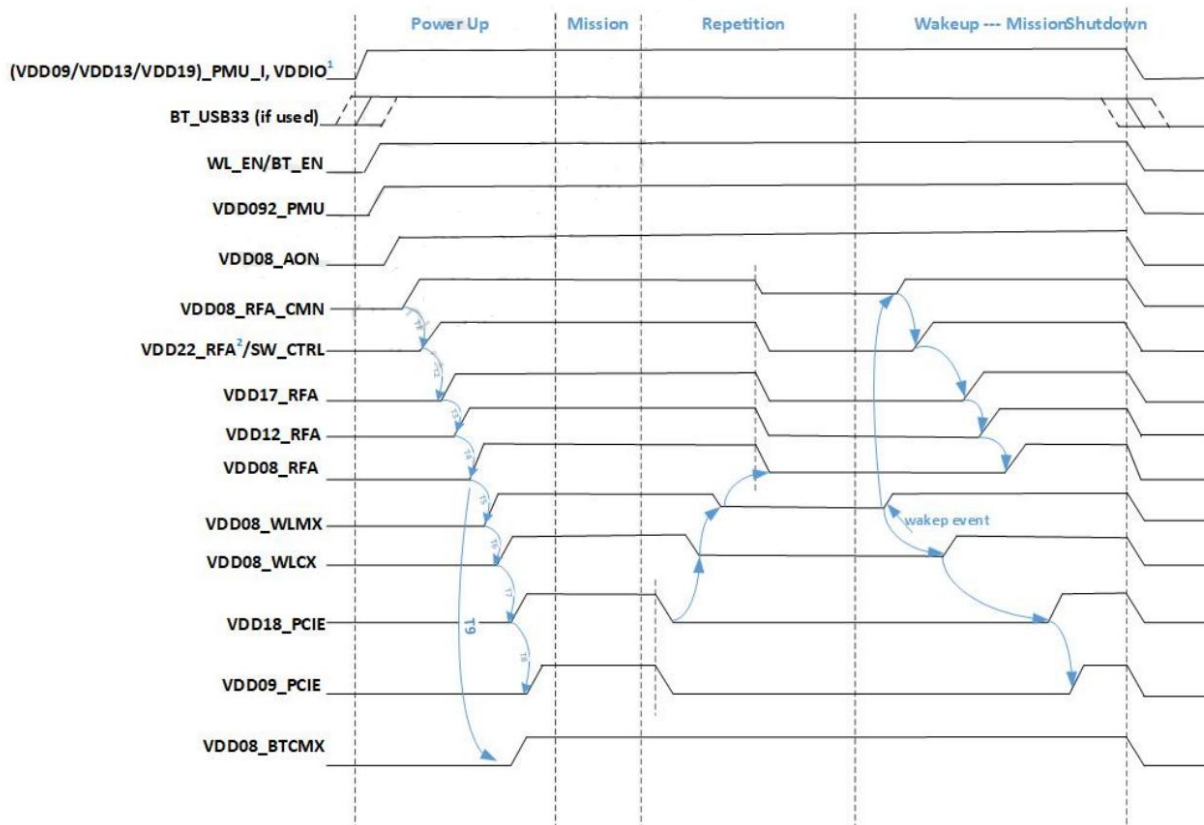

1. All input supplies must be ON and available before WLAN/BT_EN is asserted. There is no requirement on the order of input supply.
2. VDD22_RFA is used as internal PA supply and follows SW_CTRL. For design with external PA only, VDD22 pins need to be connected to the 1.9V input. Refer to reference schematic for details.

Power sequence timing parameters

Symbol	Description	Timing	Unit
T1	The delay time from RFACMN LDO to SW_CTRL = H	1.35	ms
T2	The delay time from SW_CTRL = H to enable RFA_VDD17	2	ms
T3	The delay time from turn on RFA_VDD17 to turn on RFA_VDD12	80	μs
T4	The delay time from turn on RFA_VDD12 to turn on RFA_VDD08	80	μs
T5	The delay time from turn on RFA_VDD08 to turn on both WL_MX	3.43	ms
T6	The delay time from turn on WL_MX to turn on WL_CX	1.205	ms
T7	The delay time from turn on WL_CX to turn on PCIE_VDD_18	1.205	ms
T8	The delay time from turn on PCIE_VDD_18 to turn on PCIE_VDD_95	1.13	ms
T9	The delay time from turn on RFA_VDD08 to turn on BT_CMX	4.33 ¹	ms

¹ Timing is 4.33 ms if WLAN is enabled and TCXO is used; timing is 4.98 ms if WLAN is enabled and XO is used; timing is 3.99 ms if only Bluetooth enabled and TCXO is used; timing is 4.64 ms if only Bluetooth enabled and XO is used.

6.3.2 UART interface

UART parameter	Value
Number of data bits	Eight
Parity bit	No parity
Stop bit	One stop bit
Flow control	RTS/CTS (hardware)
Flow off response	Two bytes maximum
Supported transport bit rates (bps) ¹	9.6 K, 19.2 K, 38.4 K, 57.6 K, 115.2 K, 125 K, 230.4 K, 250 K, 460.8 K, 500 K, 720 K, 921.6 K, 1 M, 1.6 M, 2 M, 3 M, 3.2 M, with an accuracy of +1.5/-2.5%

¹ UART maximum baud rate is 3.2 Mbps.

The HCI UART transmit timing is shown in the following figure and table.

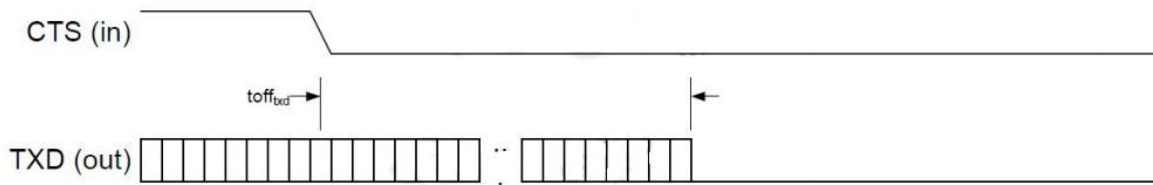

Figure 3-3 HCI UART transmit flow control timing

Table 3-11 HCI UART transmit flow control timing parameter

Parameter		Min	Typ	Max	Unit
toff _{bxd}	Delay from CTS to TXD stop	–	–	8	byte

The HCI UART receive timing is shown in the following figure and table.

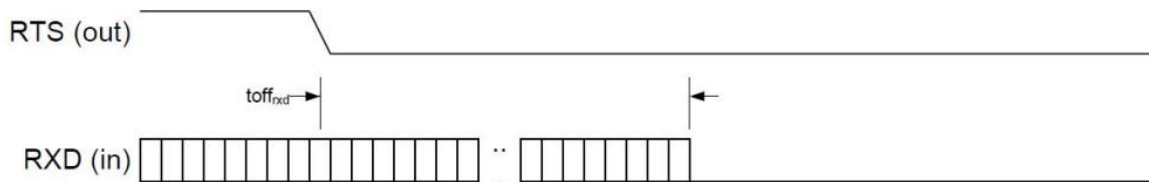

Figure 3-4 HCI UART receive flow control timing

Table 3-12 HCI UART receive flow control timing parameter

Parameter		Min	Typ	Max	Unit
toff _{rxd}	Delay from RTS to RXD stop	–	–	8	byte

6.3.3 PCM interface

Typical PCM interface audio latency

Packet type	Audio latency
HV3/EV3 $T_{eSCO} = 6, W_{eSCO} = 0$	4.4 ms
EV3 $T_{eSCO} = 6, W_{eSCO} = 2$	5.7 ms
EV3 $T_{eSCO} = 6, W_{eSCO} = 4$	6.9 ms

The PCM interface is configured to operate as master or slave. In each case, the PCM_IN pin is the data receive terminal (an input), and the PCM_OUT pin is the data transmit terminal (an output). The clock and sync pins function as inputs or outputs, depending on whether the QCA2066 PCM interface is configured as a master or slave:

- When the QCA2066 PCM interface is the **master**: PCM_CLK and PCM_SYNC are outputs from the QCA2066 to the PCM bus slave(s).
- When the QCA2066 PCM interface is the **slave**: PCM_CLK and PCM_SYNC are inputs to the QCA2066 device from the PCM bus master.

The following table lists the PCM interface specifications.

PCM interface specifications

Parameter	Comments	Min	Typ	Max	Units
Clock rate (slave)	Determined by the master	64	–	2,048	kHz
Clock rate (master)	$(32 \text{ MHz} * N/4,000)$, where N is an integer, $8 \leq N \leq 256$	64	–	2,048	kHz
Frame size		1	8	256	Bits
Slot size		1	13	16	Bits
Slot number	Number of slots that can be configured per frame	1	–	32	Slots/frame

Example timing diagrams and specifications for slave and master configurations are described in the following illustrations and tables.

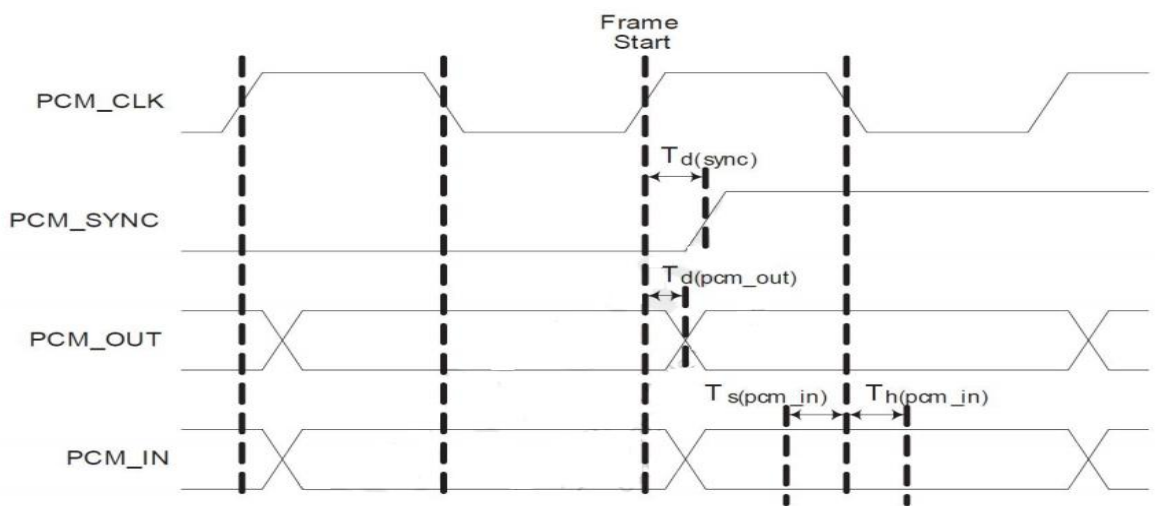

PCM interface timing diagram (slave)

PCM interface timing in slave mode

Symbol	Description	Min	Typ	Max	Units
F_{pcm_clk}	PCM_CLK frequency	64	–	2048	kHz
$T_{s(pcm_sync)}$	Setup time PCM_SYNC to PCM_CLK fall	0	–	–	ns
$T_{h(pcm_sync)}$	Hold time PCM_CLK fall to PCM_SYNC fall	150	–	–	ns
$T_{d(pcm_out)}$	Delay from PCM_CLK rise to PCM_OUT	0	–	150	ns
$T_{s(pcm_in)}$	Setup time PCM_IN to PCM_CLK fall	0	–	–	ns
$T_{h(pcm_in)}$	Hold time PCM_IN after PCM_CLK fall	150	–	–	ns

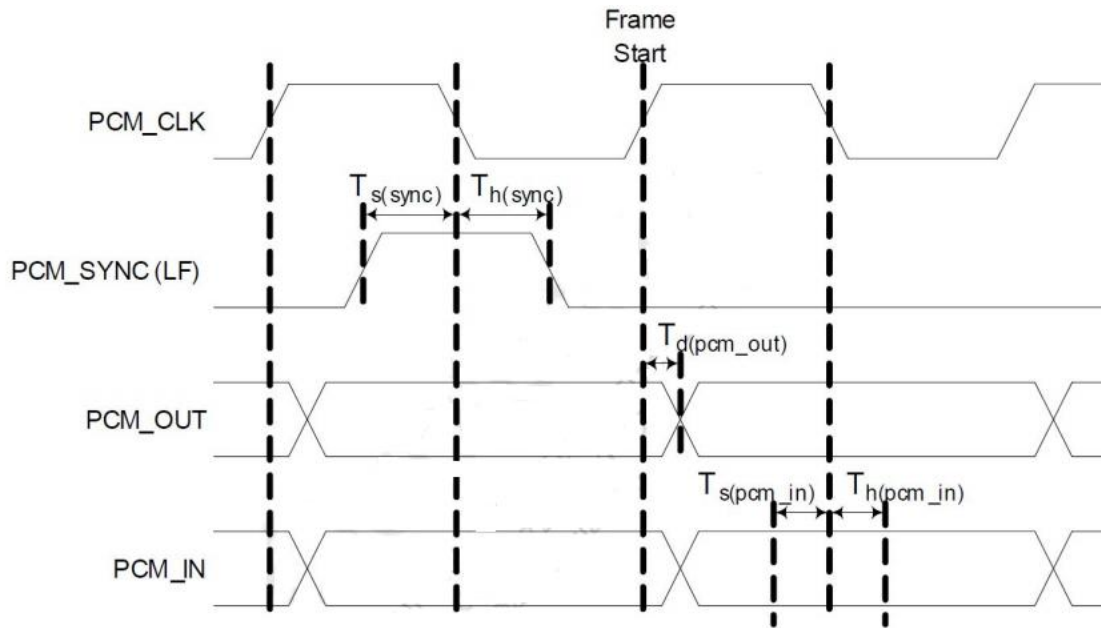

Figure 3-6 PCM interface timing diagram (master)

Table 3-16 PCM interface timing in master mode

Symbol	Description	Min	Typ	Max	Units
$F_{\text{pcm_clk}}$	PCM_CLK frequency	64	–	2048	kHz
$T_d(\text{sync})$	Delay from PCM_CLK rise to long SYNC	-10	–	50	ns
$T_d(\text{pcm_out})$	Delay from PCM_CLK rise to PCM_OUT	-10	–	50	ns
$T_s(\text{pcm_in})$	Setup time PCM_IN to PCM_CLK fall	50	–	–	ns
$T_h(\text{pcm_in})$	Hold time PCM_IN after PCM_CLK fall	150	–	–	ns

7. Size reference

7.1 Module Picture

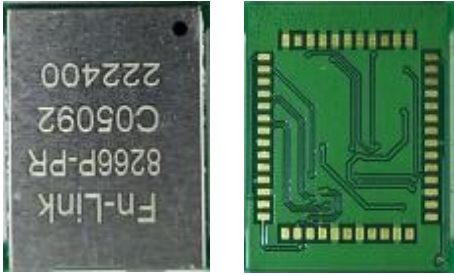
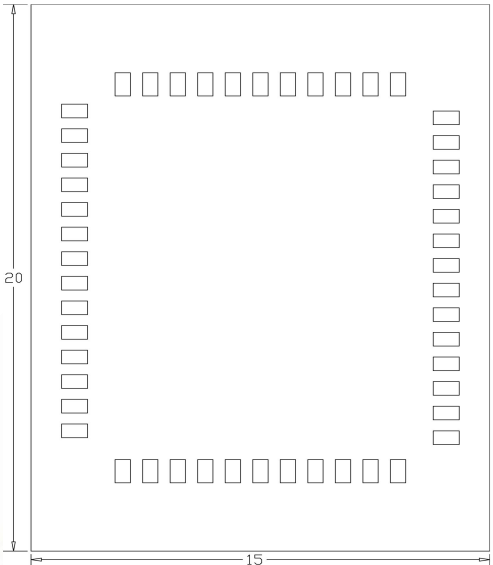
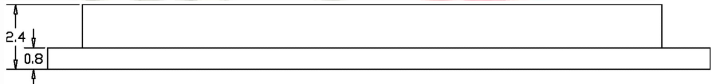
<p>L x W : 15 x 20 (+0.3/-0.1) mm</p> <p>Pin1 mark</p> 	
<p>H: 2.4 (±0.2) mm</p>	
<p>Weight</p>	<p>0.8g</p>

7.2 Marking Description

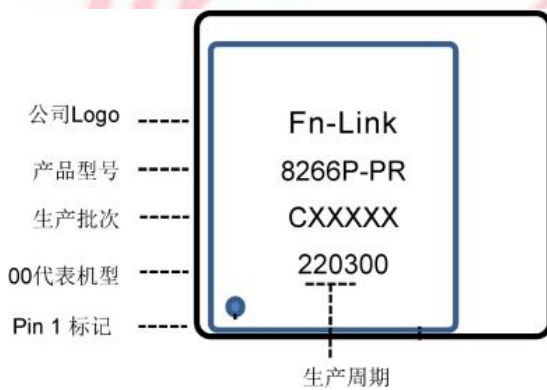

7.3 Physical Dimensions

<TOP View>

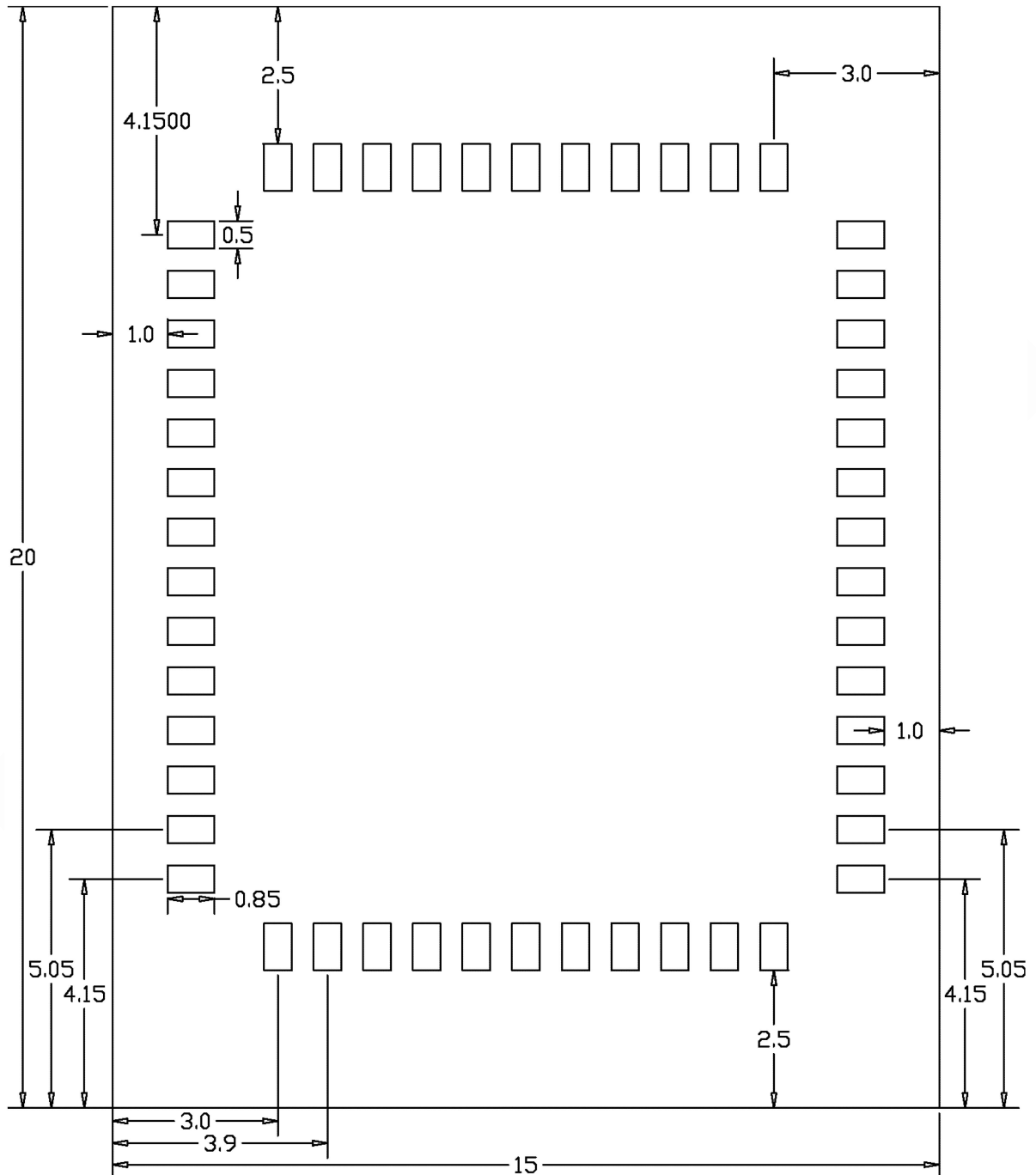

Notes: Recommended PCB footprint flow as above diagram dimensions.

8. The Key Material List

Item	Part Name	Description	Manufacturer
1	Inductor	0805,2.2UH,±20%,Irms=2.0A,Isat=2.45A	Sunlord,Ceaiya,cenker,TAIYO,INP AQ,GK PRECISION
2	Switch	3T/MXD8730L QFN-8	Maxscend, Skyworks,Qware
3	Diplexer	Diplexer,1608,DP1608-R2460NNQ2B/LF (AC X)	Glead, Walsin, ACX, Murata, MAG.LAYERS,TDK,Ftrgroup
4	Crystal	2016,76.8MHZ,±10PPM,9.9PF,-40~85°	JWT,ECEC, TKD, Hosonic, TXC
5	Chipset	QCA-2066-0-NSP288-TR-02-1	Qualcomm
6	PCB	8266P-PR,green,6layer,HDI,FR4,AU,15X20X0.8mm	Sunlord,SL-PCB,GDKX,Truly,Brain power
7	Switch	0.5 to 7.125GHz SPDT Switch,MXD8723E,QFN6,1X1-0.45mm	Maxscend, Skyworks, Qware
8	DCDC	3A/1MHz	RYCHIP,Natlinear,ETA,MPS
9	Shielding	8266P-PR ,shielding ,14X19X1.6mm T=0.2	信太,精力通,卓益

9. Reference Design

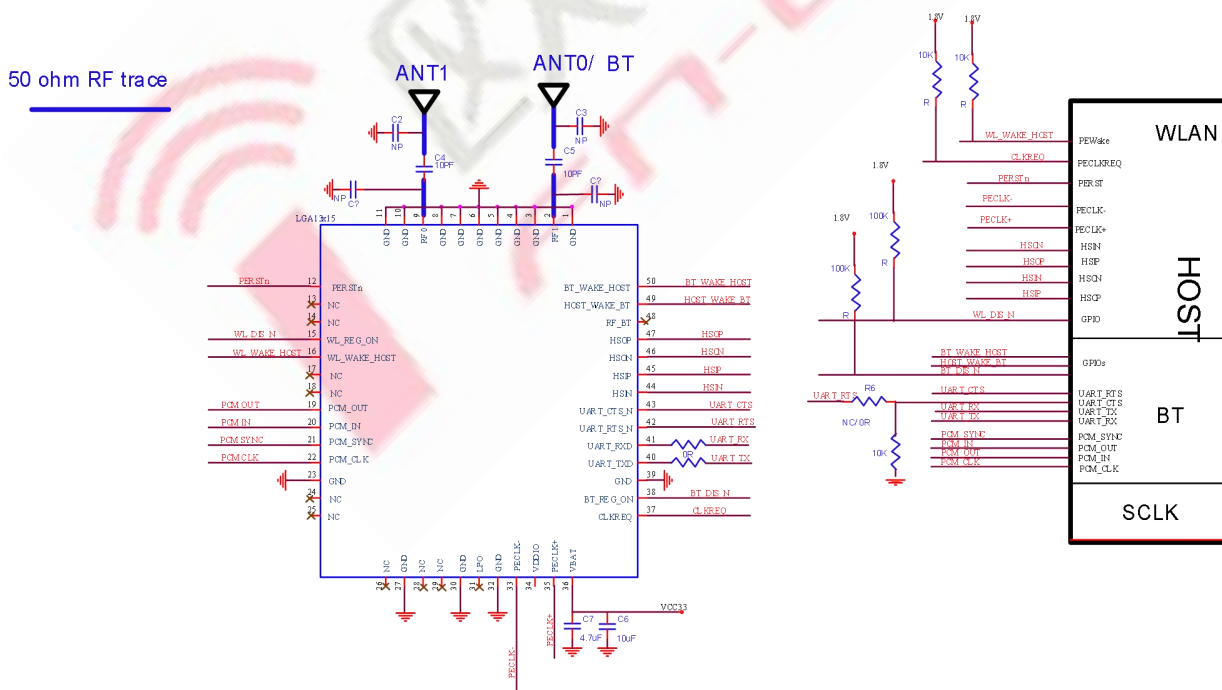

Note:

RF_BT no used keep NC;

PCIe trace please do impedance control;

10. Recommended Reflow Profile

Referred to IPC/JEDEC standard.

Peak Temperature: 260 ± 5 °C

5Time within 5° C of peak temperature: ≥ 10 s

Number of Times: 2 times

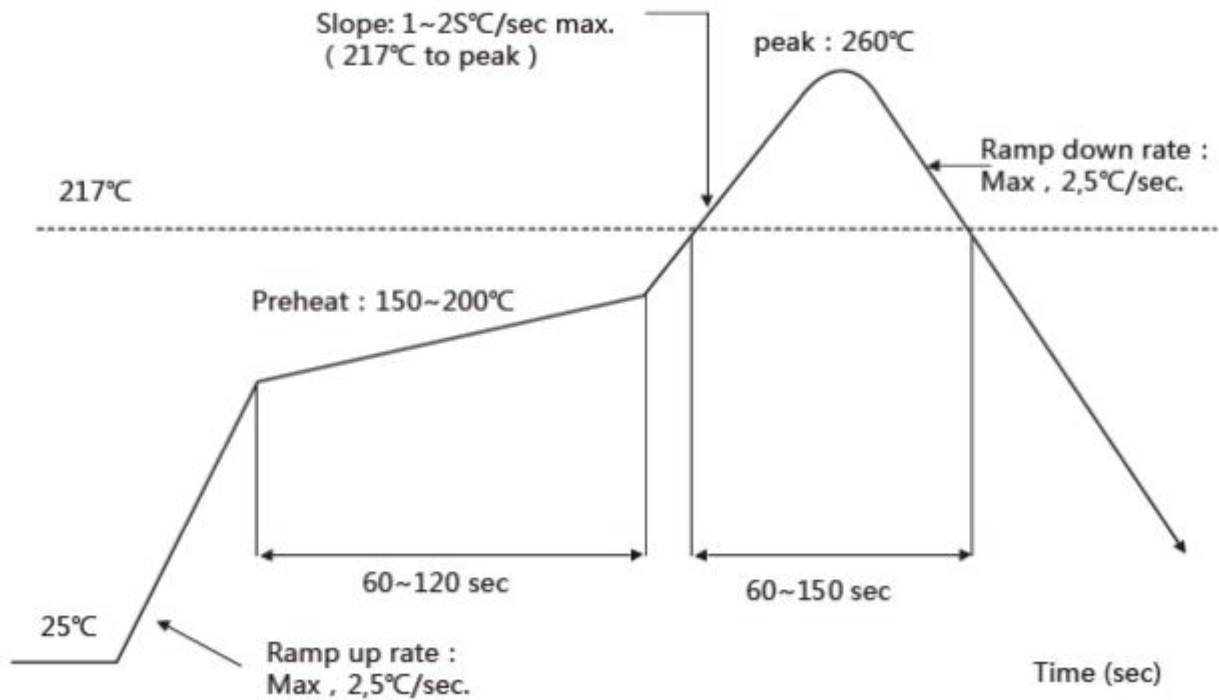

11. RoHS compliance

All hardware components are fully compliant with EU RoHS directive

12. Package

12.1 Reel

A roll of 800pcs

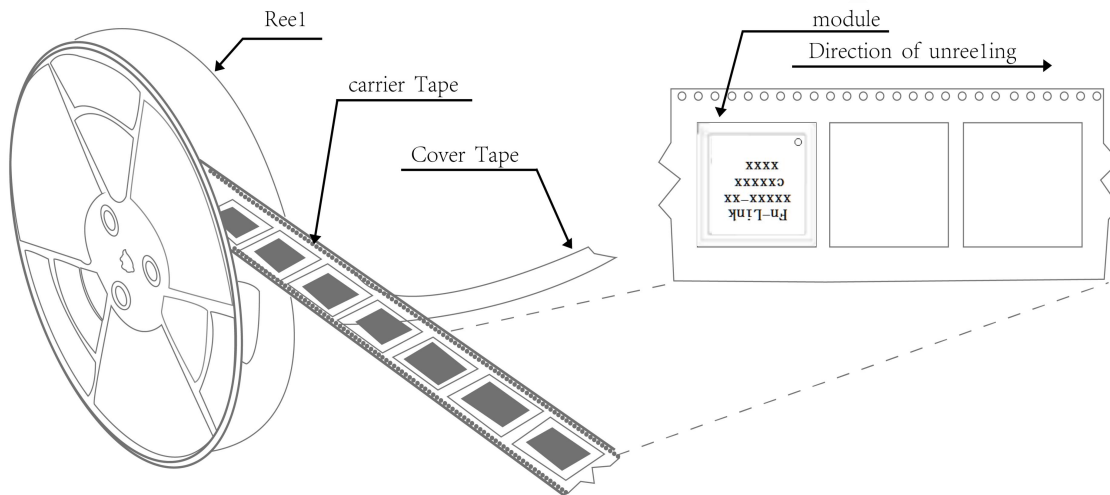

12.2 Carrier Tape Detail

NA

12.3 Packaging Detail

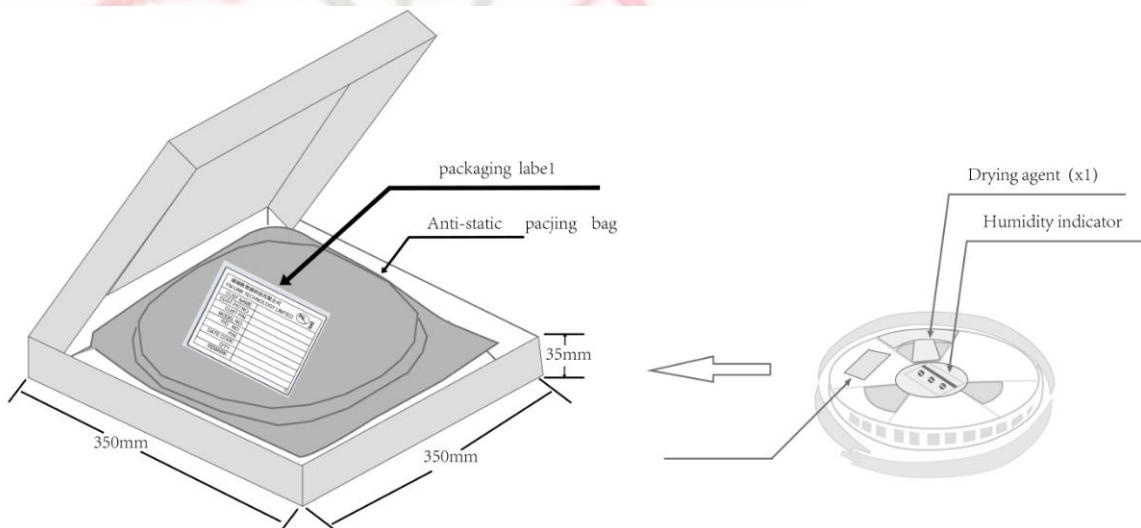

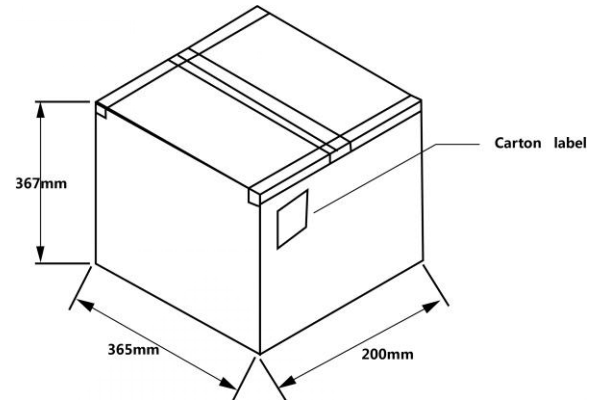
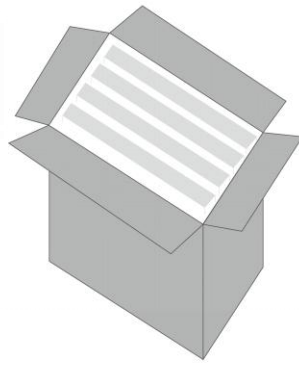

13. Moisture sensitivity

The Modules is a Moisture Sensitive Device level 3, in according with standard IPC/JEDEC J-STD-020, take care

all the relatives requirements for using this kind of components.

Moreover, the customer has to take care of the following conditions:

- a) Calculated shelf life in sealed bag: 12 months at <math><40^{\circ}\text{C}</math> and <math><90\%</math> relative humidity (RH)
- b) Environmental condition during the production: 30°C / 60% RH according to IPC/JEDEC J-STD-033A paragraph 5
- c) The maximum time between the opening of the sealed bag and the reflow process must be 168 hours if condition
- b) "IPC/JEDEC J-STD-033A paragraph 5.2" is respected
- d) Baking is required if conditions b) or c) are not respected
- e) Baking is required if the humidity indicator inside the bag indicates 10% RH or more