

Habanero system on module (SOM) is based on an IPQ4019/IPQ4029 SoC from Qualcomm, which incorporates a powerful quad-core ARM Cortex A7 processor with NEON and FPU. It is ideal for resource demanding applications including routers, gateways and access points. Habanero comes with a high-power, dual-band concurrent radio supporting 802.11ac Wave2 technology (2x2 MiMo). QCA8075C PHY gives support to 5 x Gigabit Ethernet ports. It also has 1 x USB3.0 and 1 x USB2.0 ports and supports other miscellaneous interfaces, which can be configured as general-purpose I/O pins. Hardware based NAT engine and security features like crypto engine, secure boot make it ideal for high-end, fast and secure networking applications. Habanero comes in commercial and industrial temperature versions. Commercial temperature range: 0-65°C, industrial temperature range: -40-85°C.

Quick specs

- Wi-Fi 5 (802.11a/n/ac Wave2) 5GHz with 2x2 MU-MiMo, 866.7Mbps data-rate
- Wi-Fi 5 (802.11b/g/n/ac) 2.4GHz, 400Mbps data-rate
- MIPI DBI v2.0 type B interface
- CPU - IPQ4019/IPQ4029 (716.8MHz)
- OpenWRT Linux flash image
- 24-25 dBm per chain RF output power
- Size - 45 by 49 mm
- Available interfaces – 46 x GPIO, 1 x PCIe 2.0, 1 x USB3.0, 1 x USB2.0, 2 x UART, 1 x SPI, 2 x I2C, 4 x PWM, 1 x JTAG, 1 x I2S/TDM, 5 x 1000/100/10 ethernets, 1 x RGMII, 1 x SDIO3.0/eMMC and parallels for NAND flash memory and LCD controller

1. Features

1.1. Features

TABLE 1-1. 8DEV6000 HABANERO FEATURES

Feature list		8DEV6000 Habanero	
Integrated core	Core type	ARM Cortex-A7 IPQ4019/IPQ4029	
	Core clock frequency	716.8MHz	
	Cache	256KB L2	
Memory	DRAM	DDR3L 512MB (up to 1GB)	
	NOR FLASH	32MB	
	NAND FLASH (external)	1GB(tested)	
WIFI	IEEE 802.11 b/g/n/ac 2x2 MU-MIMO 2.4GHz 20/40 MHz 256 QAM	2402-2482MHz 25dBm	
	IEEE 802.11 b/g/n/ac 2x2 MU-MIMO 5GHz 20/40/80 MHz 256 QAM	4920-5920MHz 24dBm	
RF pin	RF signal is fed to 2 external module pins	2	
Display	LCD controller	1	
	MIPI DBI v2.0 type B interface (Intel 8080 9bit parallel)	1	
Peripherals	PCIe	PCIe 2.0	1
	USB	USB 3.0	1
		USB 2.0	1
	UART	Universal asynchronous receiver transmitter serial ports	2
	SPI	Serial peripheral interface port	1
	I2C	Inter-integrated circuit interfaces for peripheral devices	2
	GPIO	IN/OUT/INT	46
	PWM	Audio Pulse Width Modulation interface	4
	JTAG	Debug interface	1
	I2S/TDM	Multichannel interfaces for digital audio support	1
	Parallel	For parallel NAND flash memory	1
		For parallel LCD controller	1
	Ethernet	Copper 10BASE-Te/100BASE-TX/1000BASE-T	5
		Fiber 100BASE-FX/1000BASE-X	1
	RGMI	Reduced gigabit media independent interface	1
Reset	Reset button controlled via voltage monitor	1	
SDIO3.0/eMMC	Secure Digital Input Output / Embedded Multi Media Card	1	

2. Block diagram

The following figure provides a basic overview of the 8DEV6000 Habanero module.

FIGURE 2-1. 8DEV6000 HABANERO MODULE BLOCK DIAGRAM

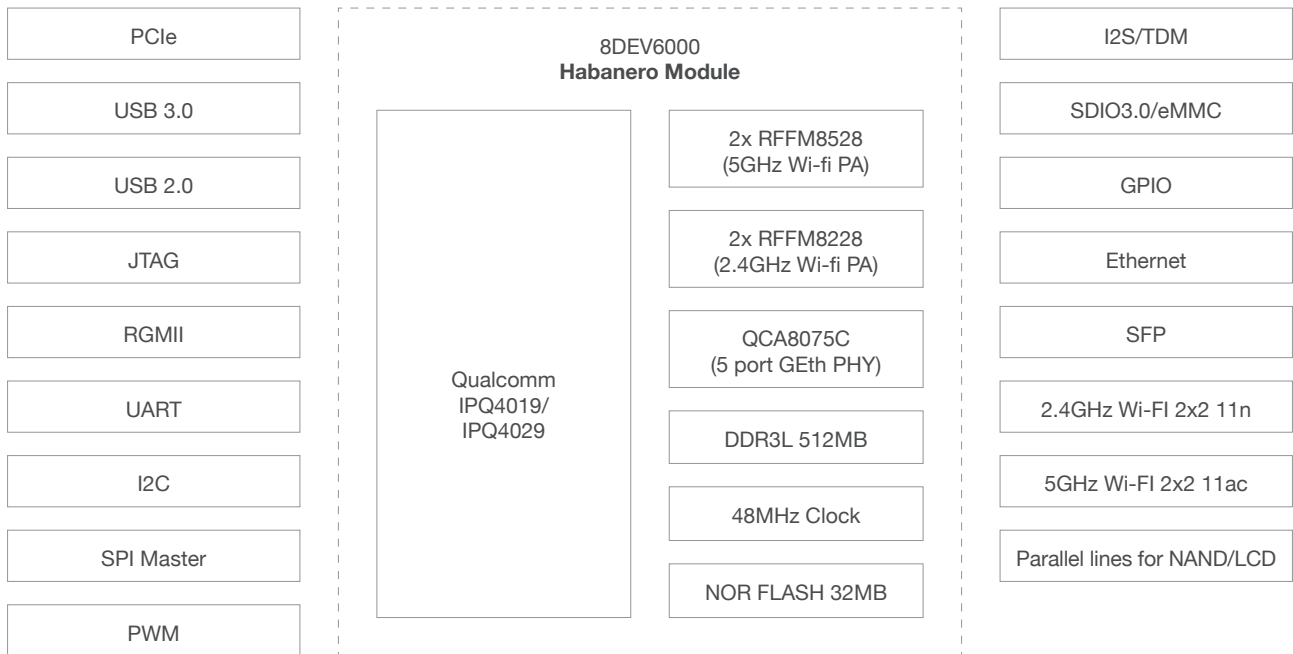

3. Mechanical characteristics

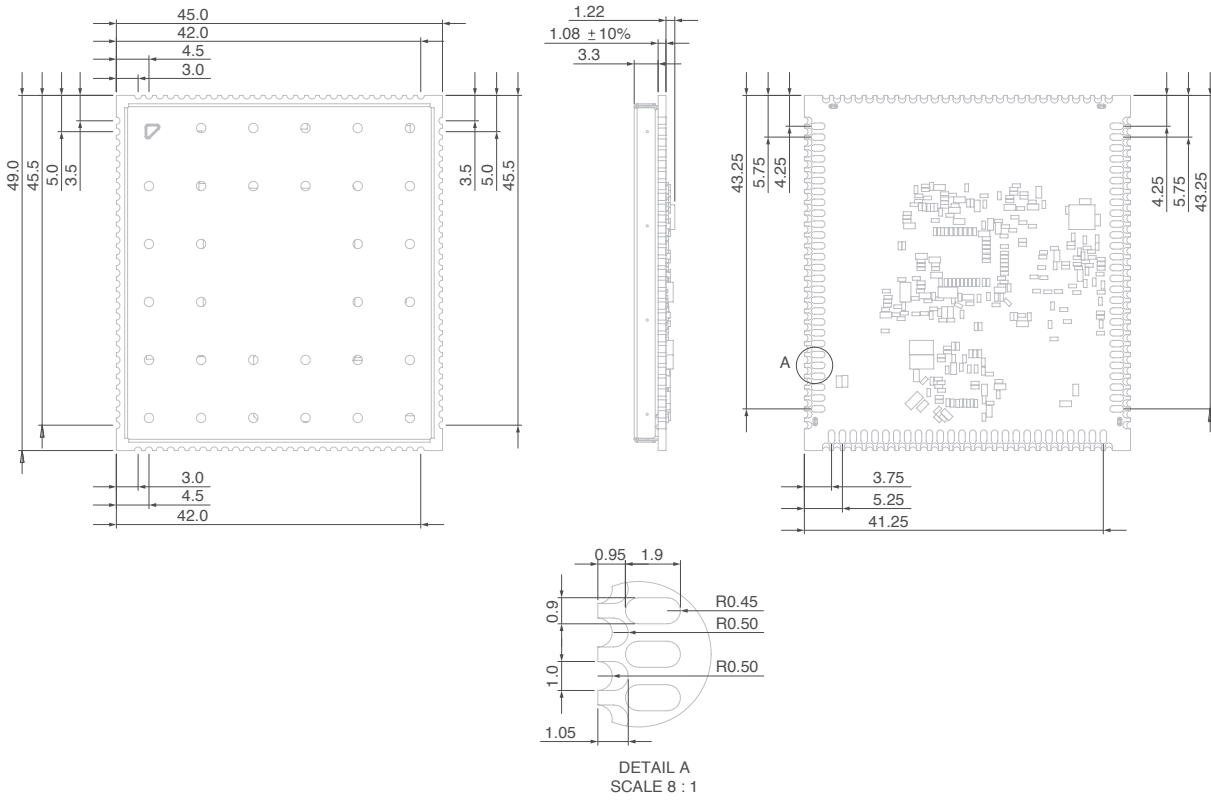

PCB footprint

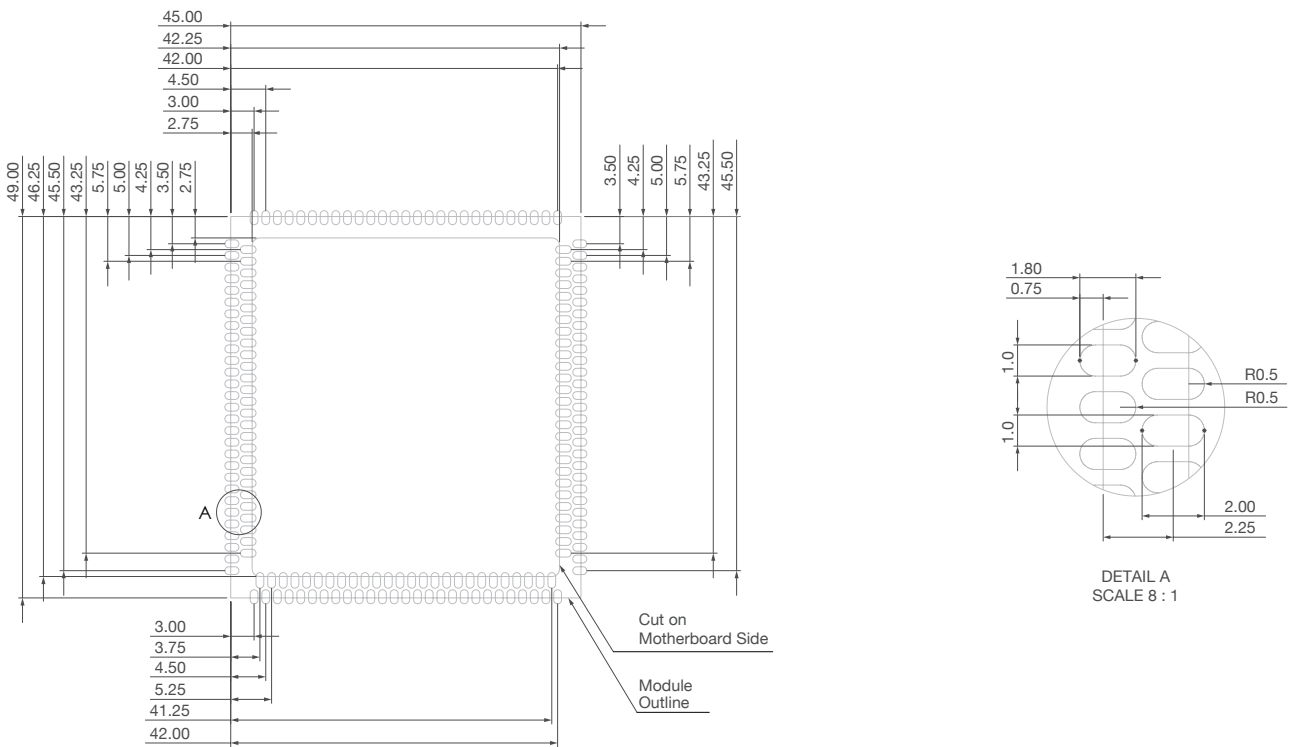

4. Development board

4.1 DVK dimensions

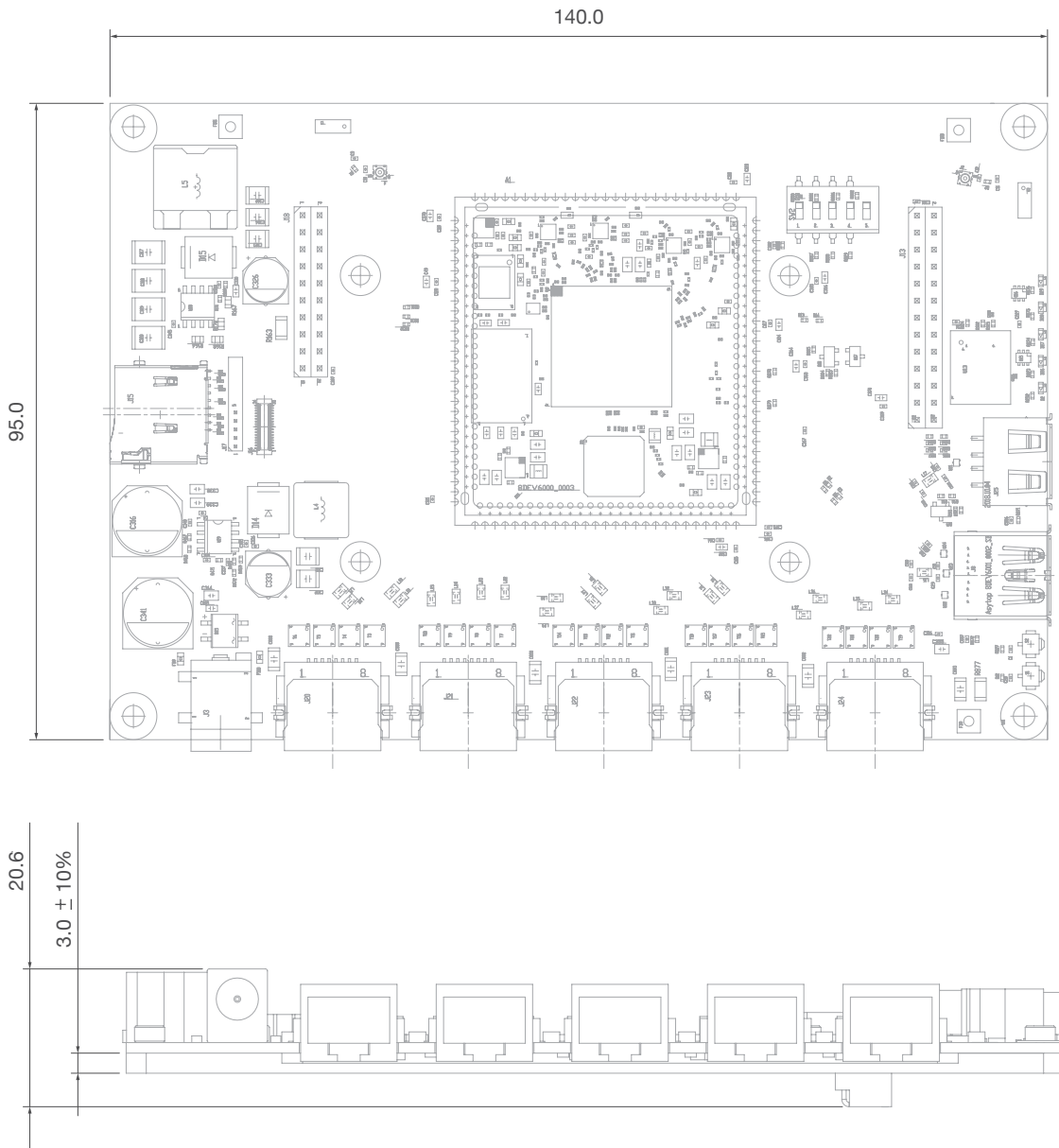

4.2 DVK interfaces

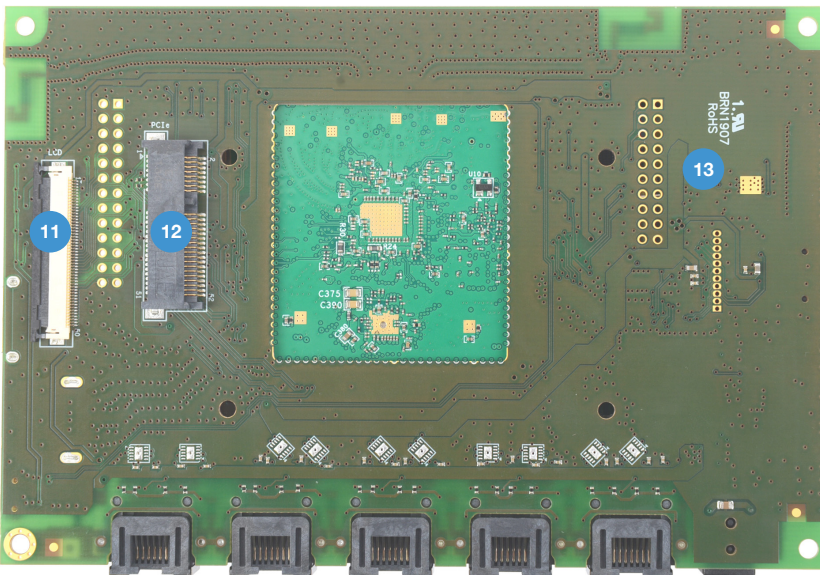
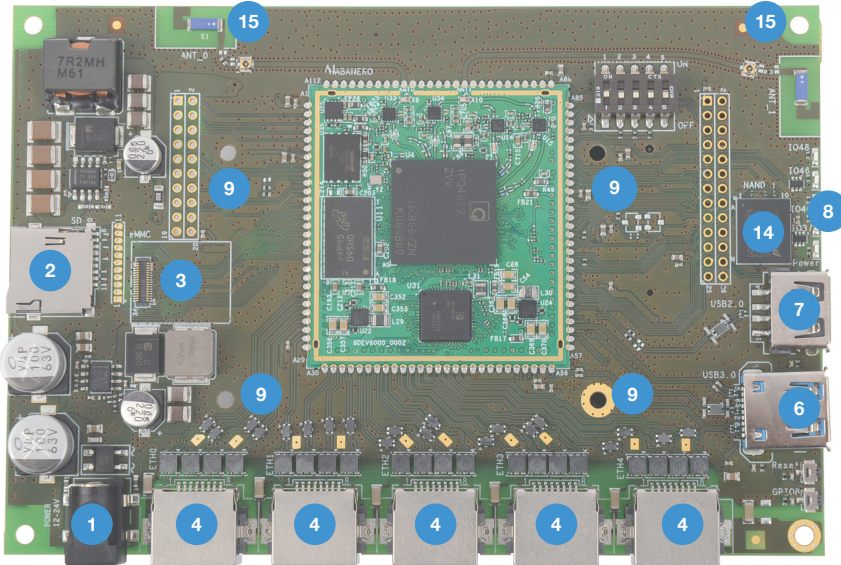

- | | |
|---------------------------|-------------------------|
| 1. Power 12V-24V | 9. Heatsink screws |
| 2. SD card socket | 10. Habanero module |
| 3. eMMC connector | 11. FPC connector |
| 4. Ethernet port | 12. PCIe connector |
| 5. Buttons (Reset, GPIO8) | 13. Heatsink |
| 6. USB 3.0 (5V 1A) | 14. External NAND place |
| 7. USB 2.0 (5V 1A) | 15. Dual-band antennas |
| 8. LEDs | |

4.3 LEDs

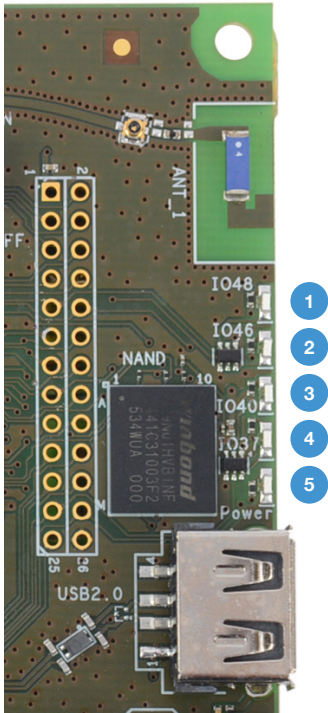

LED number	Description
1	GPIO48
2	GPIO46
3	GPIO40
4	GPIO37
5	Power

4.4 BOOTSTRAP switch

	1	2	3	4	5
	JTAG_EN	USB_BOOT	GPIO14	GPIO51	Not connected
ON	GPIO0~GPIO5 are used as JTAG interface.	Force boot from USB	1	1	-
OFF	GPIO0~GPIO5 are normal GPIOs.	Normal boot	0	0	-

GPIO14 AND GPIO51 CONFIGURATION

GPIO51	GPIO14	Function description
0	0	Boot interface is SPI
0	1	Boot interface is eMMC
1	0	Boot interface is QPIC
1	1	Boot from USB

4.5 DVK header pinout

J13

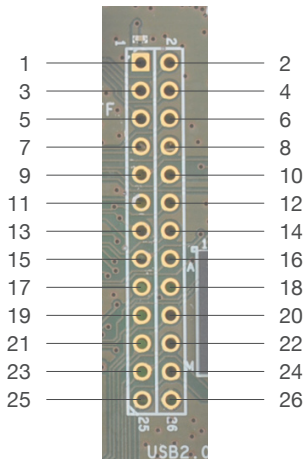

Header pin	GPIO	Header pin	GPIO	Header pin	GPIO
1	3.3V	10	GPIO61	19	GPIO45
2	GPIO2	11	GPIO51	20	GPIO41
3	GPIO0	12	GPIO52	21	GPIO42
4	GPIO1	13	GPIO50	22	GPIO39
5	GPIO5	14	GPIO47	23	GPIO40
6	GPIO3	15	GPIO48	24	GPIO37
7	GPIO7	16	GPIO49	25	GPIO36
8	GPIO54	17	GPIO43	26	GND
9	GPIO46	18	GPIO44	-	-

J17

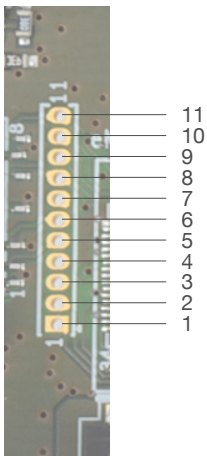

Header pin	GPIO	Header pin	GPIO
1	GPIO30	7	GPIO25
2	GPIO29	8	GPIO24
3	GPIO23	9	GPIO32
4	GPIO27	10	GPIO31
5	GPIO26	11	GPIO22
6	GPIO28	-	-

J18

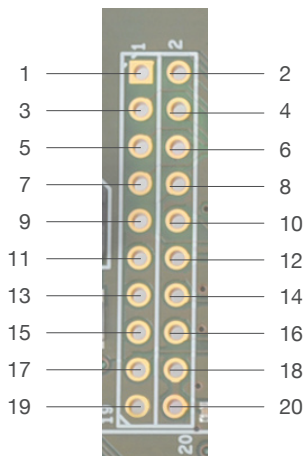

Header pin	GPIO	Header pin	GPIO	Header pin	GPIO
1	GPIO8	8	3.3V	15	CHIP_RST_OUT
2	GND	9	GPIO18	16	GPIO34
3	GPIO11	10	GPIO20	17	5V
4	UART_RXD	11	GPIO21	18	3.3V
5	GPIO10	12	GPIO33	19	GND
6	UART_TXD	13	GND	20	3.3V
7	GPIO09	14	GPIO35	-	-

4.6 DVK heatsink

