

Qualcomm

# Qualcomm® QCA4531

## Wi-Fi SoC

**QCA4531 is a low-cost, high performance, Linux connectivity hub for the Internet of Things (IoT).**

The QCA4531 is a two stream (2x2) 802.11b/g/n single-band programmable Wi-Fi System-on-Chip (SoC) for the IoT. This low-cost turnkey solution combines high-performance connectivity capabilities with a user-programmable Linux OpenWrt environment and is designed to serve either as a feature-rich IoT node or as a hub to support an IoT ecosystem.

The QCA4531 is a single-chip access point SoC designed to deliver a high-performance 2x2 802.11b/g/n solution, as well as a powerful MIPS 24Kc CPU core that operates at up to a 650MHz clock rate. This system runs open source Linux and the OpenWrt networking stack, to help with ease of development.

The QCA4531 includes a communications stack, including HTTP, IPv4v6, TCP, SSL, DHCP, ICMP, IGMP, and DNS. It is designed to operate as an IoT access point, supporting up to 16 simultaneous devices, and is power optimized to allow appliances to meet international standards for energy efficiency.

To address fragmentation in the IoT, the QCA4531 supports multiple application layer interoperability standards, allowing products to connect across different brands and platforms. The QCA4531 is ideal for IoT hubs that bridge from other IoT connectivity technologies like Bluetooth, 802.15.4 (ZigBee/Thread) and Z-Wave to the home Wi-Fi network. It contains interfaces that allow attachment of Bluetooth/802.15.4/Z-Wave radios, plus the Linux environment supports the development of bridging software.

### Highlights

#### Operates as a versatile, feature-rich IoT node, access point, gateway or hub

Multi-protocol bridging and communication brings together multiple wireless mediums and bridges between different ecosystems.



#### Single chip solution with extended range and reliability

Incorporates 802.11n 2x2 single-band Wi-Fi technology and extended wireless range, providing greater coverage, quality of service and reliability of connectivity.



#### Optimized power and energy efficiency for high performance IoT gateways

Integrates a powerful 650MHz MIPS CPU for embedded applications, plus a 1+4 Fast Ethernet switch along with other expansive interfaces for IoT devices.



#### Open source OS and tools to simplify software development

Embeds OpenWrt, Linux OS and open source Wi-Fi drivers for simplifying software development.



Qualcomm

QCA4531

## QCA4531 Target IoT Applications

- Energy Management
- Smart Home
- Wi-Fi Repeater
- Smart Appliances
- Residential Lighting
- IoT Gateway

## Features

- 802.11n 2x2 improves range and quality of service
- MIPS 24Kc processor operating at up to 650MHz clock rate
- Advanced power management with dynamic clock switching for ultra-low power modes
- DDR2 NAND SPI flash memory manager
- I<sup>2</sup>C for connecting to digital sensors and Apple HomeKit MFi chip
- 12 customizable GPIOs
- Commercial & industrial temperature options
- OpenWrt QDSK and open source ATH9K drivers
- Low cost system BOM including:
  - Integrated LNA and +20 dBm PA
  - QFN package and 4-layer PCB design
  - 3.3V external power source
- External 16-bit DDR1, operating at up to 200MHz, DDR2 operating at up to 300MHz (600 M transfers/sec)
- Software support for Apple HomeKit, Google Weave, Open Connectivity Foundation and AllJoyn from the AllSeen Alliance
- Complete AllJoyn integration client and services implementation

## Ordering Information

Product	Part Number
QCA4531 (C-Temp)	QCA4531-BL3A
QCA4531 (I-Temp)	QCA4531-BL3B

To learn more visit: [qualcomm.com](http://qualcomm.com)

## QCA4531 Block Diagram

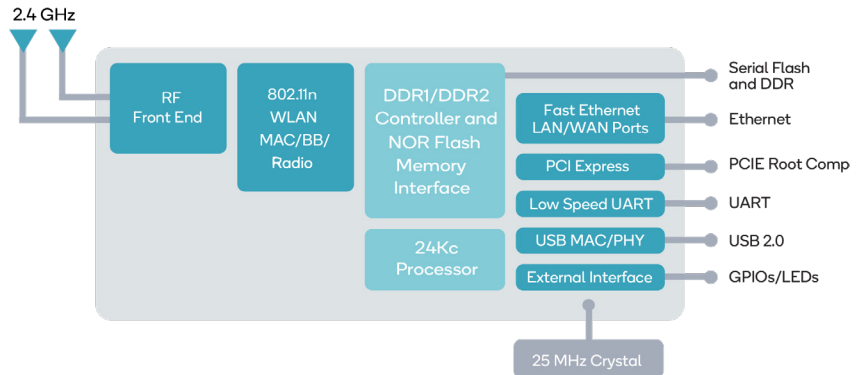

## QCA4531 SoC and Module Specifications

<b>Package Type</b>	12 x 12mm QFN Dual-Row 156-pin halogen-free, RoHS compliant
<b>Module Size</b>	44.3 x 33.5 x 6.2mm, 4 layer PCB (including PCB antenna & 2x 1-PEX connectors)
<b>WLAN Technology</b>	802.11b/g/n
<b>Antennas</b>	2x 2.4GHz outputs
<b>Interfaces</b>	1x DDR, PCIE, UART, I <sup>2</sup> C, USB 2.0 Host 12x GPIOs, JTAG 1+4 (5-port) Fast Ethernet switch
<b>Frequency Band</b>	2.4GHz
<b>Channel Bandwidth</b>	20 or 40MHz
<b>Power Source</b>	3.3V nominal
<b>Throughput</b>	2x2 802.11n - 190Mbps (TCP/IP)
<b>Default Memory</b>	64MB DDR; 1GB NAND SPI flash 1x 4MB NOR flash
<b>Operating System</b>	OpenWrt, Embedded Linux
<b>Operating Temperature</b>	Commercial: 0° to +70°C Industrial: -40° to +85°C