

Lima has 802.11N 2x2 radio supporting up to 300 Mbps data-rate and comes in two versions: commercial or industrial temperature

Lima is a QCA 4531 chipset based module with a 650 MHz CPU and 802.11N 2x2 (MIMO) radio. Module is available in two temperature ranges: commercial* (Lima) and industrial** (Lima-I).

Lima is a surface mountable, dual-sided, Wi-Fi enabled Linux module for the (IoE) internet of everything applications.

Faster CPU, 300 Mbps data-rate, low power consumption, larger 32 MB flash memory and a development kit with more interfaces (e.g. PCIe) are the key differentiators from Carambola 2 module.

OpenWRT linux distribution source code is available on GitHub <https://github.com/8devices> and is supported by our growing community on <http://www.8devices.com/community> forum.

*Commercial temperature range: 0 - 65° C

**Industrial temperature range: -40 - 85° C

Quick specs

- 802.11 b/g/n, 2.4 GHz, 2x2 MIMO, 300 Mbps data rate, 21 dB per chain output power
- U.FL connectors or external pin for external antenna
- 32 MB FLASH, 64 MB DDR2 RAM
- Linux friendly , OpenWRT flash image and source code are available for download on www.8devices.com/wiki_lima
- CPU – QCA 4531, 650 MHz clock speed
- Small form factor (25 by 35 mm)
- Surface mountable, dual-side design
- Industrial and commercial temperature range models
- Available interfaces - USB 2.0 host, 2 x Ethernet, UART, PCIe, GPIO, JTAG

Module dimensions

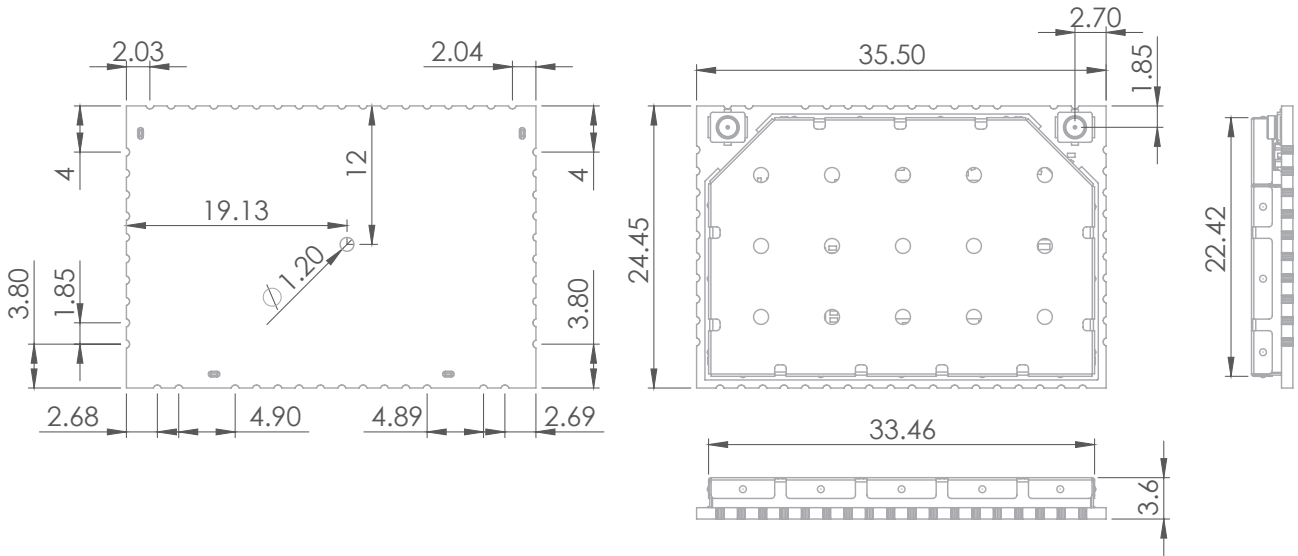

Block diagram

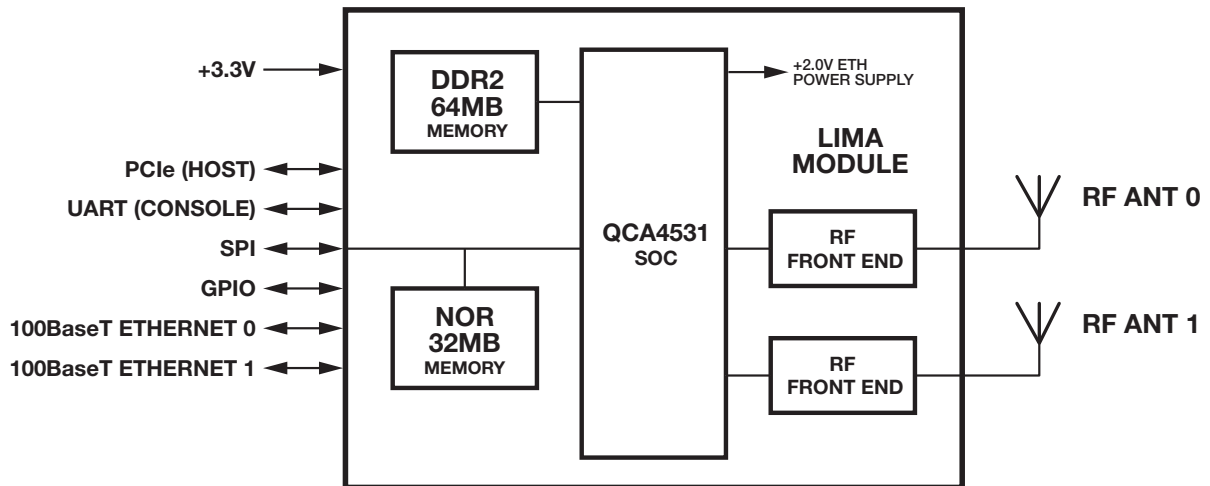

Development kit

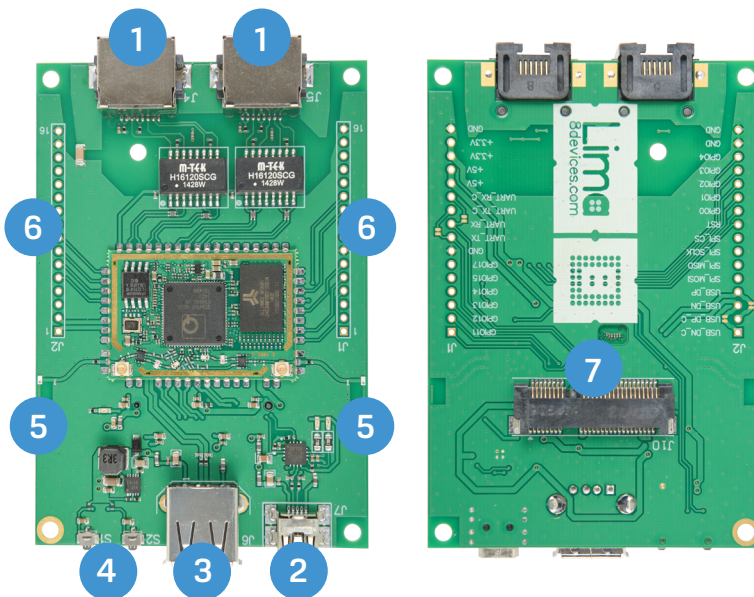

- 1 - 2 x 100 Base-T Ethernet ports
- 2 - Mini USB Type-A socket (console + power)
- 3 - USB Type-A socket
- 4 - Buttons: S1 - programmable (GPIO connected), S2 - reset
- 5 - Two integrated antennas
- 6 - 2.45 mm pitch connector holes
- 7 - MINI PCIe socket

Module pinout

