

IC REPORT

(Bluetooth)

Applicant: 8Devices

Address of Applicant: Gedimino 47, Kaunas, LT-44242, Lithuania

Equipment Under Test (EUT)

Product Name: Komikan

Model No.: Komikan

Canada IC: 11468A-KOM

Applicable standards: RSS-Gen Issue 5, March 2019 Amendment 1
RSS-247 Issue 2, February 2017

Date of sample receipt: 24 Mar., 2020

Date of Test: 24 Mar., to 06 May, 2020

Date of report issued: 01 Jun., 2020

Test Result: PASS *

* In the configuration tested, the EUT complied with the standards specified above.

Authorized Signature:



Bruce Zhang
Laboratory Manager

This report details the results of the testing carried out on one sample. The results contained in this test report do not relate to other samples of the same product and does not permit the use of the CCIS product certification mark. The manufacturer should ensure that all products in series production are in conformity with the product sample detailed in this report.

This report may only be reproduced and distributed in full. If the product in this report is used in any configuration other than that detailed in the report, the manufacturer must ensure the new system complies with all relevant standards.

This document cannot be reproduced except in full, without prior written approval of the Company. Any unauthorized alteration, forgery or falsification of the content or appearance of this document is unlawful and offenders may be prosecuted to the fullest extent of the law. Unless otherwise stated the results shown in this test report refer only to the sample(s) tested and such sample(s) are retained for 90 days only.

2 Version

Version No.	Date	Description
00	07 May, 2020	Original
01	01 Jun., 2020	Added 99% OBW data on 6.3 Occupy Bandwidth

Tested by: Mike.ou
Test Engineer

Date: 01 Jun., 2020

Reviewed by: Winner Zhang
Project Engineer

Date: 01 Jun., 2020

3 Contents

	Page
1 COVER PAGE	1
2 VERSION	2
3 CONTENTS	3
4 TEST SUMMARY	4
5 GENERAL INFORMATION	5
5.1 CLIENT INFORMATION.....	5
5.2 GENERAL DESCRIPTION OF E.U.T.	5
5.3 TEST ENVIRONMENT AND TEST MODE	6
5.4 DESCRIPTION OF SUPPORT UNITS	6
5.5 MEASUREMENT UNCERTAINTY.....	6
5.6 ADDITIONS TO, DEVIATIONS, OR EXCLUSIONS FROM THE METHOD	6
5.7 LABORATORY FACILITY.....	7
5.8 LABORATORY LOCATION.....	7
5.9 TEST INSTRUMENTS LIST	8
6 TEST RESULTS AND MEASUREMENT DATA	9
6.1 CONDUCTED EMISSIONS	9
6.2 CONDUCTED OUTPUT POWER	12
6.3 OCCUPY BANDWIDTH	16
6.4 CARRIER FREQUENCIES SEPARATION	21
6.5 HOPPING CHANNEL NUMBER	25
6.6 DWELL TIME	27
6.7 PSEUDORANDOM FREQUENCY HOPPING SEQUENCE.....	30
6.8 BAND EDGE.....	31
6.8.1 Conducted Emission Method	31
6.8.2 Radiated Emission Method	35
6.9 SPURIOUS EMISSION.....	72
6.9.1 Conducted Emission Method	72
6.9.2 Radiated Emission Method	75
7 TEST SETUP PHOTO	82
8 EUT CONSTRUCTIONAL DETAILS	85

4 Test Summary

Test Items	Section	Result
AC Power Line Conducted Emission	RSS-GEN Section 8.8	Pass
Conducted Peak Output Power	RSS-247 Section 5.4(b)	Pass
Occupied Bandwidth	RSS-247 Section 5.1(a)	Pass
Carrier Frequencies Separation	RSS-247 Section 5.1(b)	Pass
Hopping Channel Number	RSS-247 Section 5.1(d)	Pass
Dwell Time	RSS-247 Section 5.1(d)	Pass
Band Edge	RSS-GEN Section 8.10 RSS-247 Section 5.5	Pass
Spurious Emission	RSS-GEN Section 6.13 RSS-247 Section 5.5	Pass
<p>Remark:</p> <ol style="list-style-type: none"> 1. Pass: The EUT complies with the essential requirements in the standard. 2. N/A: Not Applicable. 3. The cable insertion loss used by "RF Output Power" and other conduction measurement items is 1.0dB (provided by the customer). 		
Test Method:	ANSI C63.4-2014 ANSI C63.10-2013 KDB 558074 D01 15.247 Meas Guidance v05r02	

5 General Information

5.1 Client Information

Applicant:	8Devices
Address:	Gedimino 47, Kaunas, LT-44242, Lithuania
Manufacturer/ Factory:	UAB 8Devices
Address:	Antakalnio 17, Vilnius, LT-10312, Lithuania

5.2 General Description of E.U.T.

Product Name:	Komikan
Model No.:	Komikan
Operation Frequency:	2402MHz~2480MHz
Transfer rate:	1/2/3 Mbits/s
Number of channel:	79
Modulation type:	GFSK, $\pi/4$ -DQPSK, 8DPSK
Modulation technology:	FHSS
Antenna Type:	Ceramic Antenna, Whip Antenna, Flex Antenna
Antenna gain:	ceramic antenna: 2.09 dBi Flex antenna: 3.2 dBi whip antenna: 4.0 dBi
Power supply:	DC 3.3V
Test Sample Condition:	The test samples were provided in good working order with no visible defects.

Operation Frequency each of channel for GFSK, $\pi/4$ -DQPSK, 8DPSK							
Channel	Frequency	Channel	Frequency	Channel	Frequency	Channel	Frequency
0	2402MHz	20	2422MHz	40	2442MHz	60	2462MHz
1	2403MHz	21	2423MHz	41	2443MHz	61	2463MHz
2	2404MHz	22	2424MHz	42	2444MHz	62	2464MHz
3	2405MHz	23	2425MHz	43	2445MHz	63	2465MHz
4	2406MHz	24	2426MHz	44	2446MHz	64	2466MHz
5	2407MHz	25	2427MHz	45	2447MHz	65	2467MHz
...
15	2417MHz	35	2437MHz	55	2457MHz	75	2477MHz
16	2418MHz	36	2438MHz	56	2458MHz	76	2478MHz
17	2419MHz	37	2439MHz	57	2459MHz	77	2479MHz
18	2420MHz	38	2440MHz	58	2460MHz	78	2480MHz
19	2421MHz	39	2441MHz	59	2461MHz		

Remark: Channel 0, 39 & 78 selected for GFSK, $\pi/4$ -DQPSK and 8DPSK.

5.3 Test environment and test mode

Operating Environment:	
Temperature:	24.0 °C
Humidity:	54 % RH
Atmospheric Pressure:	1010 mbar
Test Modes:	
Non-hopping mode:	Keep the EUT in continuous transmitting mode with worst case data rate.
Hopping mode:	Keep the EUT in hopping mode.
<p>Remark:</p> <ol style="list-style-type: none"> 1. GFSK (1 Mbps) is the worst case mode. 2. Conducted Emission and Radiated Emission below 1GHz pre-scan Ceramic Antenna and Flex Antenna and Whip Antenna, found Whip Antenna was worse case mode, the report only reflects the worst mode. <p>The sample was placed 0.8m (below 1GHz)/1.5m (above 1GHz) above the ground plane of 3m chamber*. Measurements in both horizontal and vertical polarities were performed. During the test, each emission was maximized by: having the EUT continuously working, investigated all operating modes, rotated about all 3 axis (X, Y & Z) and considered typical configuration to obtain worst position, manipulating interconnecting cables, rotating the turntable, varying antenna height from 1m to 4m in both horizontal and vertical polarizations. The emissions worst-case are shown in Test Results of the following pages.</p>	

5.4 Description of Support Units

Manufacturer	Description	Model	Serial Number	FCC ID/DoC
DELL	PC	OPTIPLEX7070	2J8XSZ2	DoC
DELL	MONITOR	SE2018HR	3M7QPY2	DoC
DELL	KEYBOARD	KB216d	N/A	DoC
DELL	MOUSE	MS116t1	N/A	DoC

Test Software:	Putty	Power setting command	bt_mp_SetParam 0x07,0x15
----------------	-------	-----------------------	--------------------------

5.5 Measurement Uncertainty

Parameters	Expanded Uncertainty
Conducted Emission (9kHz ~ 30MHz)	±1.60 dB (k=2)
Radiated Emission (9kHz ~ 30MHz)	±3.12 dB (k=2)
Radiated Emission (30MHz ~ 1000MHz)	±4.32 dB (k=2)
Radiated Emission (1GHz ~ 18GHz)	±5.38 dB (k=2)
Radiated Emission (18GHz ~ 40GHz)	±3.36 dB (k=2)

5.6 Additions to, deviations, or exclusions from the method

No

5.7 Laboratory Facility

The test facility is recognized, certified, or accredited by the following organizations:

● **FCC - Designation No.: CN1211**

Shenzhen Zhongjian Nanfang Testing Co., Ltd. has been accredited as a testing laboratory by FCC(Federal Communications Commission). The test firm Registration No. is 727551.

● **ISED – CAB identifier.: CN0021**

The 3m Semi-anechoic chamber of Shenzhen Zhongjian Nanfang Testing Co., Ltd. has been Registered by Certification and Engineering Bureau of Industry Canada for radio equipment testing with Registration No.: 10106A-1.

● **CNAS - Registration No.: CNAS L6048**

Shenzhen Zhongjian Nanfang Testing Co., Ltd. is accredited to ISO/IEC 17025:2005 General Requirements for the Competence of Testing and Calibration laboratories for the competence of testing. The Registration No. is CNAS L6048.

● **A2LA - Registration No.: 4346.01**

This laboratory is accredited in accordance with the recognized International Standard ISO/IEC 17025:2005 General requirements for the competence of testing and calibration laboratories. The test scope can be found as below link: <https://portal.a2la.org/scopepdf/4346-01.pdf>

5.8 Laboratory Location

Shenzhen Zhongjian Nanfang Testing Co., Ltd.
Address: No. B-C, 1/F., Building 2, Laodong No.2 Industrial Park, Xixiang Road,
Bao'an District, Shenzhen, Guangdong, China
Tel: +86-755-23118282, Fax: +86-755-23116366
Email: info@ccis-cb.com, Website: <http://www.ccis-cb.com>

5.9 Test Instruments list

Radiated Emission:					
Test Equipment	Manufacturer	Model No.	Serial No.	Cal. Date (mm-dd-yy)	Cal. Due date (mm-dd-yy)
3m SAC	SAEMC	9m*6m*6m	966	07-22-2017	07-21-2020
Loop Antenna	SCHWARZBECK	FMZB1519B	044	03-07-2020	03-06-2021
BiConiLog Antenna	SCHWARZBECK	VULB9163	497	03-07-2020	03-06-2021
Horn Antenna	SCHWARZBECK	BBHA9120D	916	03-07-2020	03-06-2021
Horn Antenna	SCHWARZBECK	BBHA9120D	1805	06-22-2017	06-21-2020
Horn Antenna	SCHWARZBECK	BBHA 9170	BBHA9170582	11-18-2019	11-17-2020
EMI Test Software	AUDIX	E3	Version: 6.110919b		
Pre-amplifier	HP	8447D	2944A09358	03-07-2020	03-06-2021
Pre-amplifier	CD	PAP-1G18	11804	03-07-2020	03-06-2021
Spectrum analyzer	Rohde & Schwarz	FSP30	101454	03-05-2020	03-04-2021
Spectrum analyzer	Rohde & Schwarz	FSP40	100363	11-18-2019	11-17-2020
EMI Test Receiver	Rohde & Schwarz	ESRP7	101070	03-05-2020	03-04-2021
Cable	ZDECL	Z108-NJ-NJ-81	1608458	03-07-2020	03-06-2021
Cable	MICRO-COAX	MFR64639	K10742-5	03-07-2020	03-06-2021
Cable	SUHNER	SUCOFLEX100	58193/4PE	03-07-2020	03-06-2021
RF Switch Unit	MWRFTTEST	MW200	N/A	N/A	N/A
Test Software	MWRFTTEST	MTS8200	Version: 2.0.0.0		

Conducted Emission:					
Test Equipment	Manufacturer	Model No.	Serial No.	Cal. Date (mm-dd-yy)	Cal. Due date (mm-dd-yy)
EMI Test Receiver	Rohde & Schwarz	ESCI	101189	03-05-2020	03-04-2021
Pulse Limiter	SCHWARZBECK	OSRAM 2306	9731	03-05-2020	03-04-2021
LISN	CHASE	MN2050D	1447	03-05-2020	03-04-2021
LISN	Rohde & Schwarz	ESH3-Z5	8438621/010	07-21-2017	07-20-2020
Cable	HP	10503A	N/A	03-05-2020	03-04-2021
EMI Test Software	AUDIX	E3	Version: 6.110919b		

6 Test results and measurement data

6.1 Conducted Emissions

Test Requirement:	RSS-GEN Section 8.8		
Test Frequency Range:	150 kHz to 30 MHz		
Class / Severity:	Class B		
Receiver setup:	RBW=9 kHz, VBW=30 kHz, Sweep time=auto		
Limit:	Frequency range (MHz)	Limit (dBuV)	
		Quasi-peak	Average
	0.15-0.5	66 to 56*	56 to 46*
	0.5-5	56	46
	5-30	60	50
* Decreases with the logarithm of the frequency.			
Test setup:	<p><i>Remark</i> E.U.T: Equipment Under Test LISN: Line Impedance Stabilization Network Test table height=0.8m</p>		
Test procedure:	<ol style="list-style-type: none"> 1. The E.U.T and simulators are connected to the main power through a line impedance stabilization network (L.I.S.N.). This provides a 50ohm/50uH coupling impedance for the measuring equipment. 2. The peripheral devices are also connected to the main power through a LISN that provides a 50ohm/50uH coupling impedance with 50ohm termination. (Please refer to the block diagram of the test setup and photographs). 3. Both sides of A.C. line are checked for maximum conducted interference. In order to find the maximum emission, the relative positions of equipment and all of the interface cables must be changed according to ANSI C63.10(latest version) on conducted measurement. 		
Test Instruments:	Refer to section 5.9 for details		
Test mode:	Hopping mode		
Test results:	Pass		

Measurement Data:

Product name:	Komikan	Product model:	Komikan
Test by:	Mike	Test mode:	BT Tx mode
Test frequency:	150 kHz ~ 30 MHz	Phase:	Line
Test voltage:	AC 120 V/60 Hz	Environment:	Temp: 22.5°C Huni: 55%

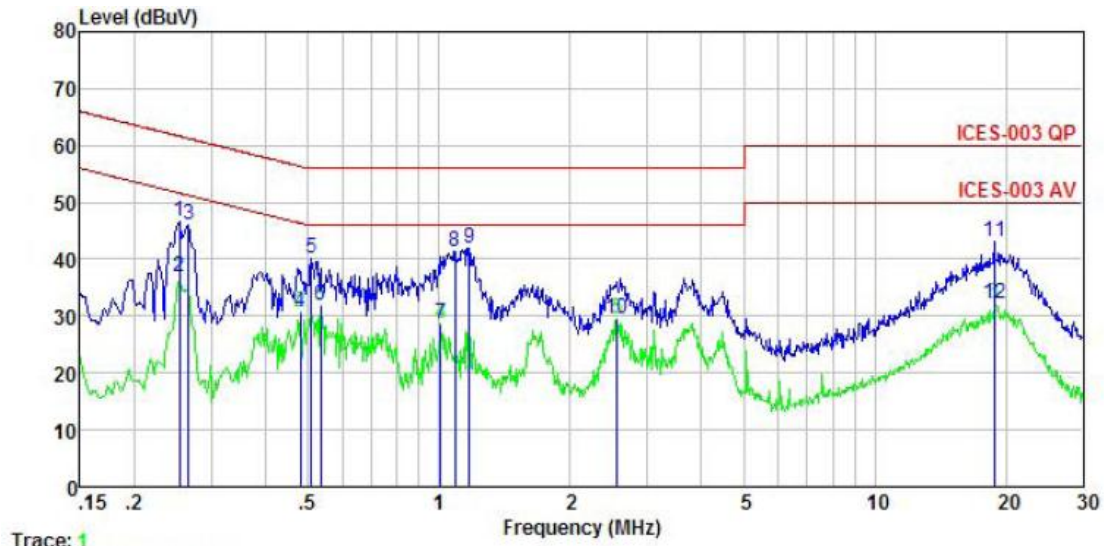

Trace: 1

	Freq	Read Level	LISN Factor	Aux Factor	Cable Loss	Level	Limit Line	Over Limit	Remark
	MHz	dBuV	dB	dB	dB	dBuV	dBuV	dB	
1	0.253	36.40	-0.40	-0.22	10.75	46.53	61.64	-15.11	QP
2	0.253	26.70	-0.40	-0.22	10.75	36.83	51.64	-14.81	Average
3	0.266	36.06	-0.39	-0.23	10.75	46.19	61.25	-15.06	QP
4	0.481	20.63	-0.39	-0.24	10.75	30.75	46.32	-15.57	Average
5	0.510	30.25	-0.39	-0.35	10.76	40.27	56.00	-15.73	QP
6	0.535	21.90	-0.39	-0.36	10.76	31.91	46.00	-14.09	Average
7	1.010	17.60	-0.38	0.45	10.87	28.54	46.00	-17.46	Average
8	1.088	30.36	-0.38	0.37	10.88	41.23	56.00	-14.77	QP
9	1.172	31.21	-0.39	0.29	10.89	42.00	56.00	-14.00	QP
10	2.567	19.11	-0.43	-0.25	10.94	29.37	46.00	-16.63	Average
11	18.820	31.69	-0.91	1.43	10.92	43.13	60.00	-16.87	QP
12	18.820	20.81	-0.91	1.43	10.92	32.25	50.00	-17.75	Average

Notes:

1. An initial pre-scan was performed on the line and neutral lines with peak detector.
2. Quasi-Peak and Average measurement were performed at the frequencies with maximized peak emission.
3. Final Level = Receiver Read level + LISN Factor + Aux Factor + Cable Loss.

Product name:	Komikan	Product model:	Komikan
Test by:	Mike	Test mode:	BT Tx mode
Test frequency:	150 kHz ~ 30 MHz	Phase:	Neutral
Test voltage:	AC 120 V/60 Hz	Environment:	Temp: 22.5°C Humi: 55%

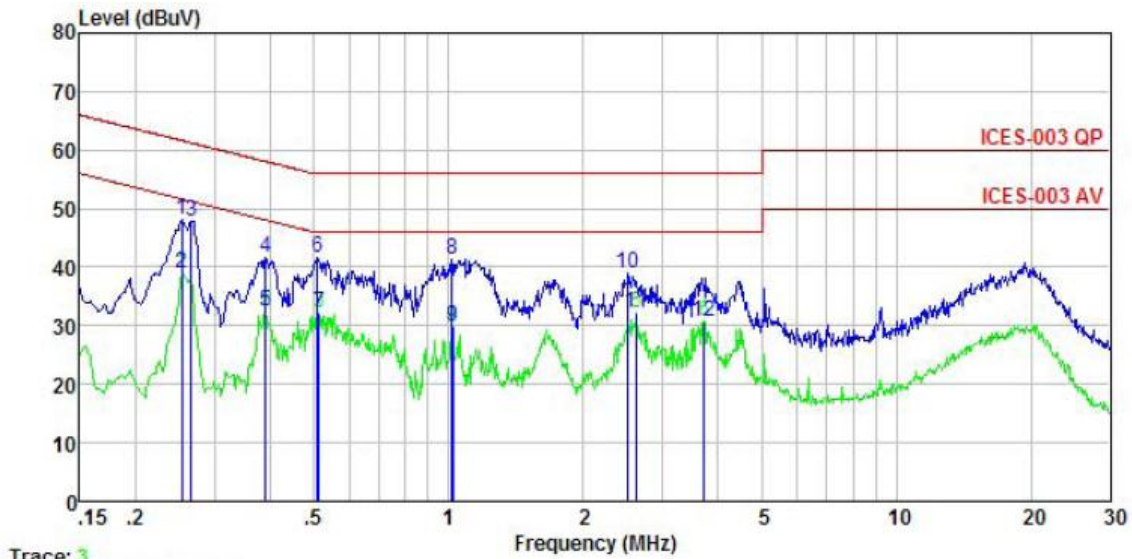

	Read Freq	Level	LISN Factor	Aux Factor	Cable Loss	Level	Limit Line	Over Limit	Remark
	MHz	dBuV	dB	dB	dB	dBuV	dBuV	dB	
1	0.253	38.10	-0.65	0.01	10.75	48.21	61.64	-13.43	QP
2	0.253	28.86	-0.65	0.01	10.75	38.97	51.64	-12.67	Average
3	0.266	37.73	-0.65	0.01	10.75	47.84	61.25	-13.41	QP
4	0.389	31.58	-0.64	-0.05	10.72	41.61	58.08	-16.47	QP
5	0.389	22.33	-0.64	-0.05	10.72	32.36	48.08	-15.72	Average
6	0.510	31.46	-0.65	0.03	10.76	41.60	56.00	-14.40	QP
7	0.513	22.00	-0.65	0.03	10.76	32.14	46.00	-13.86	Average
8	1.021	19.63	-0.63	0.08	10.87	29.95	46.00	-16.05	Average
9	1.021	31.08	-0.63	0.08	10.87	41.40	56.00	-14.60	QP
10	2.513	28.51	-0.67	0.25	10.94	39.03	56.00	-16.97	QP
11	2.636	21.67	-0.67	0.27	10.93	32.20	46.00	-13.80	Average
12	3.720	20.00	-0.69	0.46	10.90	30.67	46.00	-15.33	Average

Notes:

1. An initial pre-scan was performed on the line and neutral lines with peak detector.
2. Quasi-Peak and Average measurement were performed at the frequencies with maximized peak emission.
3. Final Level = Receiver Read level + LISN Factor + Aux Factor + Cable Loss.

6.2 Conducted Output Power

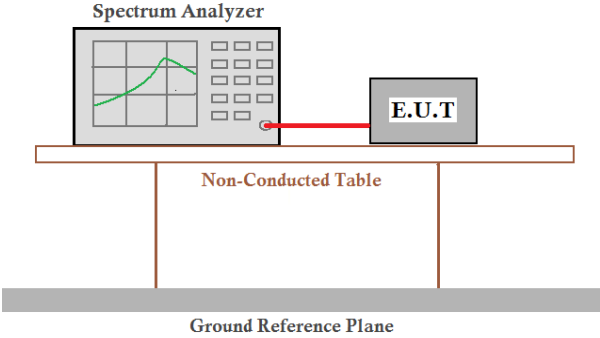
Test Requirement:	RSS-247 Section 5.4(b)
Receiver setup:	RBW=1MHz, VBW=3MHz, Detector=Peak (If 20dB BW ≤1 MHz) RBW=3MHz, VBW=10MHz, Detector=Peak (If 20dB BW > 1 MHz and < 3MHz)
Limit:	For FHSs operating in the band 2400-2483.5 MHz, the maximum peak conducted output power shall not exceed 1.0 W if the hopset uses 75 or more hopping channels; the maximum peak conducted output power shall not exceed 0.125 W if the hopset uses less than 75 hopping channels. The e.i.r.p. shall not exceed 4 W.
Test setup:	 <p>The diagram illustrates the test setup. A Spectrum Analyzer is connected via a red cable to an E.U.T. (Equipment Under Test). Both are placed on a Non-Conducted Table. Below the table is a Ground Reference Plane.</p>
Test Instruments:	Refer to section 5.9 for details
Test mode:	Non-hopping mode
Test results:	Pass

Measurement Data:

Ceramic Antenna:

Test channel	Peak Output Power (dBm)	Limit (dBm)	Ant. Gain (dBi)	EIRP (dBm)	EIRP Limit (dBm)	Result
GFSK mode						
Lowest channel	5.02	30.00	2.09	7.11	36.0	Pass
Middle channel	5.47	30.00	2.09	7.56	36.0	Pass
Highest channel	4.98	30.00	2.09	7.07	36.0	Pass
π/4-DQPSK mode						
Lowest channel	6.07	21.00	2.09	8.16	36.0	Pass
Middle channel	6.78	21.00	2.09	8.87	36.0	Pass
Highest channel	6.29	21.00	2.09	8.38	36.0	Pass
8DPSK mode						
Lowest channel	6.38	21.00	2.09	8.47	36.0	Pass
Middle channel	7.14	21.00	2.09	9.23	36.0	Pass
Highest channel	6.68	21.00	2.09	8.77	36.0	Pass

Flex Antenna:

Test channel	Peak Output Power (dBm)	Limit (dBm)	Ant. Gain (dBi)	EIRP (dBm)	EIRP Limit (dBm)	Result
GFSK mode						
Lowest channel	5.02	30.00	3.2	8.22	36.02	Pass
Middle channel	5.47	30.00	3.2	8.67	36.02	Pass
Highest channel	4.98	30.00	3.2	8.18	36.02	Pass
π/4-DQPSK mode						
Lowest channel	6.07	21.00	3.2	9.27	36.02	Pass
Middle channel	6.78	21.00	3.2	9.98	36.02	Pass
Highest channel	6.29	21.00	3.2	9.49	36.02	Pass
8DPSK mode						
Lowest channel	6.38	21.00	3.2	9.58	36.02	Pass
Middle channel	7.14	21.00	3.2	10.34	36.02	Pass
Highest channel	6.68	21.00	3.2	9.88	36.02	Pass

Whip Antenna:

Test channel	Peak Output Power (dBm)	Limit (dBm)	Ant. Gain (dBi)	EIRP (dBm)	EIRP Limit (dBm)	Result
GFSK mode						
Lowest channel	5.02	30.00	4.0	9.02	36.02	Pass
Middle channel	5.47	30.00	4.0	9.47	36.02	Pass
Highest channel	4.98	30.00	4.0	8.98	36.02	Pass
π/4-DQPSK mode						
Lowest channel	6.07	21.00	4.0	10.07	36.02	Pass
Middle channel	6.78	21.00	4.0	10.78	36.02	Pass
Highest channel	6.29	21.00	4.0	10.29	36.02	Pass
8DPSK mode						
Lowest channel	6.38	21.00	4.0	10.38	36.02	Pass
Middle channel	7.14	21.00	4.0	11.14	36.02	Pass
Highest channel	6.68	21.00	4.0	10.68	36.02	Pass

Test plot as follows:

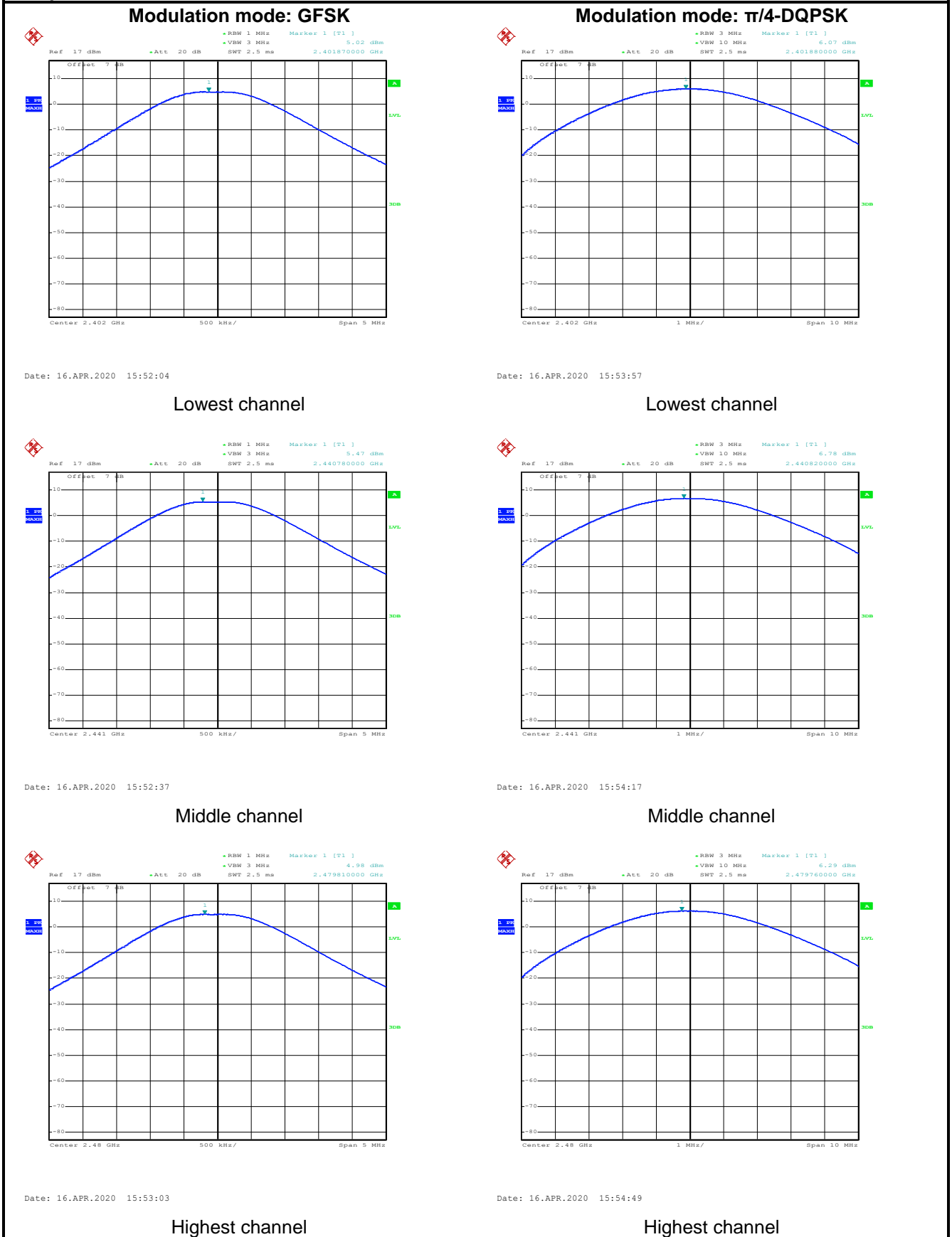

Modulation mode: 8DPSK

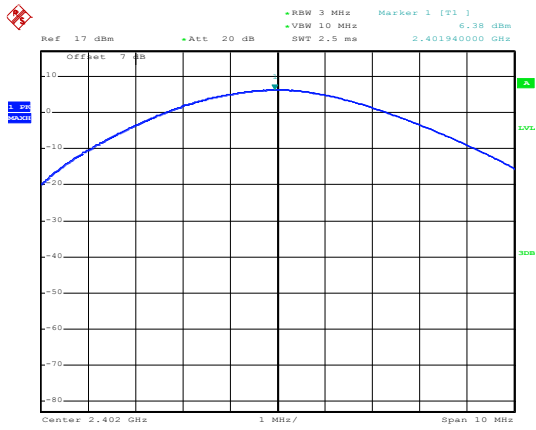

Date: 16.APR.2020 15:56:15

Lowest channel

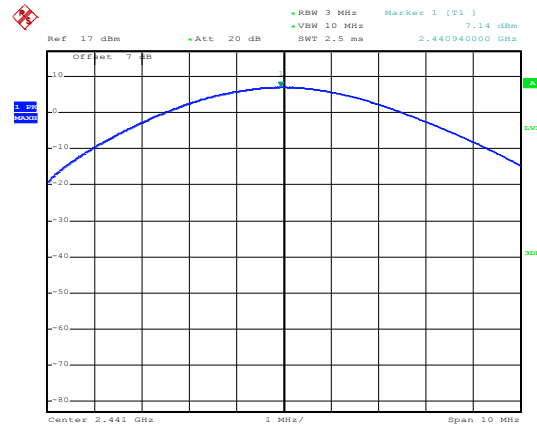

Date: 16.APR.2020 15:55:51

Middle channel

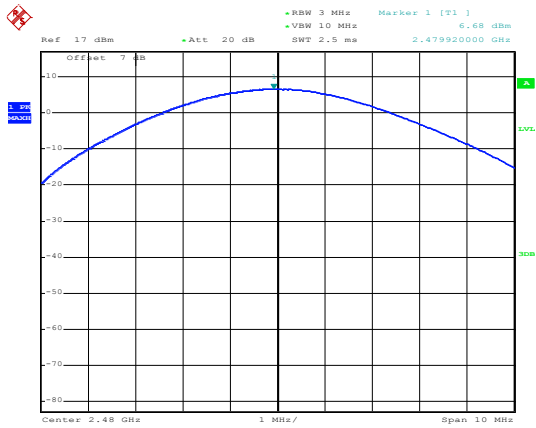

Date: 16.APR.2020 15:55:22

Highest channel

6.3 Occupy Bandwidth

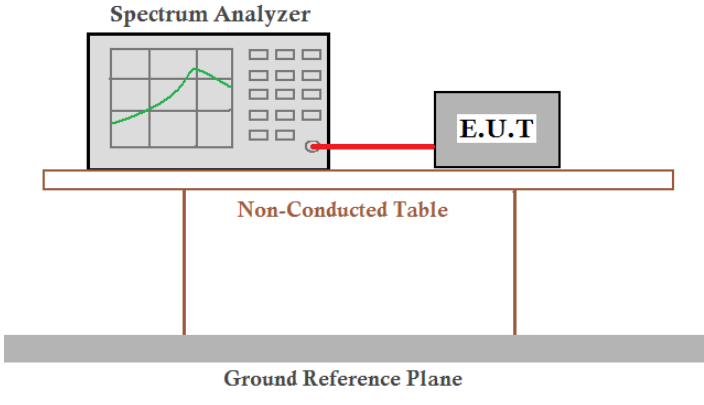
Test Requirement:	RSS-247 Section 5.1(a)
Receiver setup:	RBW=30 kHz, VBW=100 kHz, detector=Peak
Limit:	N/A
Test setup:	 <p>The diagram illustrates the test setup. A Spectrum Analyzer is connected via a red cable to an E.U.T. (Equipment Under Test). Both are placed on a Non-Conducted Table. Below the table is a Ground Reference Plane.</p>
Test Instruments:	Refer to section 5.9 for details
Test mode:	Non-hopping mode
Test results:	Pass

Measurement Data:

Test channel	20dB Occupy Bandwidth (kHz)		
	GFSK	$\pi/4$ -DQPSK	8DPSK
Lowest	928	1248	1278
Middle	928	1254	1272
Highest	932	1248	1272
Test channel	99% Occupy Bandwidth (kHz)		
	GFSK	$\pi/4$ -DQPSK	8DPSK
Lowest	828	1140	1158
Middle	828	1146	1164
Highest	832	1146	1164

Test plot as follows:

Test mode: 20dB OBW

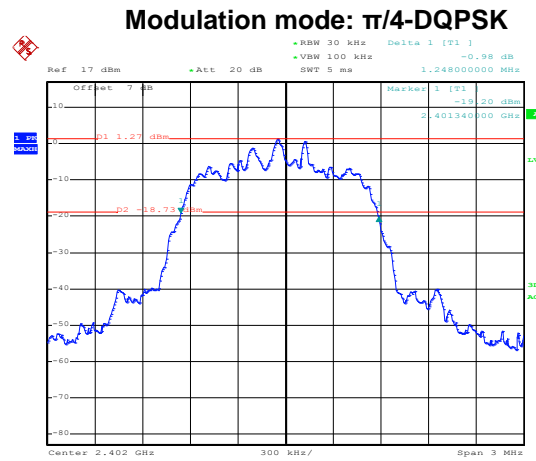
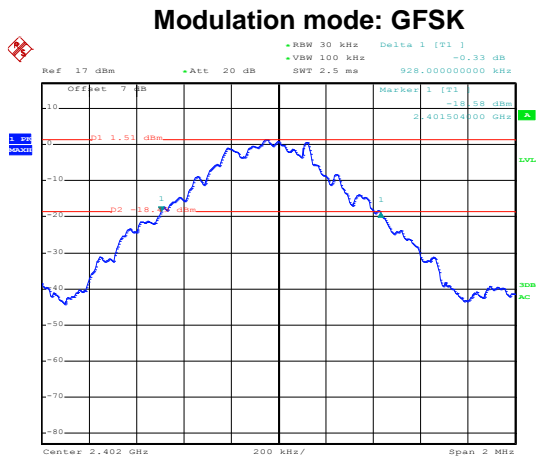

Date: 16.APR.2020 16:03:51

Date: 16.APR.2020 15:28:39

Lowest channel

Lowest channel

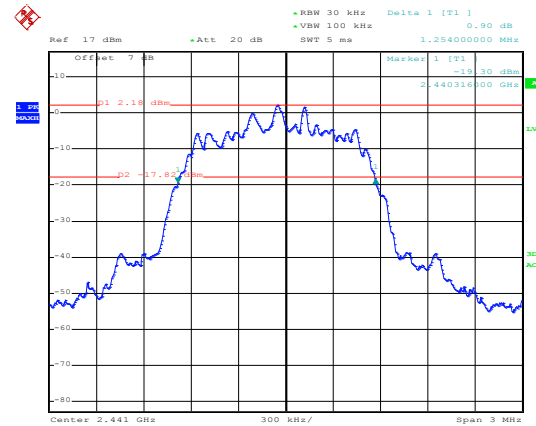
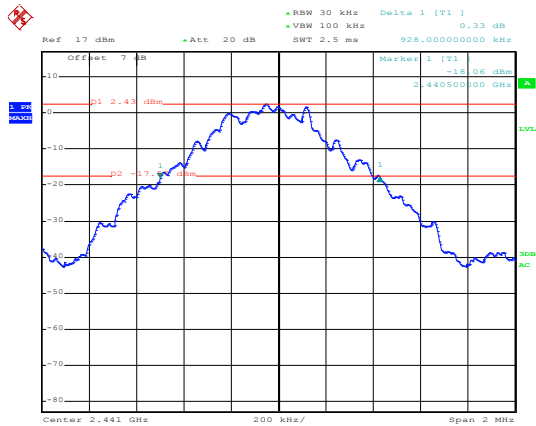

Date: 16.APR.2020 16:05:59

Date: 16.APR.2020 16:09:54

Middle channel

Middle channel

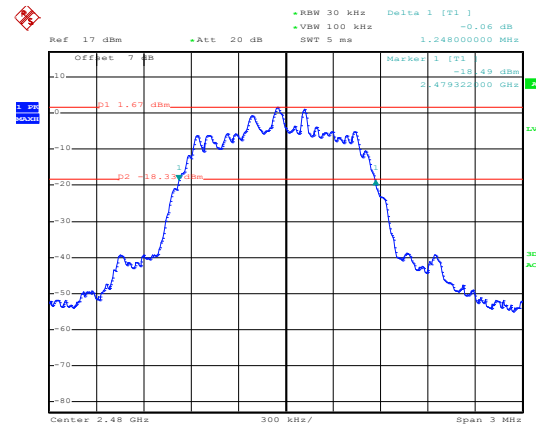
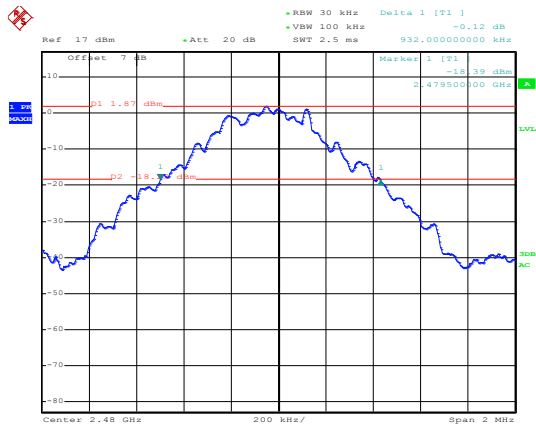

Date: 16.APR.2020 16:06:59

Date: 16.APR.2020 16:08:46

Highest channel

Highest channel

Modulation mode: 8DPSK

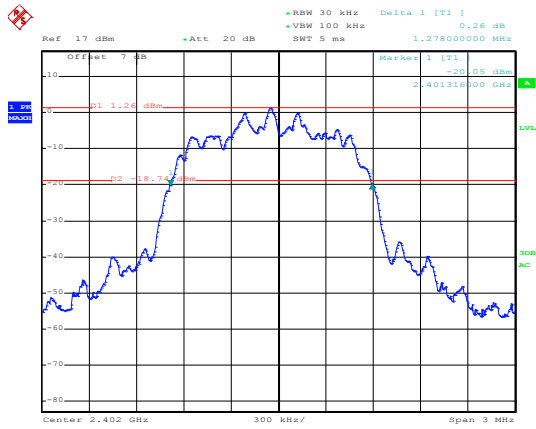

Date: 16.APR.2020 16:12:13

Lowest channel

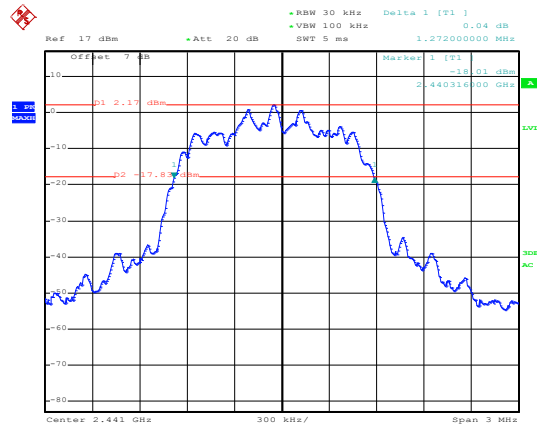

Date: 16.APR.2020 16:13:21

Middle channel

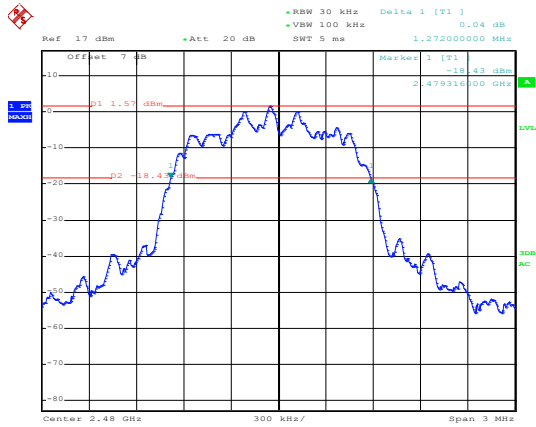

Date: 16.APR.2020 16:14:39

Highest channel

Test mode: 99% OBW

Modulation mode: GFSK

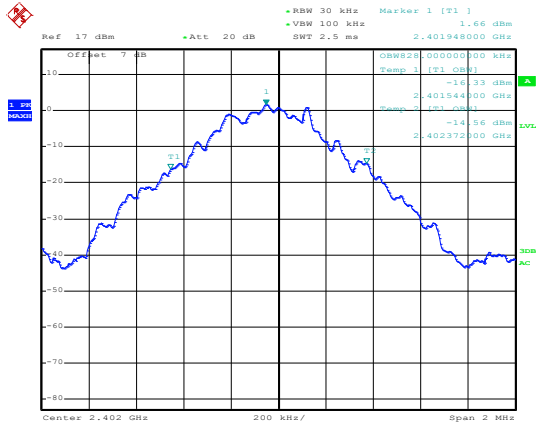

Date: 16.APR.2020 16:04:45

Modulation mode: $\pi/4$ -DQPSK

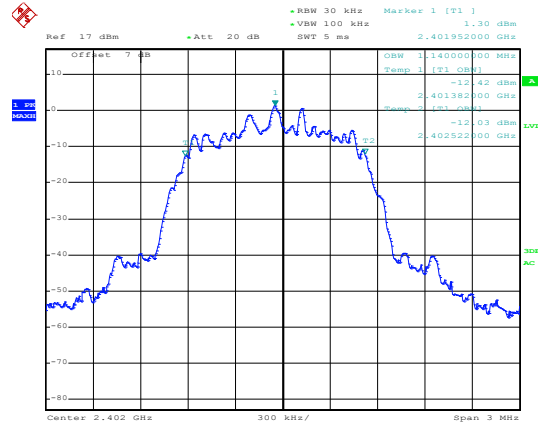

Date: 16.APR.2020 16:10:49

Lowest channel

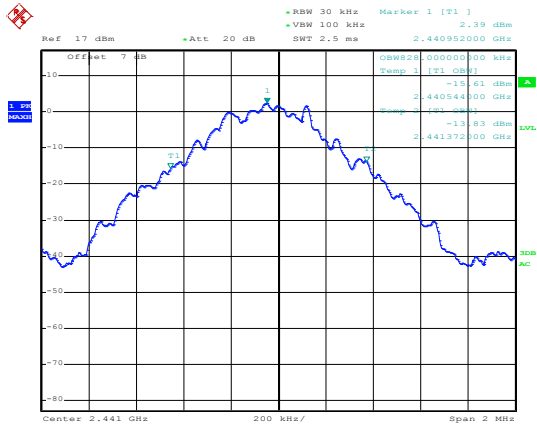

Date: 16.APR.2020 16:05:15

Lowest channel

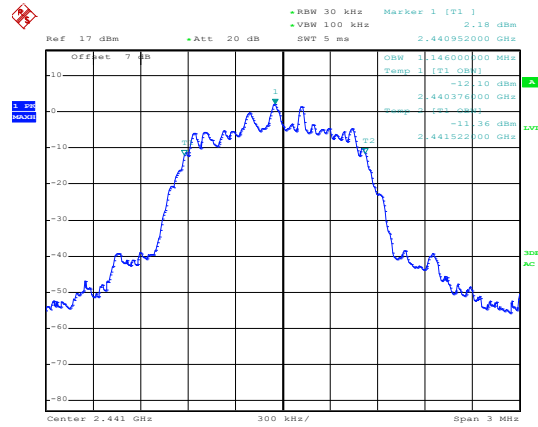

Date: 16.APR.2020 16:10:21

Middle channel

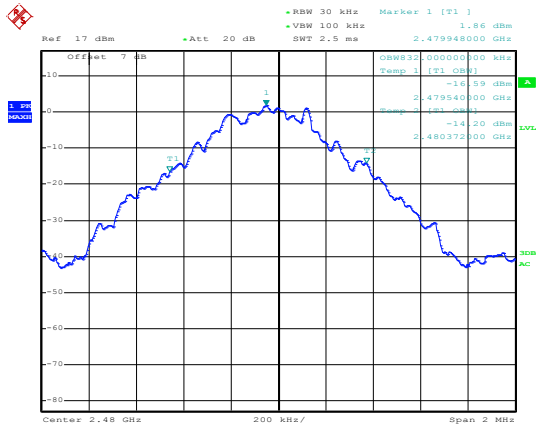

Date: 16.APR.2020 16:07:24

Middle channel

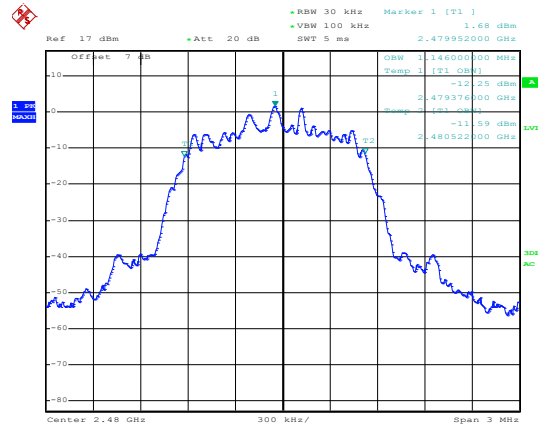

Date: 16.APR.2020 16:08:01

Highest channel

Highest channel

Modulation mode: 8DPSK

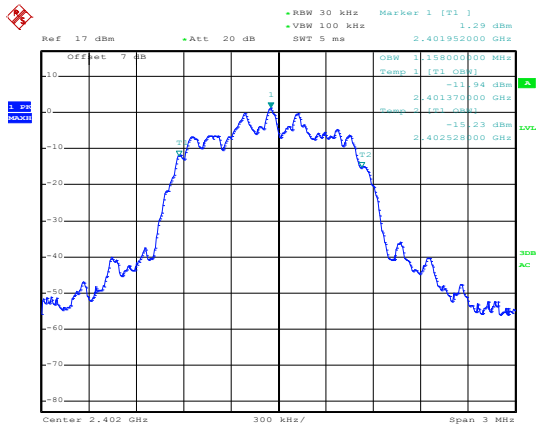

Date: 16.APR.2020 16:11:26

Lowest channel

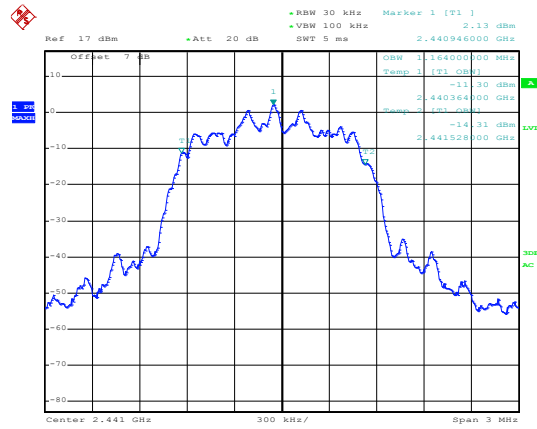

Date: 16.APR.2020 16:13:38

Middle channel

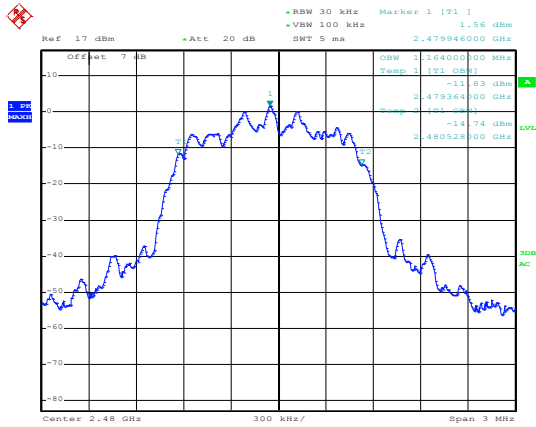

Date: 16.APR.2020 16:14:07

Highest channel

6.4 Carrier Frequencies Separation

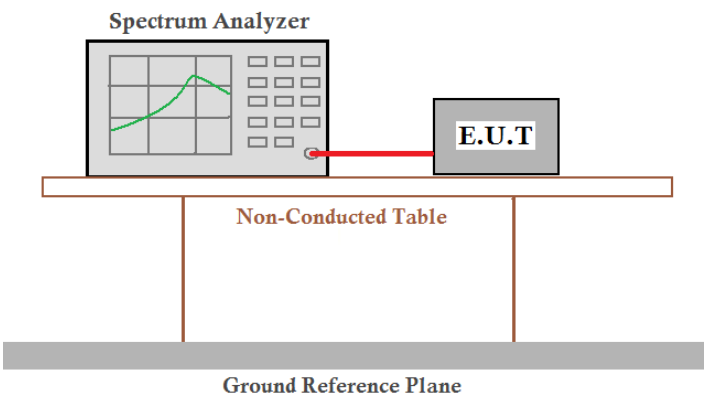
Test Requirement:	RSS-247 Section 5.1(b)
Receiver setup:	RBW=100 kHz, VBW=300 kHz, detector=Peak
Limit:	a) 0.025MHz or the 20dB bandwidth (whichever is greater) b) 0.025MHz or two-thirds of the 20dB bandwidth (whichever is greater)
Test setup:	 <p>The diagram illustrates the test setup. A Spectrum Analyzer is connected to an E.U.T. (Equipment Under Test) via a red cable. Both are placed on a Non-Conducted Table, which is supported by a Ground Reference Plane.</p>
Test Instruments:	Refer to section 5.9 for details
Test mode:	Hopping mode
Test results:	Pass

Measurement Data:

Test channel	Carrier Frequencies Separation (kHz)	Limit (kHz)	Result
GFSK			
Lowest	1004	932.00	Pass
Middle	1004	932.00	Pass
Highest	1004	932.00	Pass
$\pi/4$ -DQPSK mode			
Lowest	1004	836.00	Pass
Middle	1004	836.00	Pass
Highest	1004	836.00	Pass
8DPSK mode			
Lowest	1004	852.00	Pass
Middle	1008	852.00	Pass
Highest	1004	852.00	Pass

Note: According to section 6.4

Mode	20dB bandwidth (kHz) (worse case)	Limit (kHz) (Carrier Frequencies Separation)
GFSK	932	932.00
$\pi/4$ -DQPSK	1254	836.00
8DPSK	1278	852.00

Test plot as follows:

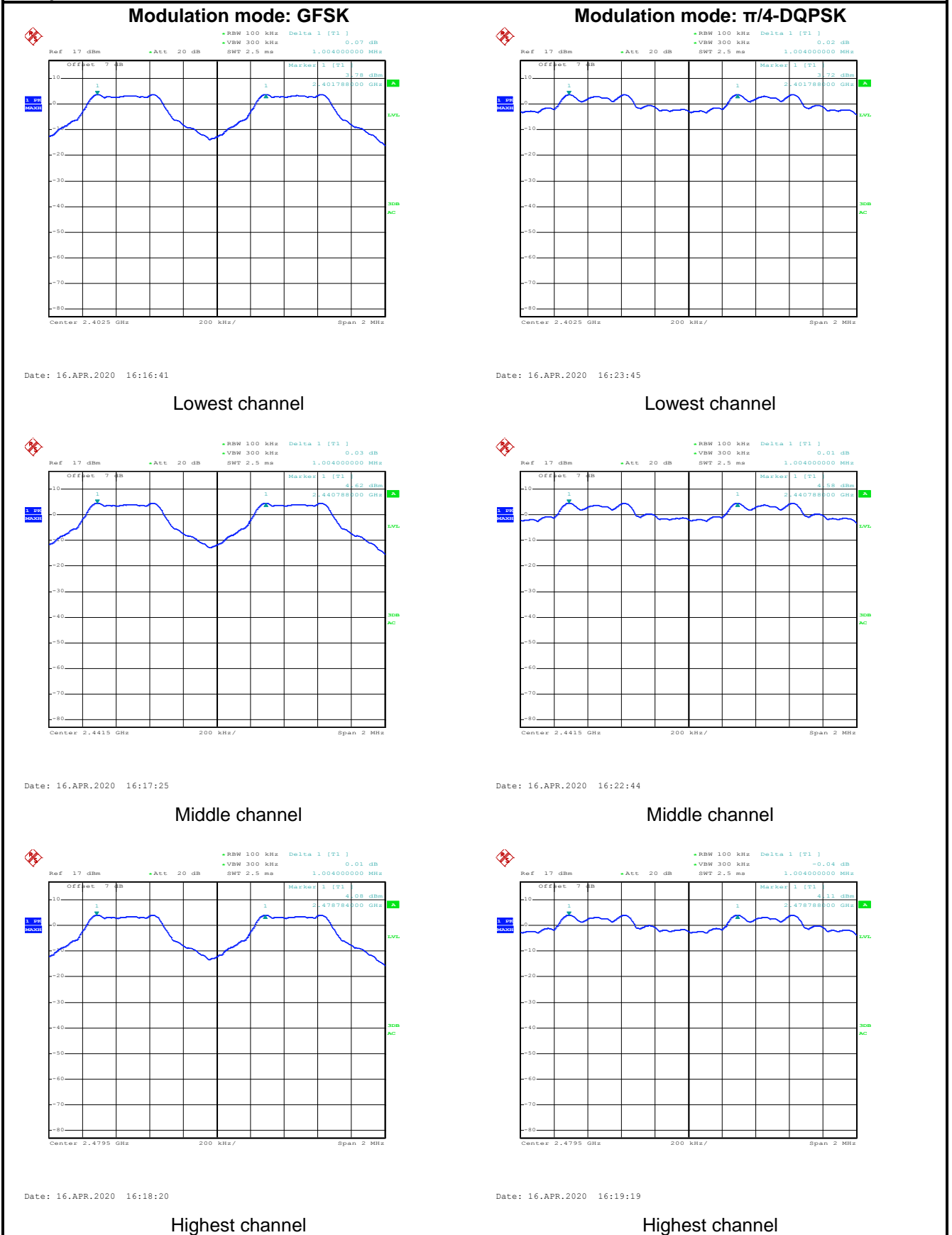

Modulation mode: 8DPSK

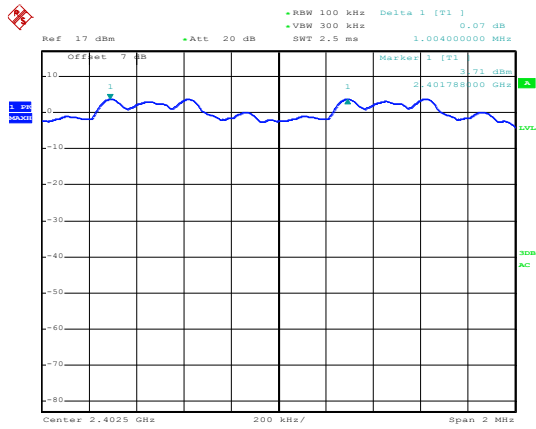

Date: 16.APR.2020 16:24:53

Lowest channel

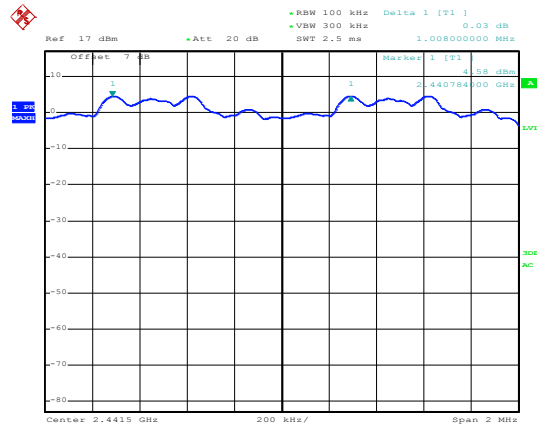

Date: 16.APR.2020 16:21:16

Middle channel

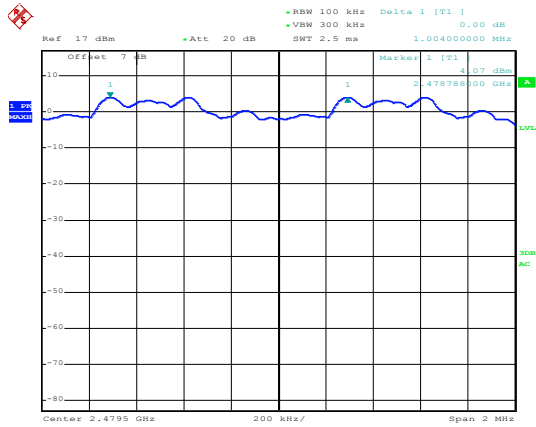

Date: 16.APR.2020 16:20:25

Highest channel

6.5 Hopping Channel Number

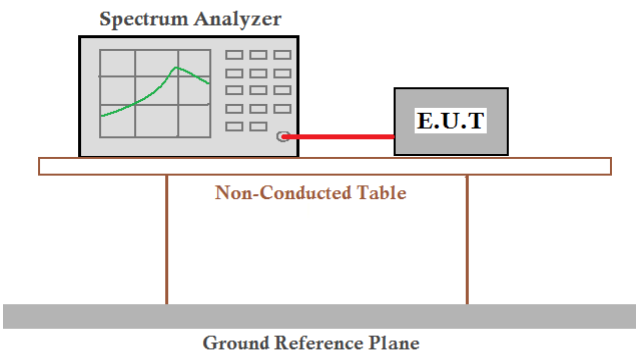
Test Requirement:	RSS-247 Section 5.1(d)
Receiver setup:	RBW=100 kHz, VBW=300 kHz, Frequency range=2400MHz-2483.5MHz, Detector=Peak
Limit:	15 channels
Test setup:	 <p>The diagram shows a Spectrum Analyzer and an E.U.T. (Equipment Under Test) connected by a red cable. They are positioned on a table labeled 'Non-Conducted Table'. Below the table is a 'Ground Reference Plane'.</p>
Test Instruments:	Refer to section 5.9 for details
Test mode:	Hopping mode
Test results:	Pass

Measurement Data:

Mode	Hopping channel numbers	Limit	Result
GFSK, $\pi/4$ -DQPSK, 8DPSK	79	15	Pass

Test plot as follows:

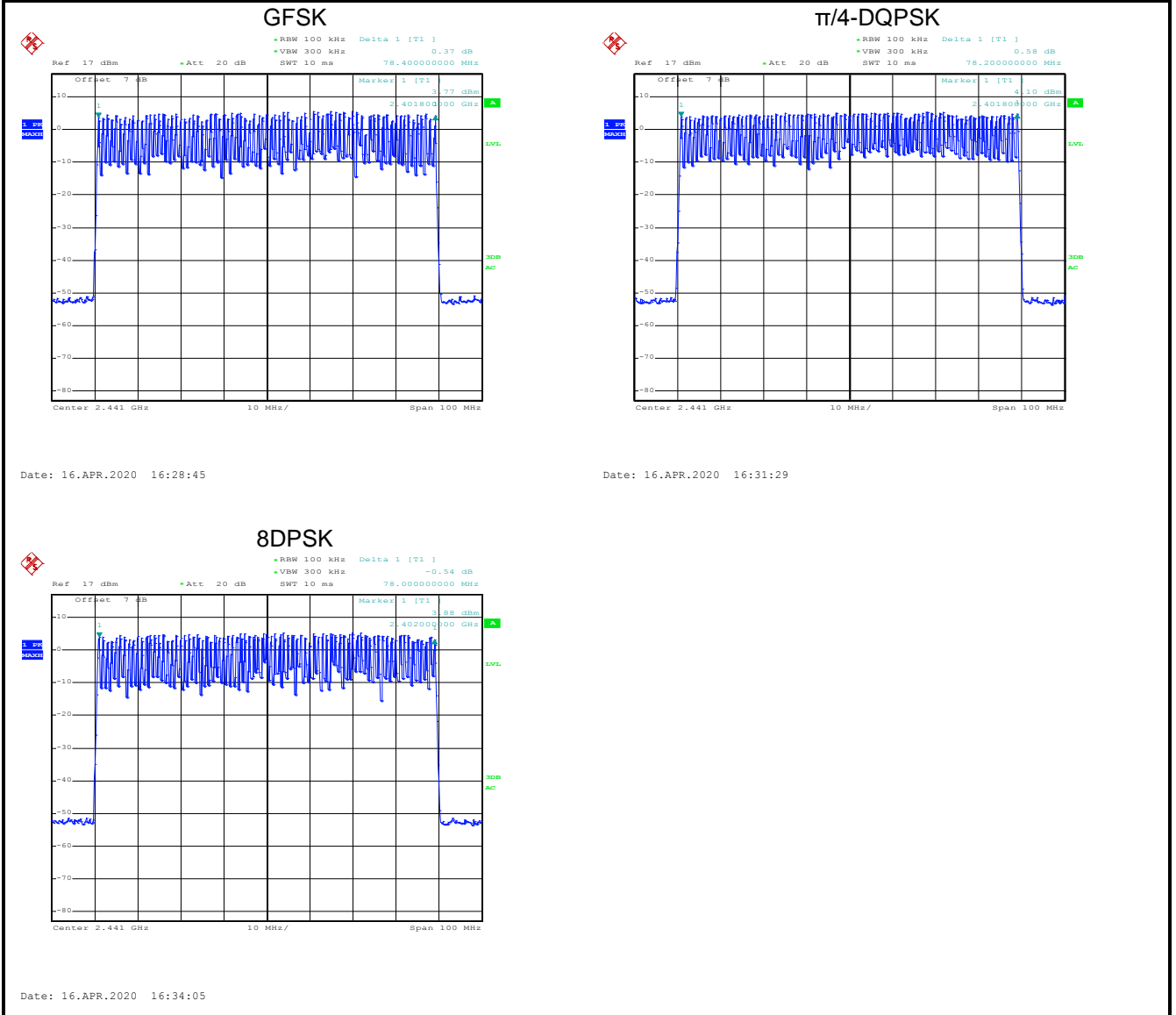

6.6 Dwell Time

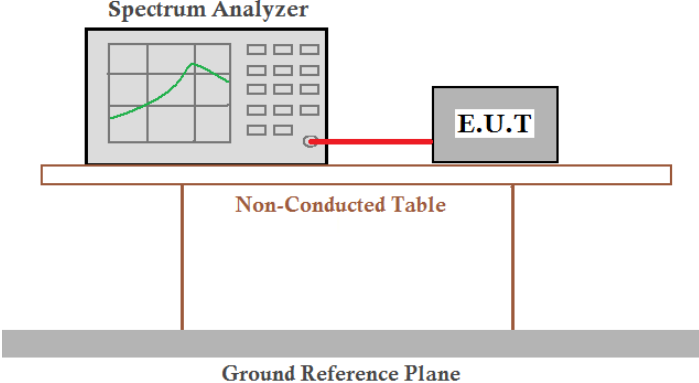
Test Requirement:	RSS-247 Section 5.1(d)
Receiver setup:	RBW=1 MHz, VBW=1 MHz, Span=0 Hz, Detector=Peak
Limit:	0.4 Second
Test setup:	
Test Instruments:	Refer to section 5.9 for details
Test mode:	Hopping mode
Test results:	Pass

Measurement Data (Worse case):

Mode	Packet	Dwell time (second)	Limit (second)	Result
GFSK	DH1	0.12800	0.4	Pass
	DH3	0.26880		
	DH5	0.31168		
π/4-DQPSK	2-DH1	0.13120	0.4	Pass
	2-DH3	0.26976		
	2-DH5	0.31253		
8DPSK	3-DH1	0.13120	0.4	Pass
	3-DH3	0.26784		
	3-DH5	0.31253		

Note:

The test period = 0.4 Second/Channel x 79 Channel = 31.6 s

Calculation Formula: Dwell time = Ton time per hop * Hopping numbers * Period

For example:

DH1 time slot=0.416*(1600/ (2*79)) * 31.6=128.00ms

DH3 time slot=1.686*(1600/ (4*79)) * 31.6=268.80ms

DH5 time slot=2.952*(1600/ (6*79)) * 31.6=311.68ms

Test plot as follows:

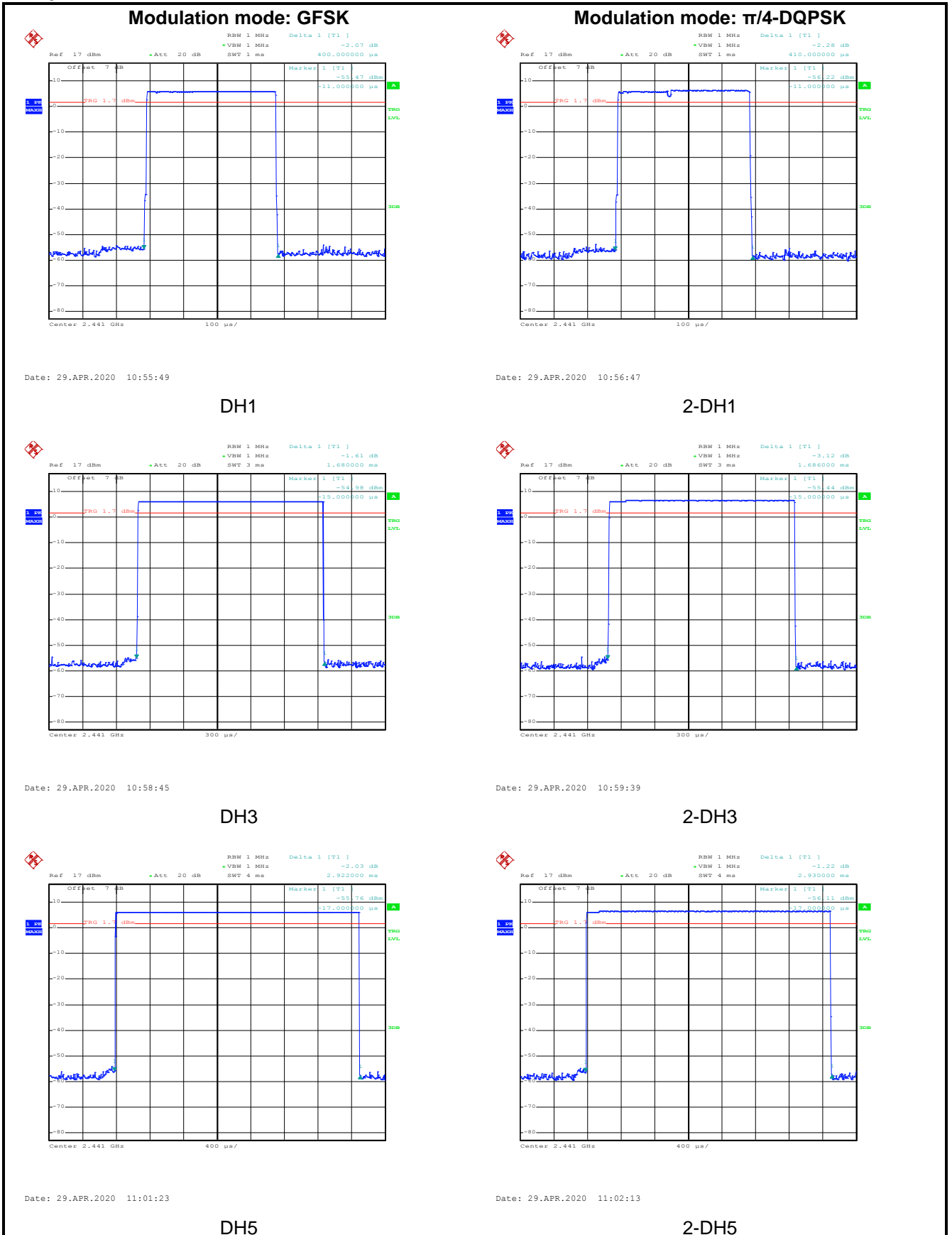

Modulation mode: 8DPSK

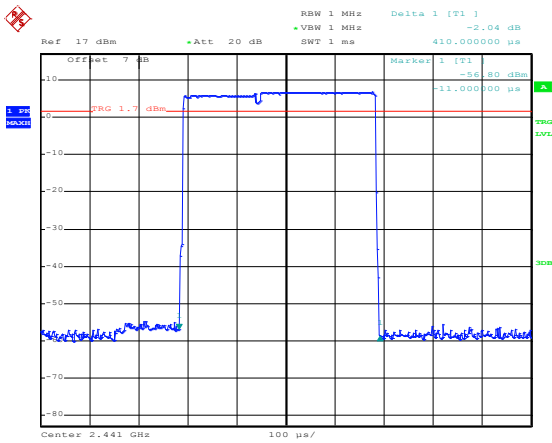

Date: 29.APR.2020 10:57:42

3-DH1

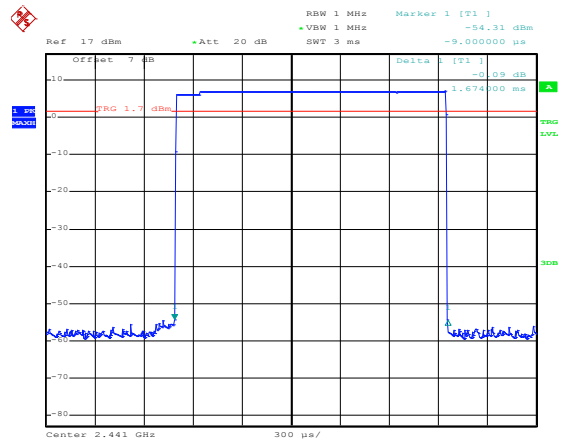

Date: 29.APR.2020 11:00:40

3-DH3

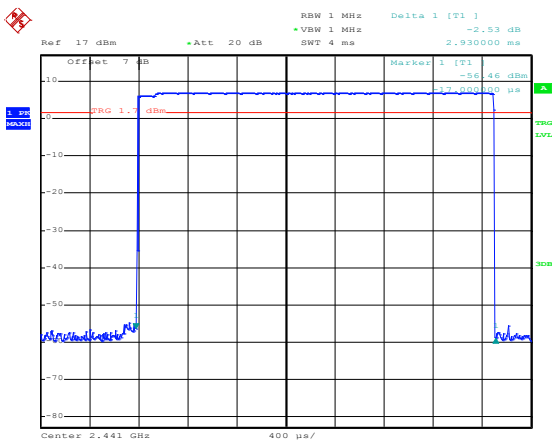

Date: 29.APR.2020 11:02:56

3-DH5

6.7 Pseudorandom Frequency Hopping Sequence

Test Requirement:	RSS-247 Section 5.1(b) requirement:
<p>Frequency hopping systems shall have hopping channel carrier frequencies separated by a minimum of 25 kHz or the 20 dB bandwidth of the hopping channel, whichever is greater.</p> <p>Alternatively. Frequency hopping systems operating in the 2400-2483.5 MHz band may have hopping channel carrier frequencies that are separated by 25 kHz or two-thirds of the 20 dB bandwidth of the hopping channel, whichever is greater, provided the systems operate with an output power no greater than 125 mW. The system shall hop to channel frequencies that are selected at the system hopping rate from a Pseudorandom ordered list of hopping frequencies. Each frequency must be used equally on the average by each transmitter. The system receivers shall have input bandwidths that match the hopping channel bandwidths of their corresponding transmitters and shall shift frequencies in synchronization with the transmitted signals.</p>	
<p>EUT Pseudorandom Frequency Hopping Sequence</p>	
<p>The pseudorandom sequence may be generated in a nine-stage shift register whose 5th and 9th stage outputs are added in a modulo-two addition stage. And the result is fed back to the input of the first stage. The sequence begins with the first ONE of 9 consecutive ONES; i.e. the shift register is initialized with nine ones.</p> <ul style="list-style-type: none"> • Number of shift register stages: 9 • Length of pseudo-random sequence: $2^9 - 1 = 511$ bits • Longest sequence of zeros: 8 (non-inverted signal) <div data-bbox="261 846 1299 990" style="text-align: center;"> </div> <p style="text-align: center;"><i>Linear Feedback Shift Register for Generation of the PRBS sequence</i></p> <p>An example of Pseudorandom Frequency Hopping Sequence as follow:</p> <div data-bbox="261 1093 1244 1236" style="text-align: center;"> </div> <p>Each frequency used equally on the average by each transmitter.</p> <p>The system receivers have input bandwidths that match the hopping channel bandwidths of their corresponding transmitters and shift frequencies in synchronization with the transmitted signals.</p>	

6.8 Band Edge

6.8.1 Conducted Emission Method

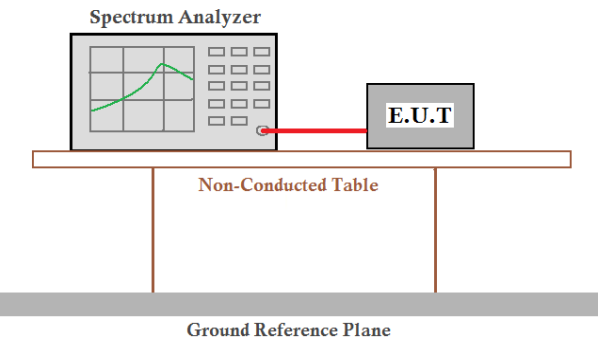
Test Requirement:	RSS-247 Section 5.5
Receiver setup:	RBW=100 kHz, VBW=300 kHz, Detector=Peak
Limit:	In any 100 kHz bandwidth outside the frequency band in which the spread spectrum intentional radiator is operating, the radio frequency power that is produced by the intentional radiator shall be at least 20 dB below that in the 100 kHz bandwidth within the band that contains the highest level of the desired power, based on either an RF conducted or a radiated measurement.
Test setup:	 <p>The diagram illustrates the test setup. A Spectrum Analyzer is connected to an E.U.T. (Equipment Under Test) via a red cable. Both the Spectrum Analyzer and the E.U.T. are placed on a Non-Conducted Table. The table is supported by a Ground Reference Plane.</p>
Test Instruments:	Refer to section 5.9 for details
Test mode:	Non-hopping mode and hopping mode
Test results:	Pass

Test plot as follows:

GFSK Lowest Channel

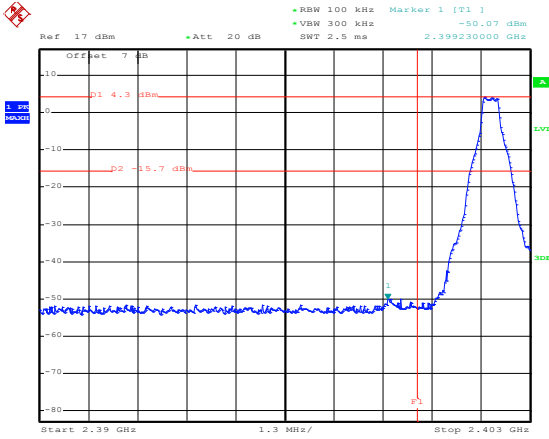

Date: 16.APR.2020 15:30:30

No-hopping mode

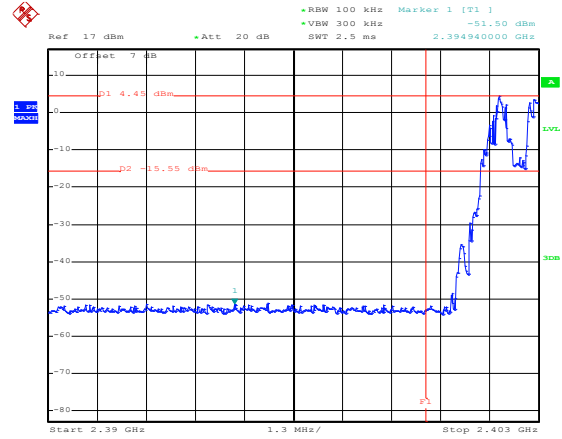

Date: 16.APR.2020 15:32:21

Hopping mode

Highest Channel

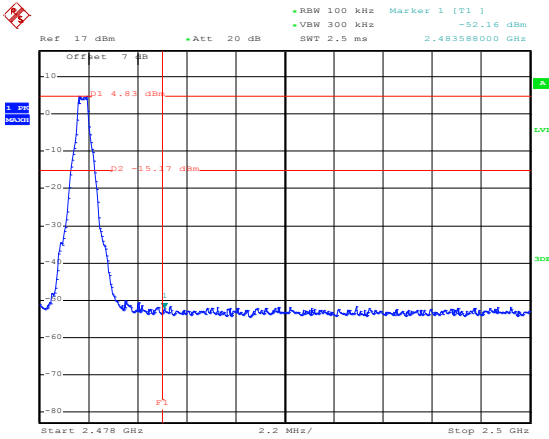

Date: 16.APR.2020 15:39:53

No-hopping mode

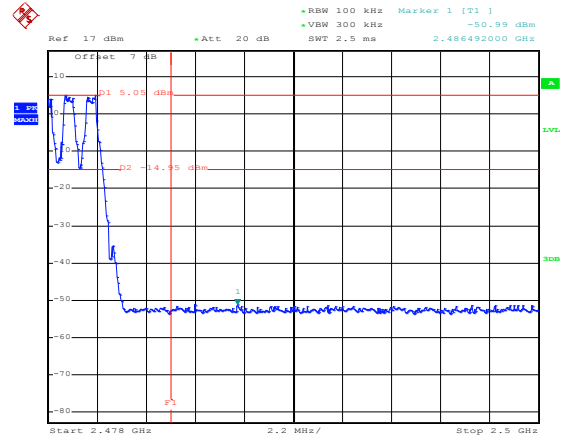

Date: 16.APR.2020 15:44:41

Hopping mode

$\pi/4$ -DQPSK Lowest Channel

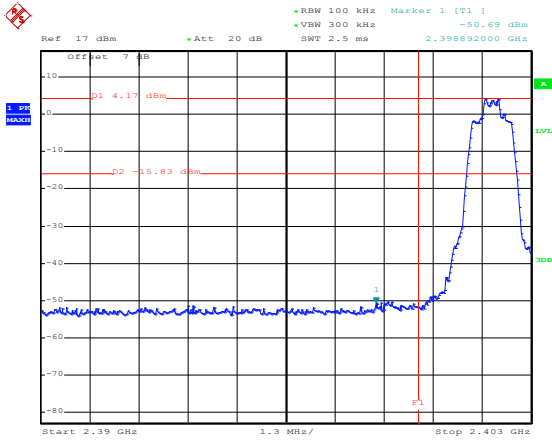

Date: 16.APR.2020 15:35:11

No-hopping mode

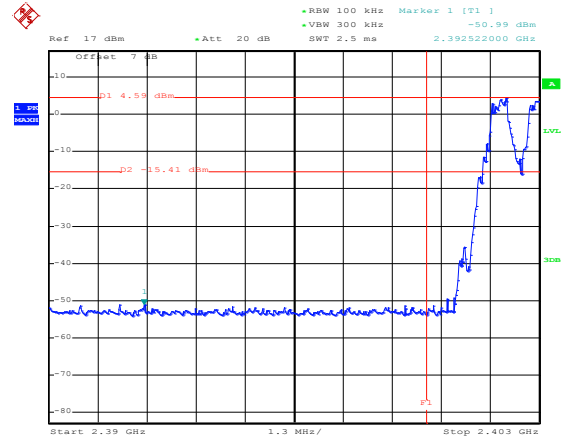

Date: 16.APR.2020 15:33:40

Hopping mode

Highest Channel

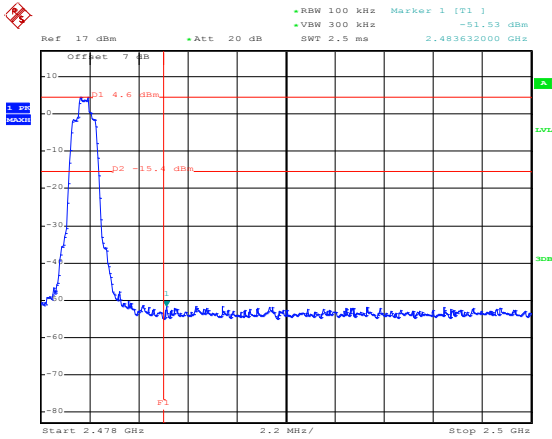

Date: 16.APR.2020 15:47:23

No-hopping mode

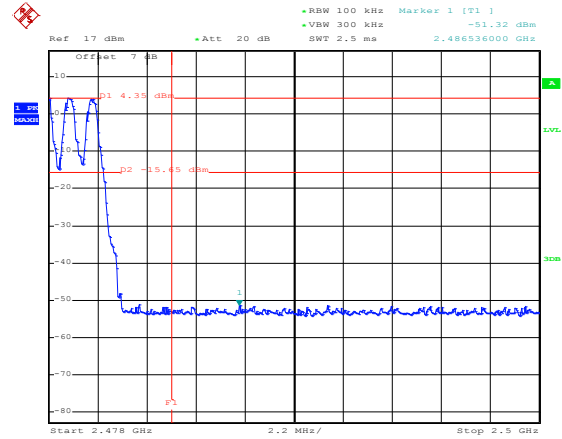

Date: 16.APR.2020 15:46:33

Hopping mode

8DPSK Lowest Channel

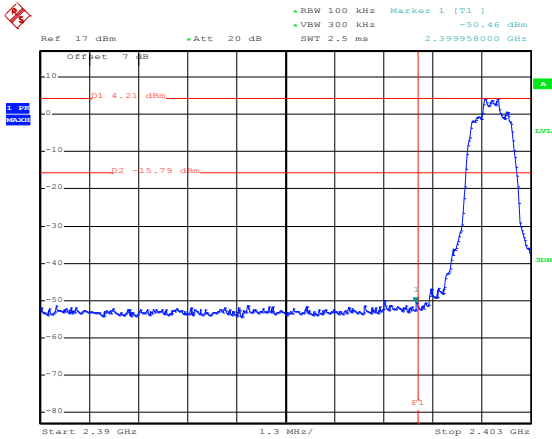

Date: 16.APR.2020 15:36:56

No-hopping mode

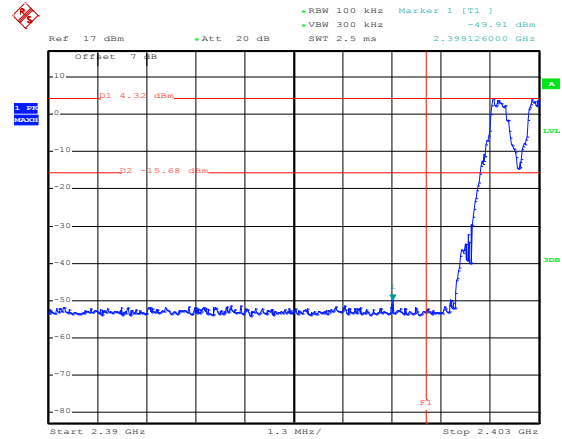

Date: 16.APR.2020 15:38:30

Hopping mode

Highest Channel

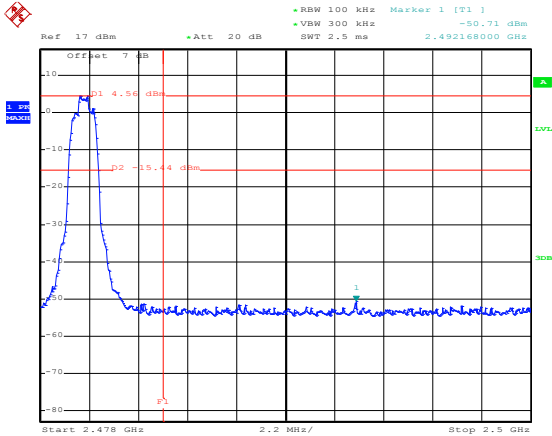

Date: 16.APR.2020 15:48:16

No-hopping mode

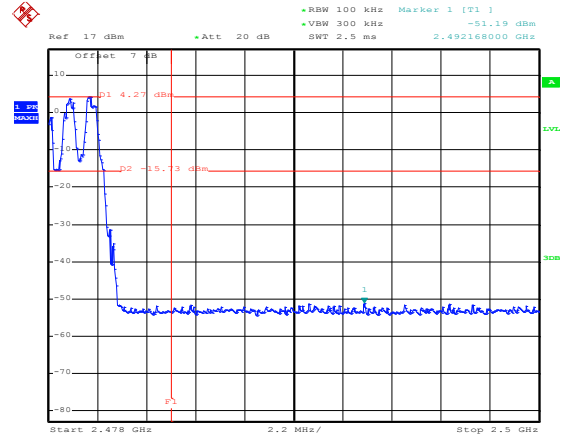

Date: 16.APR.2020 15:49:42

Hopping mode

6.8.2 Radiated Emission Method

Test Requirement:	RSS-GEN Section 8.10				
Test Frequency Range:	2310MHz to 2390MHz and 2483.5MHz to 2500MHz				
Test Distance:	3m				
Receiver setup:	Frequency	Detector	RBW	VBW	Remark
	Above 1GHz	Peak	1MHz	3MHz	Peak Value
RMS		1MHz	3MHz	Average Value	
Limit:	Frequency	Limit (dBuV/m @3m)		Remark	
	Above 1GHz	54.00		Average Value	
		74.00		Peak Value	
Test setup:					
Test Procedure:	<ol style="list-style-type: none"> 1. The EUT was placed on the top of a rotating table 1.5meters above the ground at a 3 meter camber. The table was rotated 360 degrees to determine the position of the highest radiation. 2. The EUT was set 3 meters away from the interference-receiving antenna, which was mounted on the top of a variable-height antenna tower. 3. The antenna height is varied from one meter to four meters above the ground to determine the maximum value of the field strength. Both horizontal and vertical polarizations of the antenna are set to make the measurement. 4. For each suspected emission, the EUT was arranged to its worst case and then the antenna was tuned to heights from 1 meter to 4 meters and the rota table was turned from 0 degrees to 360 degrees to find the maximum reading. 5. The test-receiver system was set to Peak Detect Function and Specified Bandwidth with Maximum Hold Mode. 6. If the emission level of the EUT in peak mode was 10dB lower than the limit specified, then testing could be stopped and the peak values of the EUT would be reported. Otherwise the emissions that did not have 10dB margin would be re-tested one by one using peak, quasi-peak or average method as specified and then reported in a data sheet. 				
Test Instruments:	Refer to section 5.9 for details				
Test mode:	Non-hopping mode				
Test results:	Passed				

Ceramic Antenna:

GFSK Mode:

Product Name:	Komikan	Product Model:	Komikan
Test By:	Mike	Test mode:	DH1 Tx mode
Test Channel:	Lowest channel	Polarization:	Vertical
Test Voltage:	AC 120/60Hz	Environment:	Temp: 24°C Humi: 57%

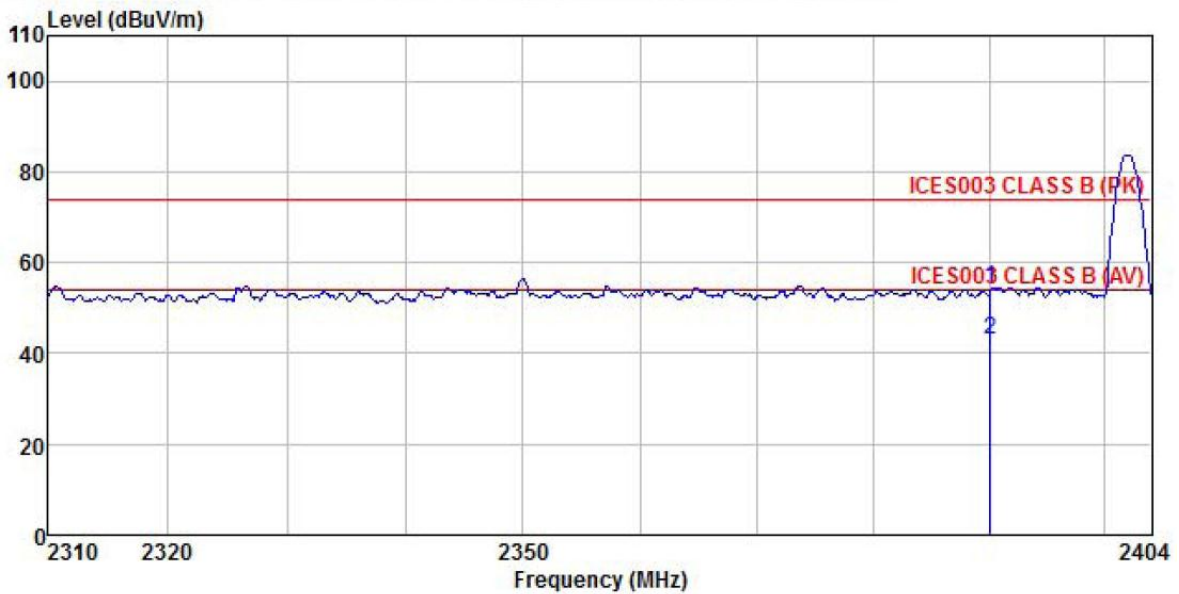

	Read	Antenna	Cable	Preamp	Limit	Over	
Freq	Level	Factor	Loss	Factor	Level	Line	Limit Remark
MHz	dBuV	dB/m	dB	dB	dBuV/m	dBuV/m	dB
1	2390.000	22.48	27.07	4.69	0.00	54.24	74.00 -19.76 Peak
2	2390.000	11.16	27.07	4.69	0.00	42.92	54.00 -11.08 Average

Remark:

1. Final Level = Receiver Read level + Antenna Factor + Cable Loss – Pre-amplifier Factor.
2. The emission levels of other frequencies are lower than the limit 20dB and not show in test report.

Product Name:	Komikan	Product Model:	Komikan
Test By:	Mike	Test mode:	DH1 Tx mode
Test Channel:	Lowest channel	Polarization:	Horizontal
Test Voltage:	AC 120/60Hz	Environment:	Temp: 24°C Huni: 57%

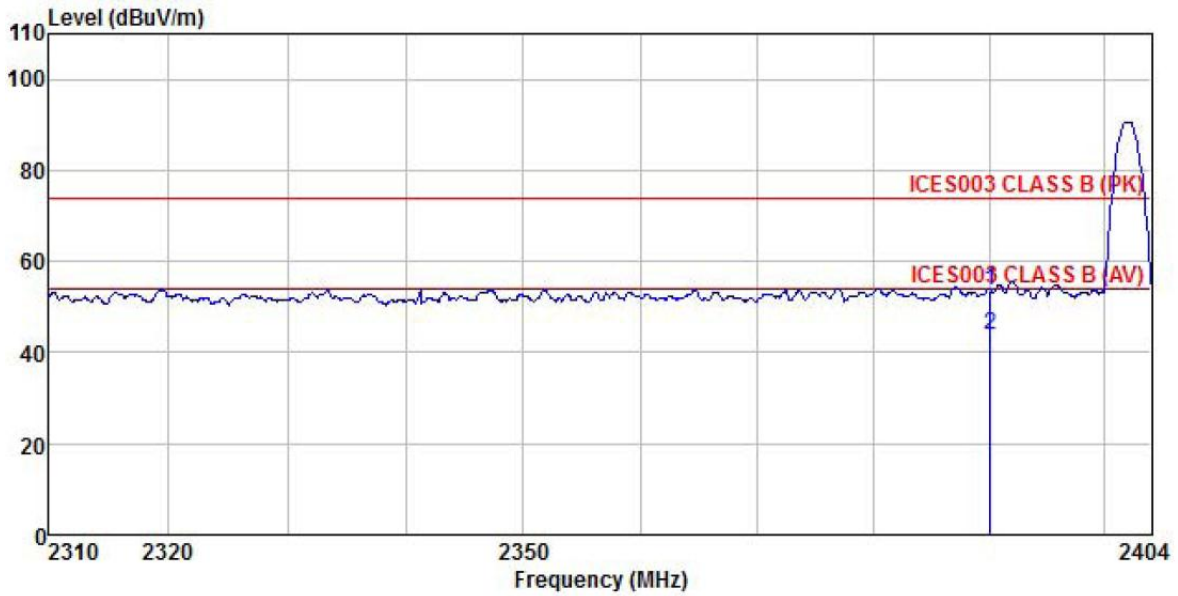

	Read	Antenna	Cable	Preamp	Level	Limit	Over	
Freq	Level	Factor	Loss	Factor	Level	Line	Limit	Remark
MHz	dBuV	dB/m	dB	dB	dBuV/m	dBuV/m	dB	
1	2390.000	21.70	27.08	4.69	0.00	53.47	74.00	-20.53 Peak
2	2390.000	12.14	27.08	4.69	0.00	43.91	54.00	-10.09 Average

Remark:

1. Final Level = Receiver Read level + Antenna Factor + Cable Loss – Preamplifier Factor.
2. The emission levels of other frequencies are lower than the limit 20dB and not show in test report.

Product Name:	Komikan	Product Model:	Komikan
Test By:	Mike	Test mode:	DH1 Tx mode
Test Channel:	Highest channel	Polarization:	Vertical
Test Voltage:	AC 120/60Hz	Environment:	Temp: 24°C Humi: 57%

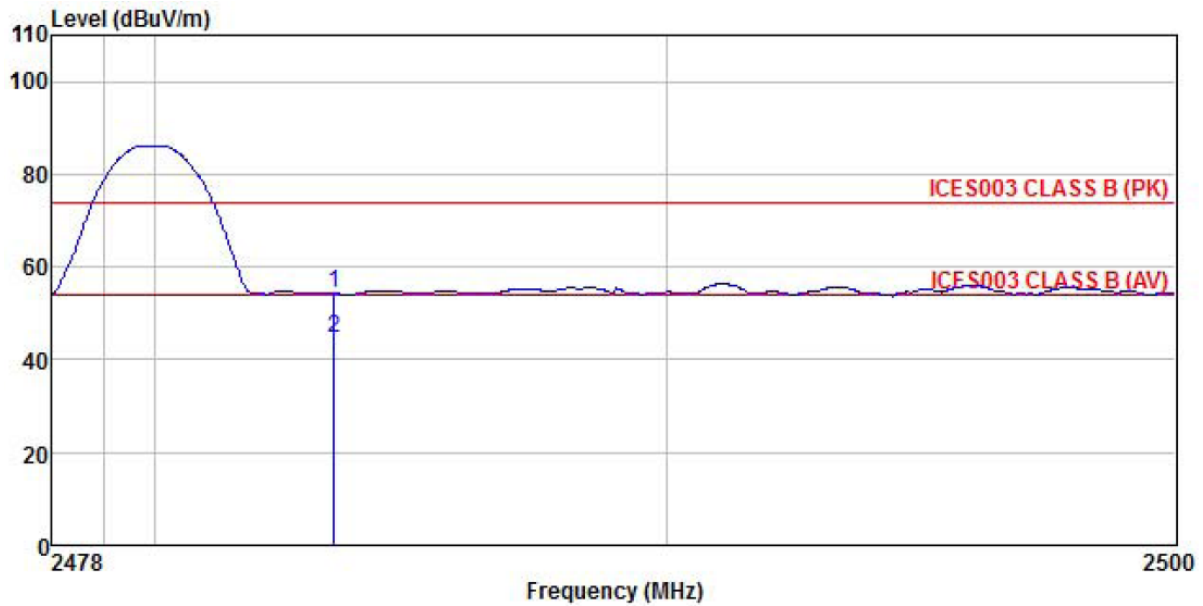

	Read	Antenna	Cable	Preamp	Level	Limit	Over	
	Freq	Level	Factor	Loss	Factor	Line	Limit	Remark
	MHz	dBuV	dB/m	dB	dB	dBuV/m	dBuV/m	dB
1	2483.500	22.27	27.36	4.81	0.00	54.44	74.00	-19.56 Peak
2	2483.500	12.40	27.36	4.81	0.00	44.57	54.00	-9.43 Average

Remark:

1. Final Level = Receiver Read level + Antenna Factor + Cable Loss – Preamplifier Factor.
2. The emission levels of other frequencies are lower than the limit 20dB and not show in test report.

Product Name:	Komikan	Product Model:	Komikan
Test By:	Mike	Test mode:	DH1 Tx mode
Test Channel:	Highest channel	Polarization:	Horizontal
Test Voltage:	AC 120/60Hz	Environment:	Temp: 24°C Huni: 57%

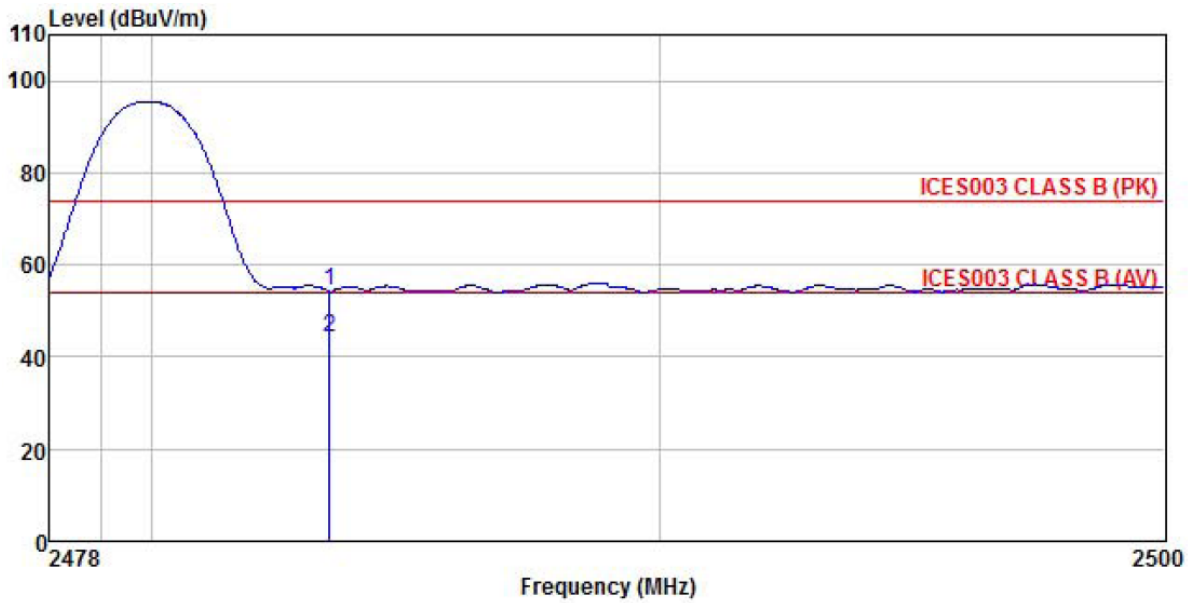

	Read	Antenna	Cable	Preamp	Level	Limit	Over	
	Freq	Level	Factor	Loss	Factor	Line	Limit	Remark
	MHz	dBuV	dB/m	dB	dB	dBuV/m	dBuV/m	dB
1	2483.500	22.06	27.35	4.81	0.00	54.22	74.00	-19.78 Peak
2	2483.500	12.08	27.35	4.81	0.00	44.24	54.00	-9.76 Average

Remark:

1. Final Level = Receiver Read level + Antenna Factor + Cable Loss – Pre-amplifier Factor.
2. The emission levels of other frequencies are lower than the limit 20dB and not show in test report.

$\pi/4$ -DQPSK mode

Product Name:	Komikan	Product Model:	Komikan
Test By:	Mike	Test mode:	2DH1 Tx mode
Test Channel:	Lowest channel	Polarization:	Vertical
Test Voltage:	AC 120/60Hz	Environment:	Temp: 24°C Humi: 57%

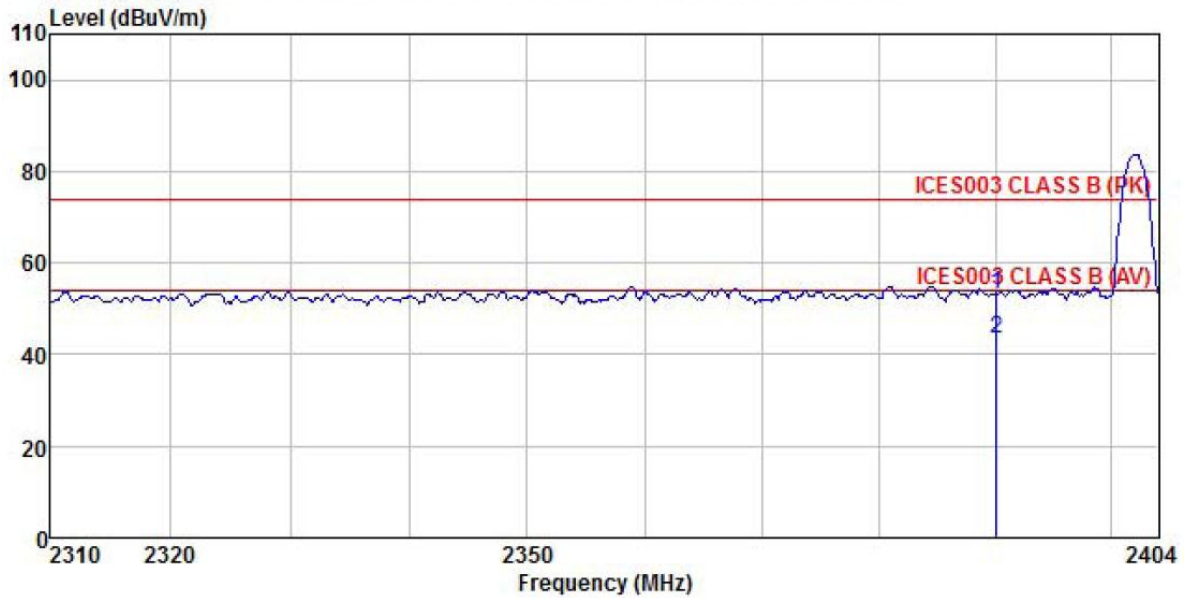

	Read	Antenna	Cable	Preamp	Limit	Over	
Freq	Level	Factor	Loss	Factor	Level	Line	Limit Remark
MHz	dBuV	dB/m	dB	dB	dBuV/m	dBuV/m	dB
1	2390.000	21.46	27.07	4.69	0.00	53.22	74.00 -20.78 Peak
2	2390.000	11.63	27.07	4.69	0.00	43.39	54.00 -10.61 Average

Remark:

1. Final Level = Receiver Read level + Antenna Factor + Cable Loss – Pre-amplifier Factor.
2. The emission levels of other frequencies are lower than the limit 20dB and not show in test report.

Product Name:	Komikan	Product Model:	Komikan
Test By:	Mike	Test mode:	2DH1 Tx mode
Test Channel:	Lowest channel	Polarization:	Horizontal
Test Voltage:	AC 120/60Hz	Environment:	Temp: 24°C Huni: 57%

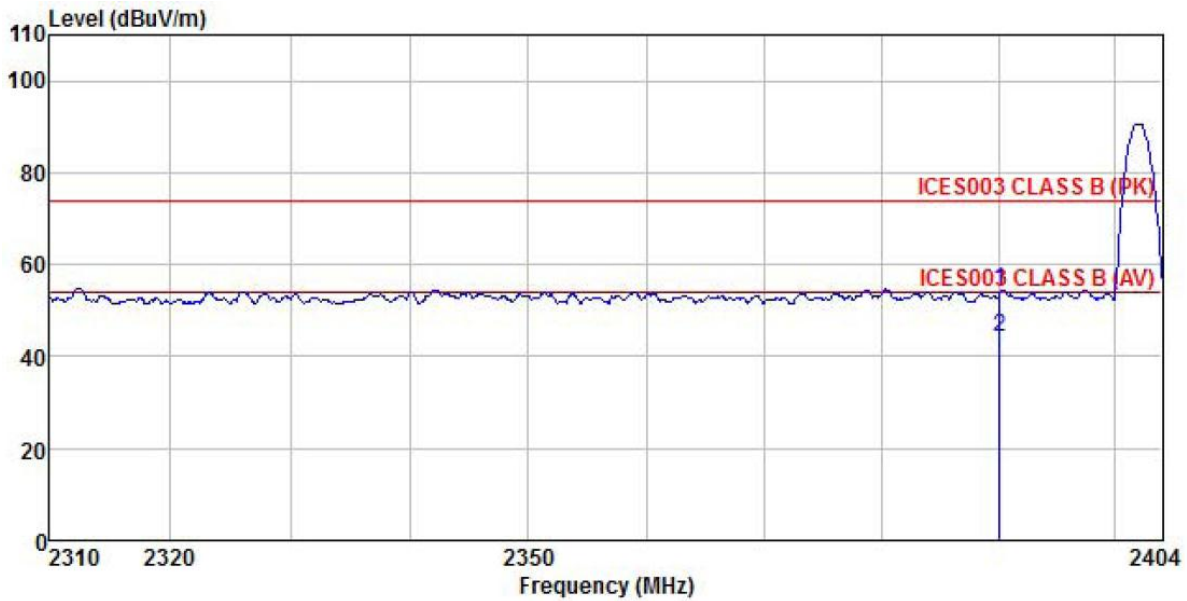

	Read	Antenna	Cable	Preamp	Limit	Over		
Freq	Level	Factor	Loss	Factor	Line	Limit	Remark	
MHz	dBuV	dB/m	dB	dB	dBuV/m	dBuV/m	dB	
1	2390.000	22.49	27.08	4.69	0.00	54.26	74.00	-19.74 Peak
2	2390.000	12.32	27.08	4.69	0.00	44.09	54.00	-9.91 Average

Remark:

1. Final Level = Receiver Read level + Antenna Factor + Cable Loss – Pre-amplifier Factor.
2. The emission levels of other frequencies are lower than the limit 20dB and not show in test report.

Product Name:	Komikan	Product Model:	Komikan
Test By:	Mike	Test mode:	2DH1 Tx mode
Test Channel:	Highest channel	Polarization:	Vertical
Test Voltage:	AC 120/60Hz	Environment:	Temp: 24°C Huni: 57%

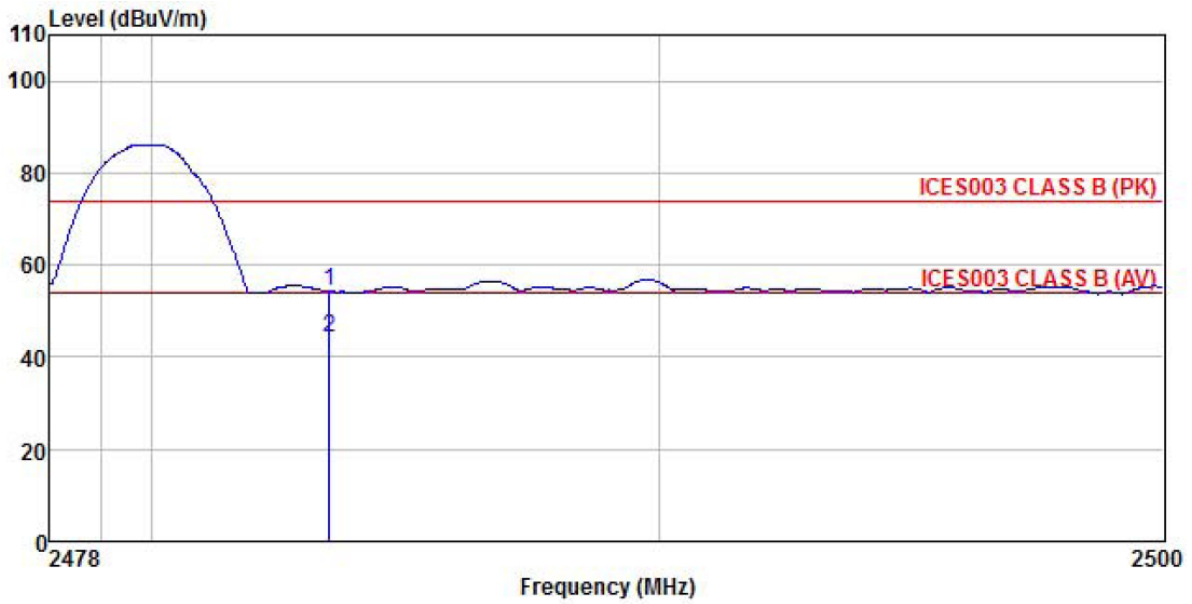

	Freq	ReadLevel	Antenna Factor	Cable Loss	Preamp Factor	Level	Limit Line	Over Limit	Remark
	MHz	dBuV	dB/m	dB	dB	dBuV/m	dBuV/m	dB	
1	2483.500	22.18	27.36	4.81	0.00	54.35	74.00	-19.65	Peak
2	2483.500	11.99	27.36	4.81	0.00	44.16	54.00	-9.84	Average

Remark:

- Final Level = Receiver Read level + Antenna Factor + Cable Loss – Pre-amplifier Factor.
- The emission levels of other frequencies are lower than the limit 20dB and not show in test report.

Product Name:	Komikan	Product Model:	Komikan
Test By:	Mike	Test mode:	2DH1 Tx mode
Test Channel:	Highest channel	Polarization:	Horizontal
Test Voltage:	AC 120/60Hz	Environment:	Temp: 24°C Huni: 57%

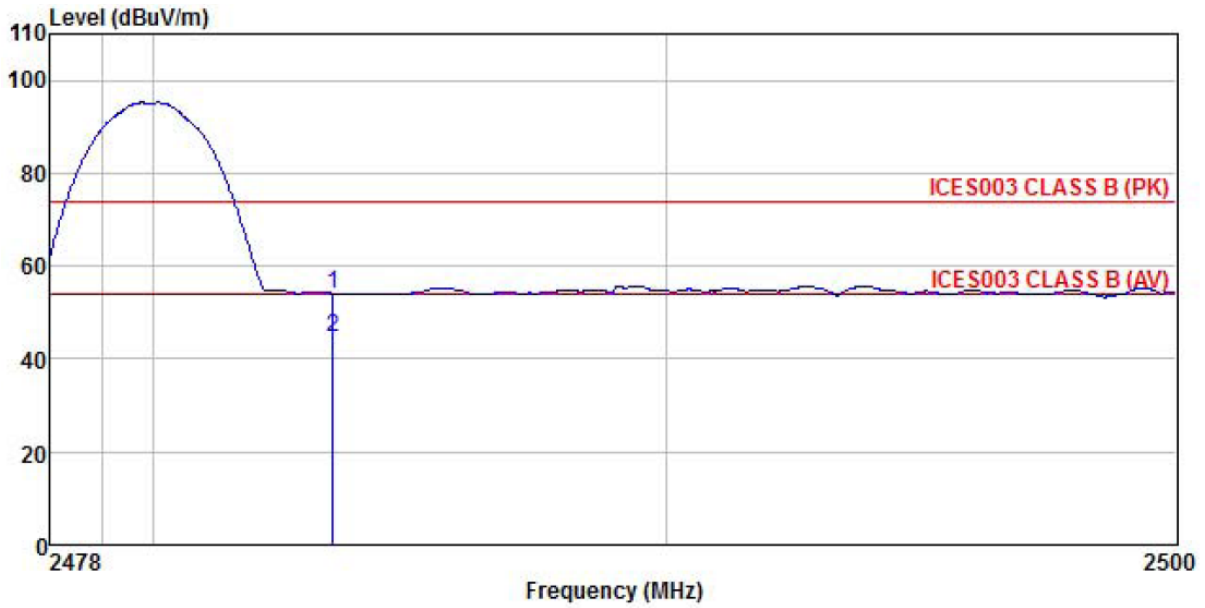

	Freq	ReadLevel	Antenna Factor	Cable Loss	Preamp Factor	Level	Limit Line	Over Limit	Remark
	MHz	dBuV	dB/m	dB	dB	dBuV/m	dBuV/m	dB	
1	2483.500	21.83	27.35	4.81	0.00	53.99	74.00	-20.01	Peak
2	2483.500	12.69	27.35	4.81	0.00	44.85	54.00	-9.15	Average

Remark:

1. Final Level = Receiver Read level + Antenna Factor + Cable Loss – Pre-amplifier Factor.
2. The emission levels of other frequencies are lower than the limit 20dB and not show in test report.

8DPSK mode

Product Name:	Komikan	Product Model:	Komikan
Test By:	Mike	Test mode:	3DH1 Tx mode
Test Channel:	Lowest channel	Polarization:	Vertical
Test Voltage:	AC 120/60Hz	Environment:	Temp: 24°C Humi: 57%

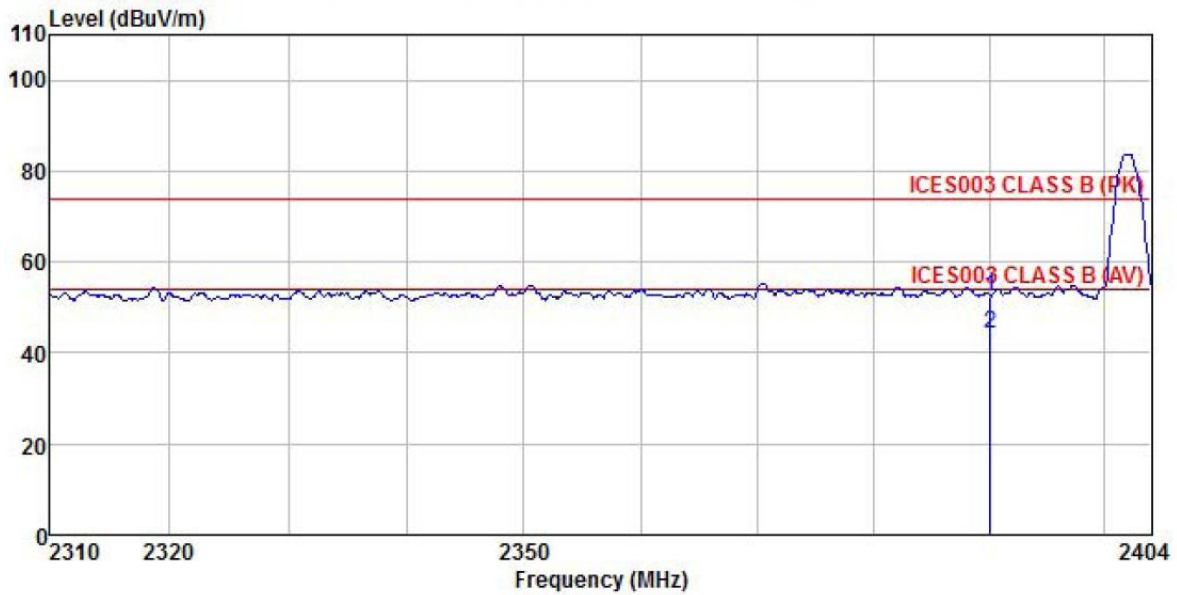

	Read Freq	Antenna Level	Antenna Factor	Cable Loss	Preamp Factor	Level	Limit Line	Over Limit	Remark
	MHz	dBuV	dB/m	dB	dB	dBuV/m	dBuV/m	dB	
1	2390.000	20.54	27.07	4.69	0.00	52.30	74.00	-21.70	Peak
2	2390.000	12.51	27.07	4.69	0.00	44.27	54.00	-9.73	Average

Remark:

- Final Level = Receiver Read level + Antenna Factor + Cable Loss – Pre-amplifier Factor.
- The emission levels of other frequencies are lower than the limit 20dB and not show in test report.

Product Name:	Komikan	Product Model:	Komikan
Test By:	Mike	Test mode:	3DH1 Tx mode
Test Channel:	Lowest channel	Polarization:	Horizontal
Test Voltage:	AC 120/60Hz	Environment:	Temp: 24°C Humi: 57%

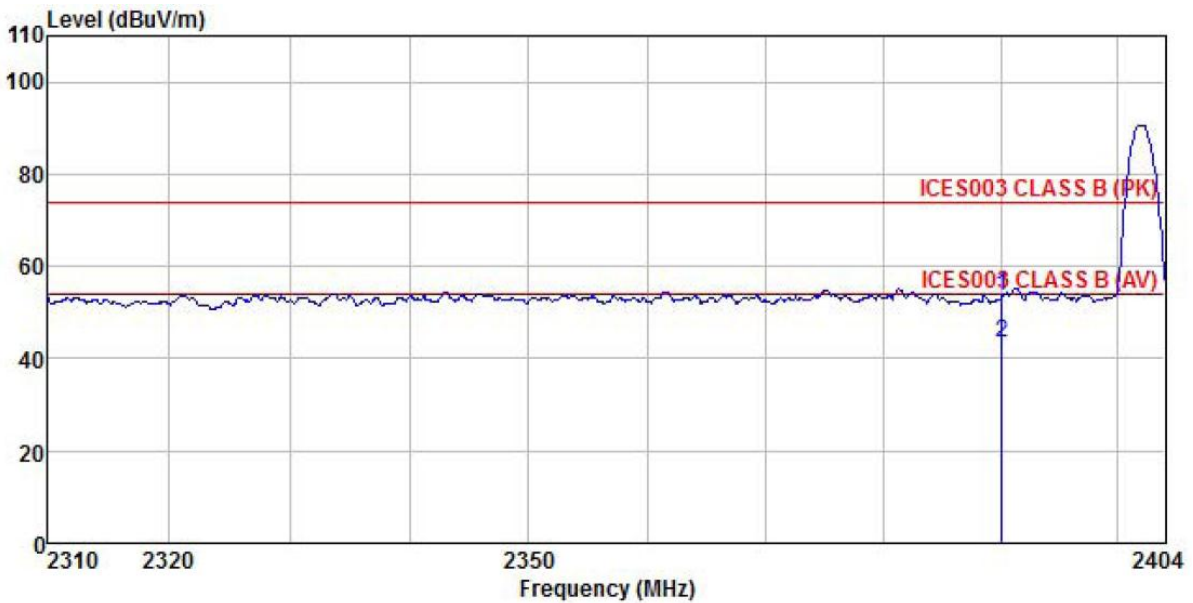

	Read	Antenna	Cable	Preamp	Limit	Over	
Freq	Level	Factor	Loss	Factor	Level	Line	Limit Remark
MHz	dBuV	dB/m	dB	dB	dBuV/m	dBuV/m	dB
1	2390.000	21.79	27.08	4.69	0.00	53.56	74.00 -20.44 Peak
2	2390.000	11.62	27.08	4.69	0.00	43.39	54.00 -10.61 Average

Remark:

1. Final Level = Receiver Read level + Antenna Factor + Cable Loss – Pre-amplifier Factor.
2. The emission levels of other frequencies are lower than the limit 20dB and not show in test report.

Product Name:	Komikan	Product Model:	Komikan
Test By:	Mike	Test mode:	3DH1 Tx mode
Test Channel:	Highest channel	Polarization:	Vertical
Test Voltage:	AC 120/60Hz	Environment:	Temp: 24°C Huni: 57%

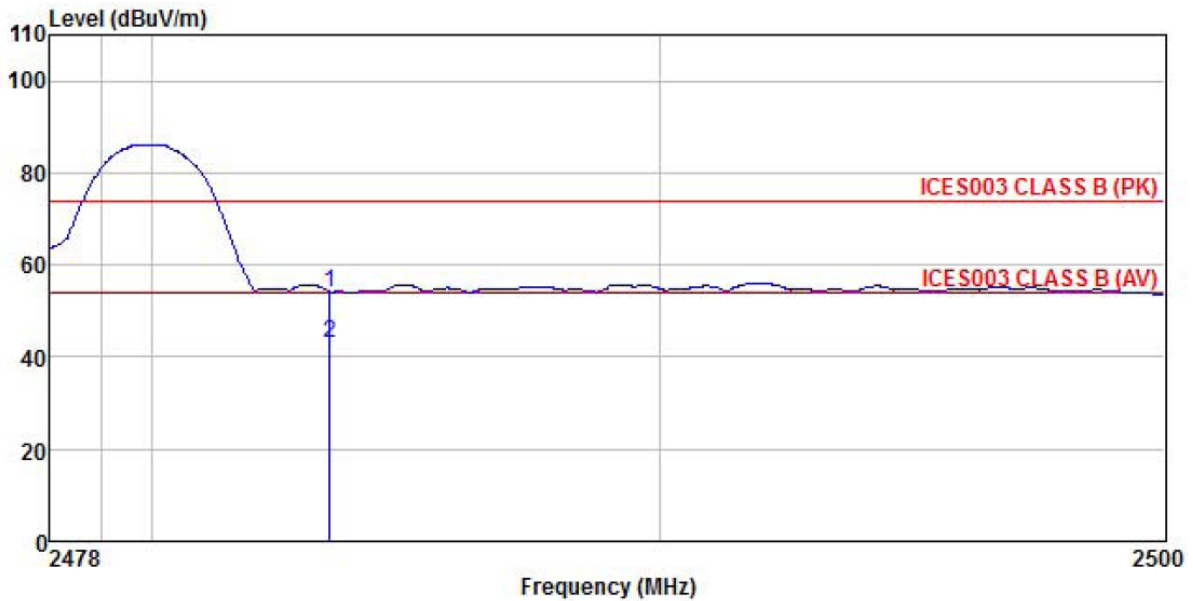

	Read	Antenna	Cable	Preamp	Limit	Over		
Freq	Level	Factor	Loss	Factor	Level	Line	Limit	
-----	-----	-----	-----	-----	-----	-----	-----	
MHz	dBuV	dB/m	dB	dB	dBuV/m	dBuV/m	dB	
1	2483.500	21.90	27.36	4.81	0.00	54.07	74.00	-19.93 Peak
2	2483.500	10.83	27.36	4.81	0.00	43.00	54.00	-11.00 Average

Remark:

1. Final Level = Receiver Read level + Antenna Factor + Cable Loss – Pre-amplifier Factor.
2. The emission levels of other frequencies are lower than the limit 20dB and not show in test report.

Product Name:	Komikan	Product Model:	Komikan
Test By:	Mike	Test mode:	3DH1 Tx mode
Test Channel:	Highest channel	Polarization:	Horizontal
Test Voltage:	AC 120/60Hz	Environment:	Temp: 24°C Huni: 57%

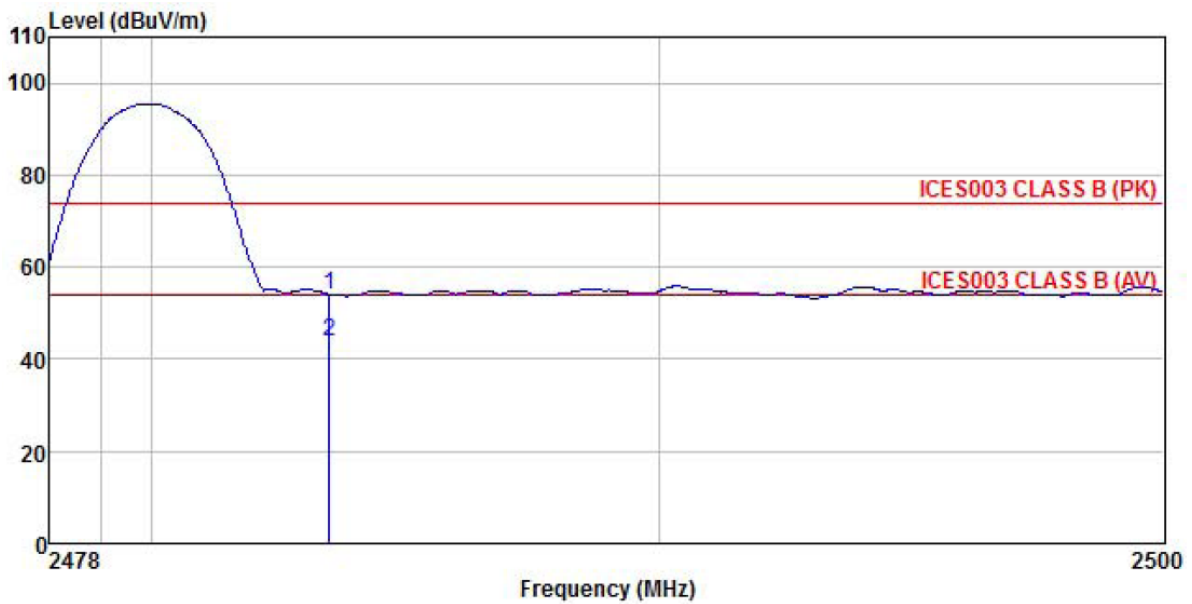

	Read Freq	Antenna Level	Antenna Factor	Cable Loss	Preamp Factor	Level	Limit Line	Over Limit	Remark
	MHz	dBuV	dB/m	dB	dB	dBuV/m	dBuV/m	dB	
1	2483.500	21.75	27.35	4.81	0.00	53.91	74.00	-20.09	Peak
2	2483.500	11.66	27.35	4.81	0.00	43.82	54.00	-10.18	Average

Remark:

1. Final Level = Receiver Read level + Antenna Factor + Cable Loss – Pre-amplifier Factor.
2. The emission levels of other frequencies are lower than the limit 20dB and not show in test report.

Flex Antenna:

GFSK Mode:

Product Name:	Komikan	Product Model:	Komikan
Test By:	Mike	Test mode:	DH1 Tx mode
Test Channel:	Lowest channel	Polarization:	Vertical
Test Voltage:	AC 120/60Hz	Environment:	Temp: 24°C Humi: 57%

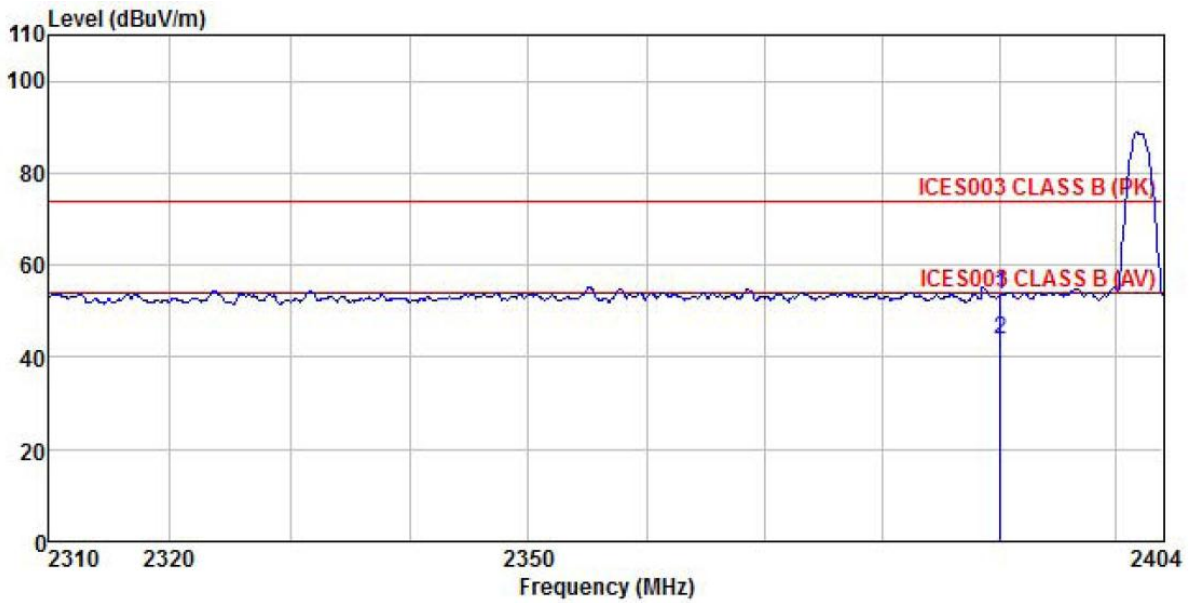

	Read	Antenna	Cable	Preamp	Limit	Over	
Freq	Level	Factor	Loss	Factor	Level	Line	Limit Remark
MHz	dBuV	dB/m	dB	dB	dBuV/m	dBuV/m	dB
1	2390.000	21.77	27.07	4.69	0.00	53.53	74.00 -20.47 Peak
2	2390.000	11.98	27.07	4.69	0.00	43.74	54.00 -10.26 Average

Remark:

1. Final Level = Receiver Read level + Antenna Factor + Cable Loss – Pre-amplifier Factor.
2. The emission levels of other frequencies are lower than the limit 20dB and not show in test report.

Product Name:	Komikan	Product Model:	Komikan
Test By:	Mike	Test mode:	DH1 Tx mode
Test Channel:	Lowest channel	Polarization:	Horizontal
Test Voltage:	AC 120/60Hz	Environment:	Temp: 24°C Humi: 57%

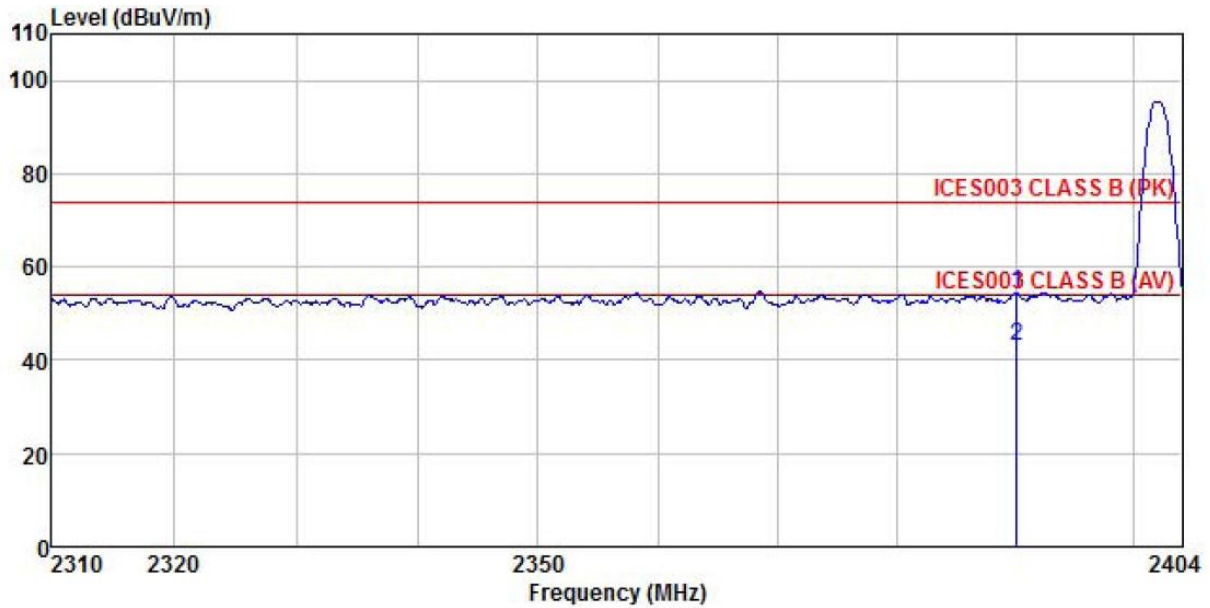

	Freq	Read Level	Antenna Factor	Cable Loss	Preamp Factor	Level	Limit Line	Over Limit	Remark
	MHz	dBuV	dB/m	dB	dB	dBuV/m	dBuV/m	dB	
1	2390.000	22.54	27.08	4.69	0.00	54.31	74.00	-19.69	Peak
2	2390.000	11.43	27.08	4.69	0.00	43.20	54.00	-10.80	Average

Remark:

1. Final Level = Receiver Read level + Antenna Factor + Cable Loss – Pre-amplifier Factor.
2. The emission levels of other frequencies are lower than the limit 20dB and not show in test report.

Product Name:	Komikan	Product Model:	Komikan
Test By:	Mike	Test mode:	DH1 Tx mode
Test Channel:	Highest channel	Polarization:	Vertical
Test Voltage:	AC 120/60Hz	Environment:	Temp: 24°C Huni: 57%

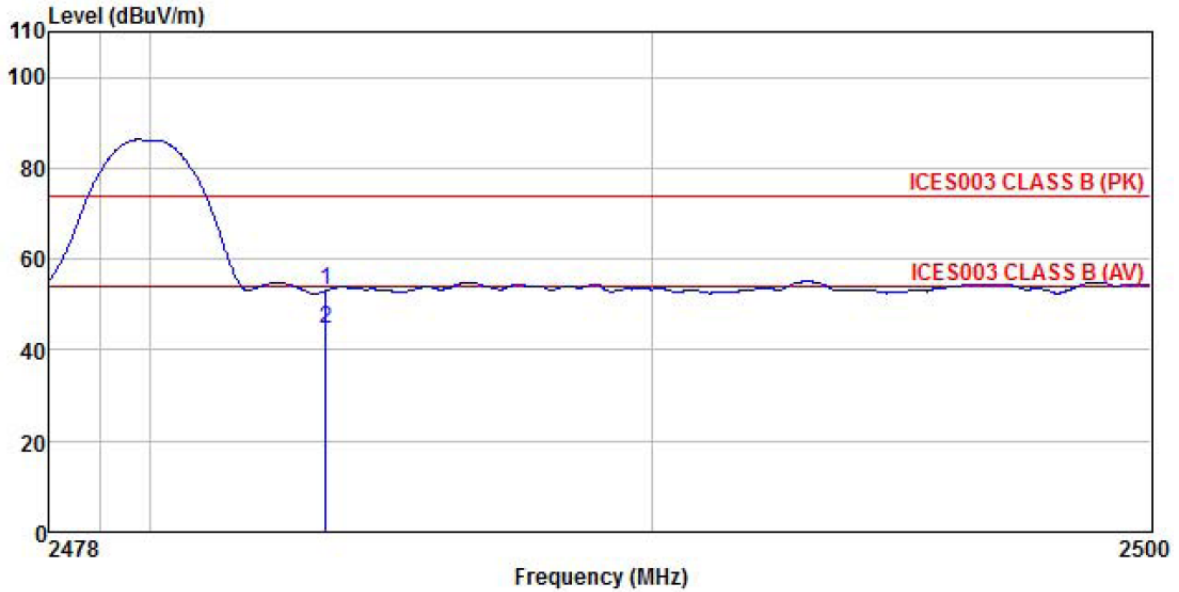

	Freq	Read Level	Antenna Factor	Cable Loss	Preamp Factor	Level	Limit Line	Over Limit	Remark
	MHz	dBuV	dB/m	dB	dB	dBuV/m	dBuV/m	dB	
1	2483.500	21.15	27.36	4.81	0.00	53.32	74.00	-20.68	Peak
2	2483.500	12.55	27.36	4.81	0.00	44.72	54.00	-9.28	Average

Remark:

1. Final Level = Receiver Read level + Antenna Factor + Cable Loss – Pre-amplifier Factor.
2. The emission levels of other frequencies are lower than the limit 20dB and not show in test report.

Product Name:	Komikan	Product Model:	Komikan
Test By:	Mike	Test mode:	DH1 Tx mode
Test Channel:	Highest channel	Polarization:	Horizontal
Test Voltage:	AC 120/60Hz	Environment:	Temp: 24°C Huni: 57%

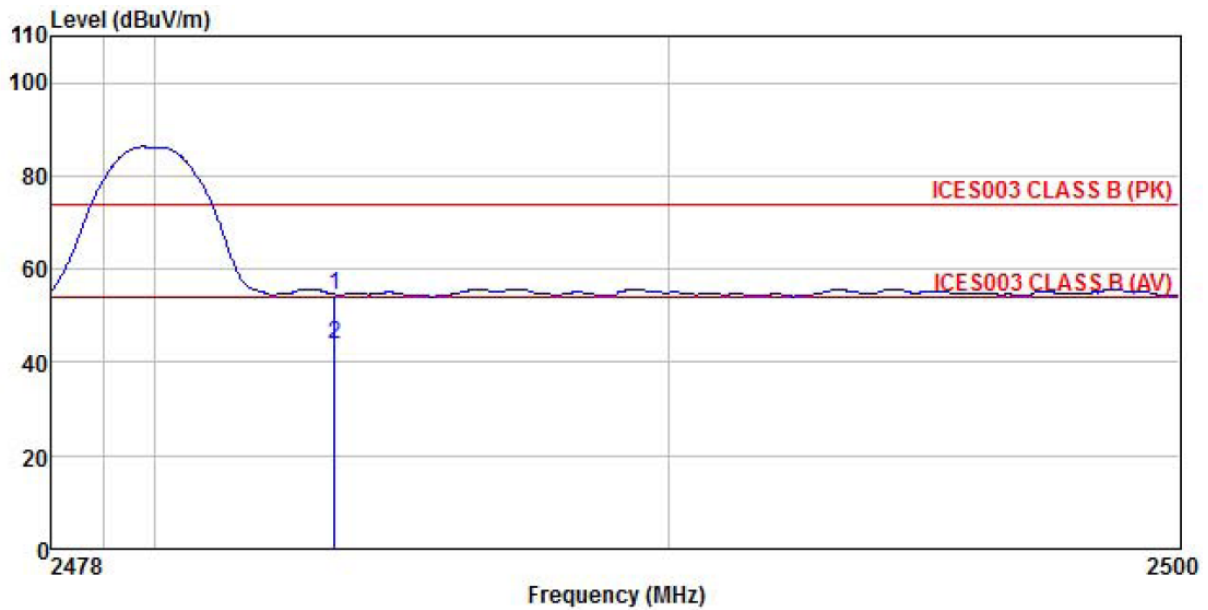

	Read Freq	Antenna Level	Antenna Factor	Cable Loss	Preamp Factor	Level	Limit Line	Over Limit	Remark
	MHz	dBuV	dB/m	dB	dB	dBuV/m	dBuV/m	dB	
1	2483.500	22.26	27.35	4.81	0.00	54.42	74.00	-19.58	Peak
2	2483.500	11.85	27.35	4.81	0.00	44.01	54.00	-9.99	Average

Remark:

1. Final Level = Receiver Read level + Antenna Factor + Cable Loss – Pre-amplifier Factor.
2. The emission levels of other frequencies are lower than the limit 20dB and not show in test report.

π/4-DQPSK mode

Product Name:	Komikan	Product Model:	Komikan
Test By:	Mike	Test mode:	2DH1 Tx mode
Test Channel:	Lowest channel	Polarization:	Vertical
Test Voltage:	AC 120/60Hz	Environment:	Temp: 24°C Huni: 57%

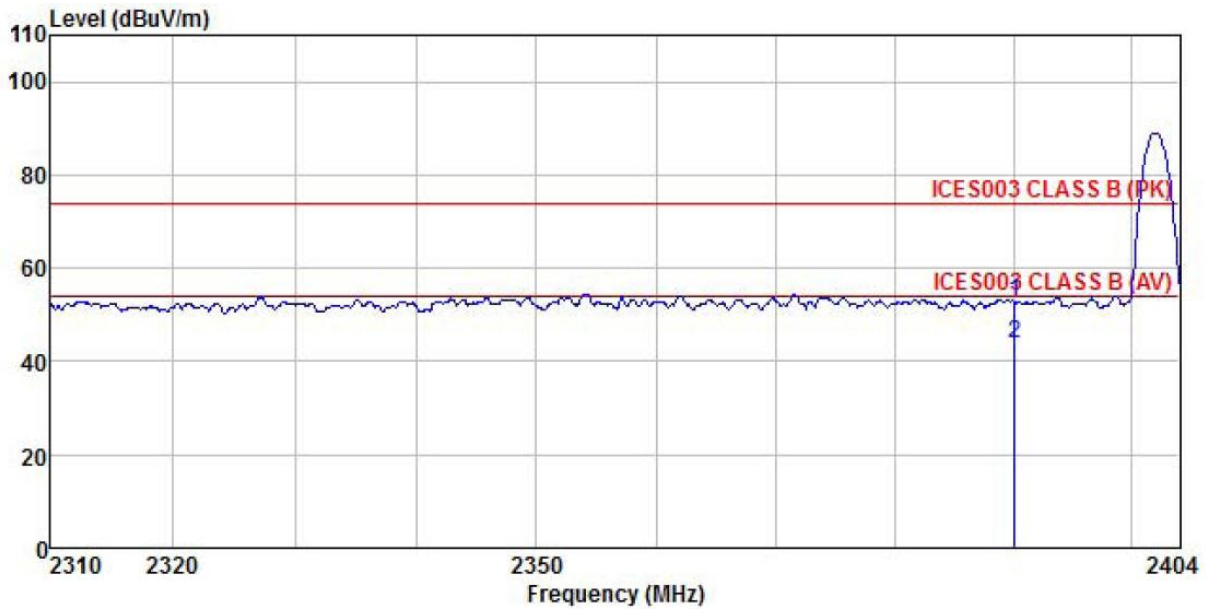

	Read Freq	Antenna Level	Antenna Factor	Cable Loss	Preamp Factor	Level	Limit Line	Over Limit	Remark
	MHz	dBuV	dB/m	dB	dB	dBuV/m	dBuV/m	dB	
1	2390.000	21.05	27.07	4.69	0.00	52.81	74.00	-21.19	Peak
2	2390.000	12.23	27.07	4.69	0.00	43.99	54.00	-10.01	Average

Remark:

1. Final Level = Receiver Read level + Antenna Factor + Cable Loss – Pre-amplifier Factor.
2. The emission levels of other frequencies are lower than the limit 20dB and not show in test report.

Product Name:	Komikan	Product Model:	Komikan
Test By:	Mike	Test mode:	2DH1 Tx mode
Test Channel:	Lowest channel	Polarization:	Horizontal
Test Voltage:	AC 120/60Hz	Environment:	Temp: 24°C Humi: 57%

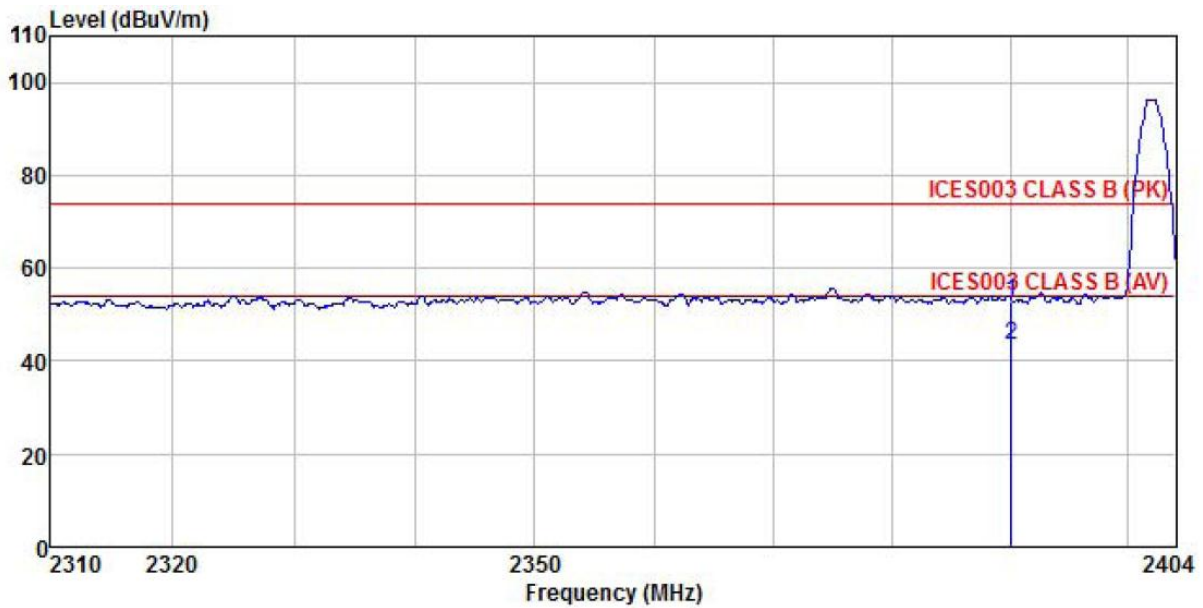

	Read Freq	Antenna Level	Antenna Factor	Cable Loss	Preamp Factor	Level	Limit Line	Over Limit	Remark
	MHz	dBuV	dB/m	dB	dB	dBuV/m	dBuV/m	dB	
1	2390.000	21.03	27.08	4.69	0.00	52.80	74.00	-21.20	Peak
2	2390.000	11.73	27.08	4.69	0.00	43.50	54.00	-10.50	Average

Remark:

1. Final Level = Receiver Read level + Antenna Factor + Cable Loss – Pre-amplifier Factor.
2. The emission levels of other frequencies are lower than the limit 20dB and not show in test report.

Product Name:	Komikan	Product Model:	Komikan
Test By:	Mike	Test mode:	2DH1 Tx mode
Test Channel:	Highest channel	Polarization:	Vertical
Test Voltage:	AC 120/60Hz	Environment:	Temp: 24°C Huni: 57%

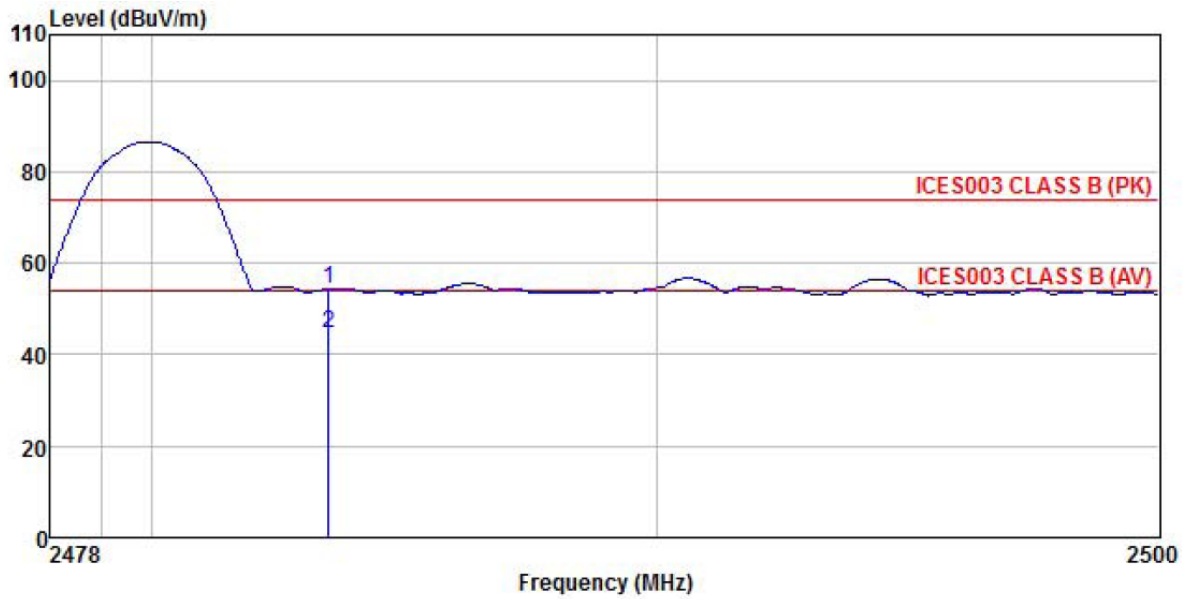

	Read	Antenna	Cable	Preamp	Limit	Over	
Freq	Level	Factor	Loss	Factor	Line	Limit	Remark
MHz	dBuV	dB/m	dB	dB	dBuV/m	dBuV/m	dB
1	2483.500	22.23	27.36	4.81	0.00	54.40	74.00 -19.60 Peak
2	2483.500	12.50	27.36	4.81	0.00	44.67	54.00 -9.33 Average

Remark:

1. Final Level = Receiver Read level + Antenna Factor + Cable Loss – Pre-amplifier Factor.
2. The emission levels of other frequencies are lower than the limit 20dB and not show in test report.

Product Name:	Komikan	Product Model:	Komikan
Test By:	Mike	Test mode:	2DH1 Tx mode
Test Channel:	Highest channel	Polarization:	Horizontal
Test Voltage:	AC 120/60Hz	Environment:	Temp: 24°C Huni: 57%

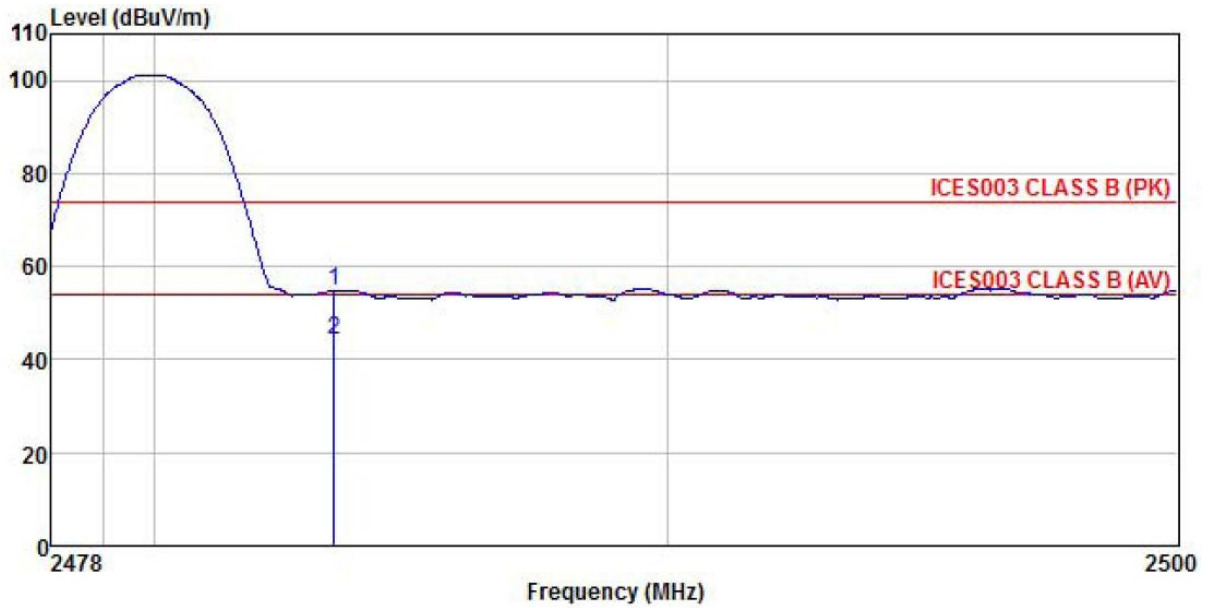

	Freq	ReadAntenna	Cable Preamp	Level	Limit	Over	Remark
	MHz	Level	Loss	Level	Line	Limit	
		dBuV	dB	dB	dBuV/m	dBuV/m	dB
1	2483.500	22.72	27.35	4.81	0.00	54.88	74.00 -19.12 Peak
2	2483.500	12.03	27.35	4.81	0.00	44.19	54.00 -9.81 Average

Remark:

- Final Level = Receiver Read level + Antenna Factor + Cable Loss – Preamplifier Factor.
- The emission levels of other frequencies are lower than the limit 20dB and not show in test report.

8DPSK mode

Product Name:	Komikan	Product Model:	Komikan
Test By:	Mike	Test mode:	3DH1 Tx mode
Test Channel:	Lowest channel	Polarization:	Vertical
Test Voltage:	AC 120/60Hz	Environment:	Temp: 24°C Humi: 57%

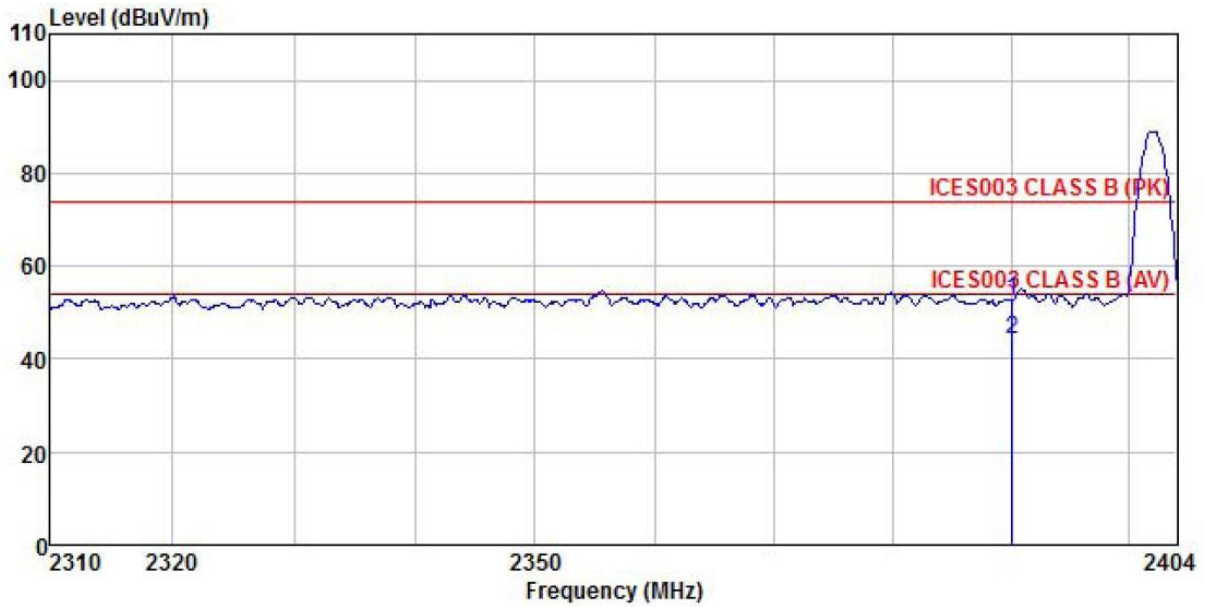

	Read Freq	Antenna Level	Antenna Factor	Cable Loss	Preamp Factor	Level	Limit	Over	Remark
	MHz	dBuV	dB/m	dB	dB	dBuV/m	dBuV/m	dB	
1	2390.000	20.88	27.07	4.69	0.00	52.64	74.00	-21.36	Peak
2	2390.000	12.50	27.07	4.69	0.00	44.26	54.00	-9.74	Average

Remark:

- Final Level = Receiver Read level + Antenna Factor + Cable Loss – Pre-amplifier Factor.
- The emission levels of other frequencies are lower than the limit 20dB and not show in test report.

Product Name:	Komikan	Product Model:	Komikan
Test By:	Mike	Test mode:	3DH1 Tx mode
Test Channel:	Lowest channel	Polarization:	Horizontal
Test Voltage:	AC 120/60Hz	Environment:	Temp: 24°C Humi: 57%

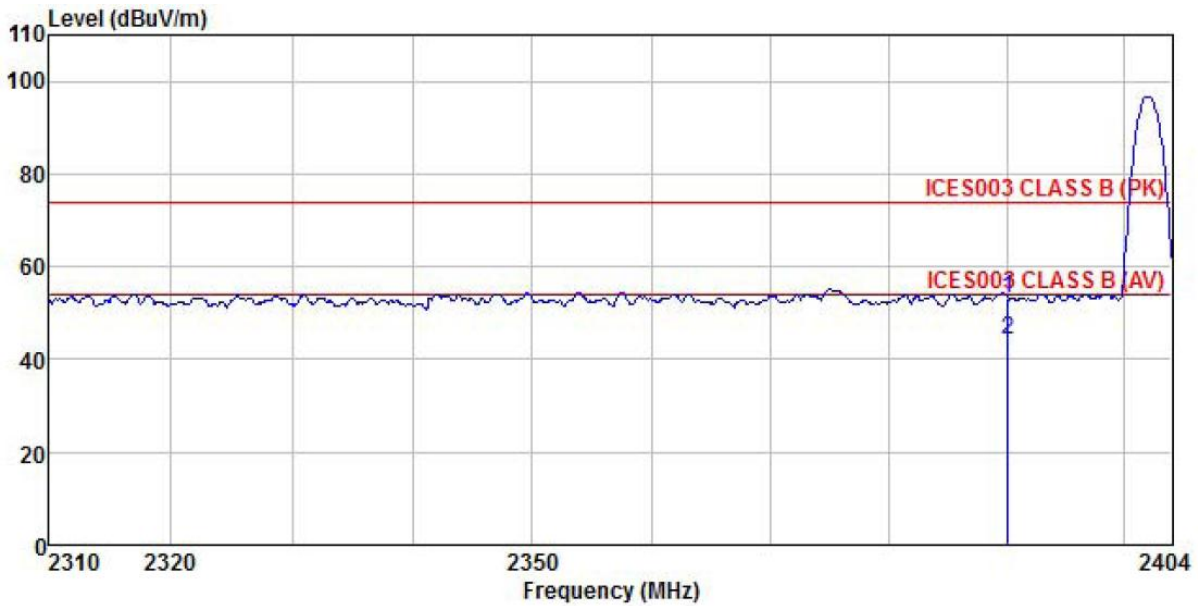

	Read	Antenna	Cable	Preamp	Limit	Over		
Freq	Level	Factor	Loss	Factor	Level	Line	Limit	
MHz	dBuV	dB/m	dB	dB	dBuV/m	dBuV/m	dB	
1	2390.000	21.30	27.08	4.69	0.00	53.07	74.00	-20.93 Peak
2	2390.000	12.32	27.08	4.69	0.00	44.09	54.00	-9.91 Average

Remark:

1. Final Level = Receiver Read level + Antenna Factor + Cable Loss – Preamplifier Factor.
2. The emission levels of other frequencies are lower than the limit 20dB and not show in test report.

Product Name:	Komikan	Product Model:	Komikan
Test By:	Mike	Test mode:	3DH1 Tx mode
Test Channel:	Highest channel	Polarization:	Vertical
Test Voltage:	AC 120/60Hz	Environment:	Temp: 24°C Huni: 57%

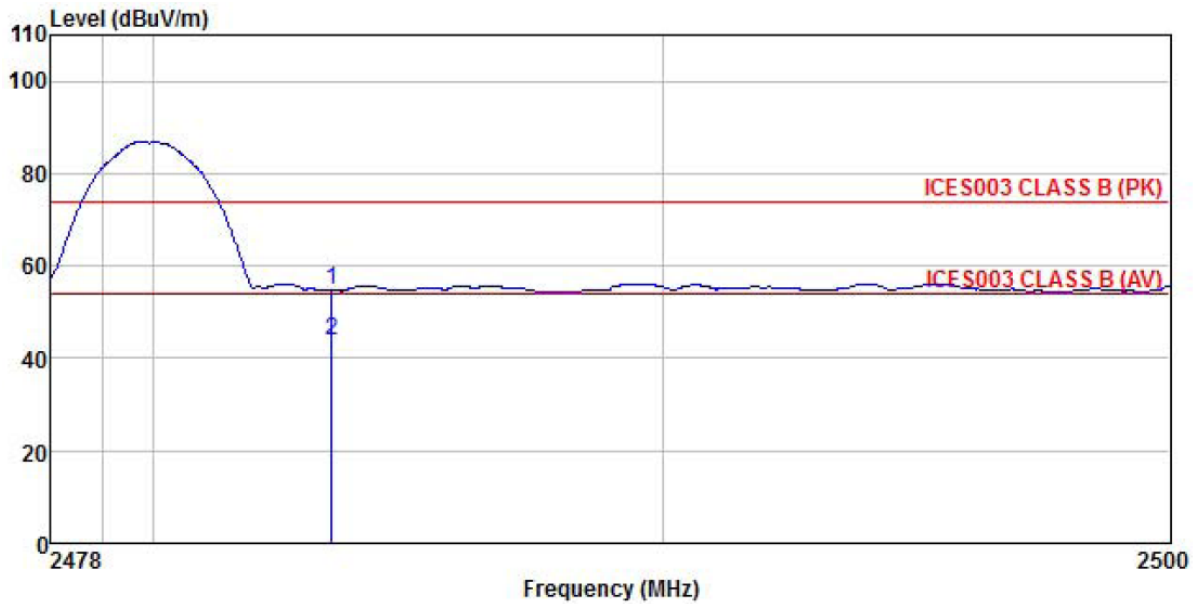

	Read	Antenna	Cable	Preamp	Limit	Over	
Freq	Level	Factor	Loss	Factor	Level	Line	Limit Remark
MHz	dBuV	dB/m	dB	dB	dBuV/m	dBuV/m	dB
1	2483.500	22.54	27.36	4.81	0.00	54.71	74.00 -19.29 Peak
2	2483.500	11.82	27.36	4.81	0.00	43.99	54.00 -10.01 Average

Remark:

1. Final Level = Receiver Read level + Antenna Factor + Cable Loss – Pre-amplifier Factor.
2. The emission levels of other frequencies are lower than the limit 20dB and not show in test report.

Product Name:	Komikan	Product Model:	Komikan
Test By:	Mike	Test mode:	3DH1 Tx mode
Test Channel:	Highest channel	Polarization:	Horizontal
Test Voltage:	AC 120/60Hz	Environment:	Temp: 24°C Humi: 57%

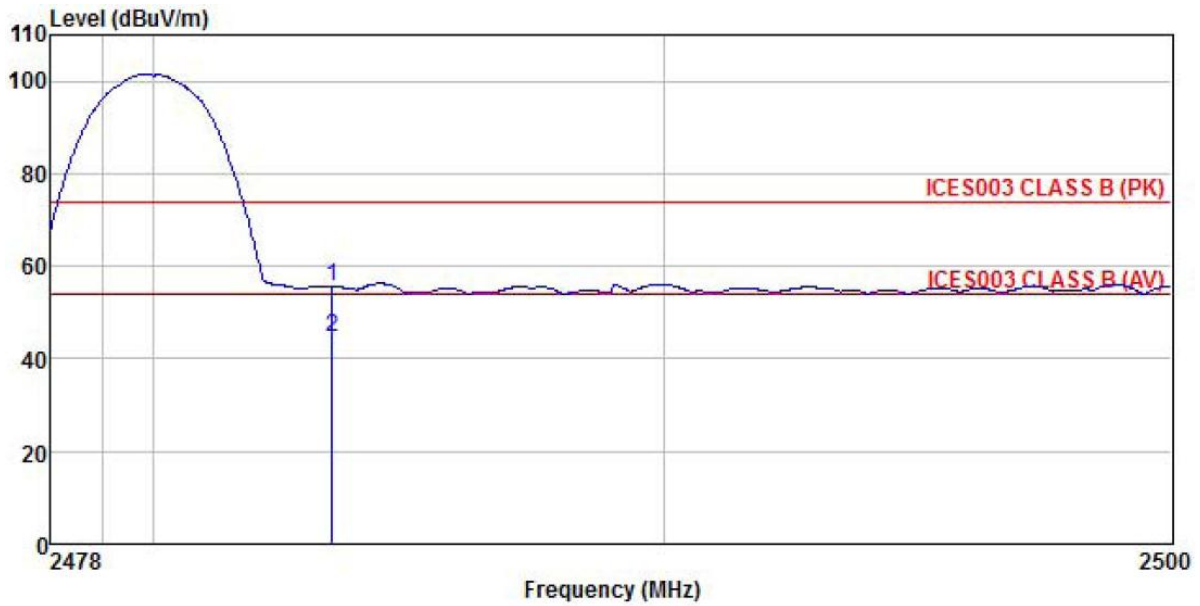

	Freq	ReadAntenna Level	Antenna Factor	Cable Loss	Preamp Factor	Level	Limit Line	Over Limit	Remark
	MHz	dBuV	dB/m	dB	dB	dBuV/m	dBuV/m	dB	
1	2483.500	23.40	27.35	4.81	0.00	55.56	74.00	-18.44	Peak
2	2483.500	12.29	27.35	4.81	0.00	44.45	54.00	-9.55	Average

Remark:

- Final Level = Receiver Read level + Antenna Factor + Cable Loss – Pre-amplifier Factor.
- The emission levels of other frequencies are lower than the limit 20dB and not show in test report.

Whip Antenna:

GFSK Mode:

Product Name:	Komikan	Product Model:	Komikan
Test By:	Mike	Test mode:	DH1 Tx mode
Test Channel:	Lowest channel	Polarization:	Vertical
Test Voltage:	AC 120/60Hz	Environment:	Temp: 24°C Humi: 57%

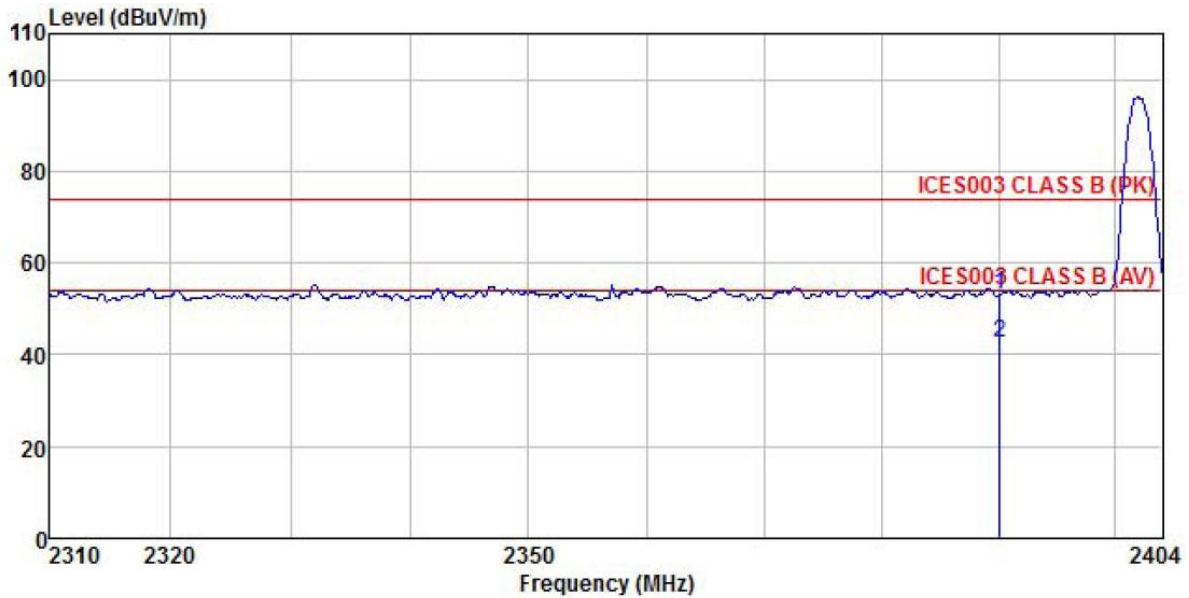

	Read	Antenna	Cable	Preamp	Limit	Over	
Freq	Level	Factor	Loss	Factor	Line	Limit	Remark
MHz	dBuV	dB/m	dB	dB	dBuV/m	dBuV/m	dB
1	2390.000	21.33	27.07	4.69	0.00	53.09	74.00 -20.91 Peak
2	2390.000	10.96	27.07	4.69	0.00	42.72	54.00 -11.28 Average

Remark:

1. Final Level = Receiver Read level + Antenna Factor + Cable Loss – Pre-amplifier Factor.
2. The emission levels of other frequencies are lower than the limit 20dB and not show in test report.

Product Name:	Komikan	Product Model:	Komikan
Test By:	Mike	Test mode:	DH1 Tx mode
Test Channel:	Lowest channel	Polarization:	Horizontal
Test Voltage:	AC 120/60Hz	Environment:	Temp: 24°C Huni: 57%

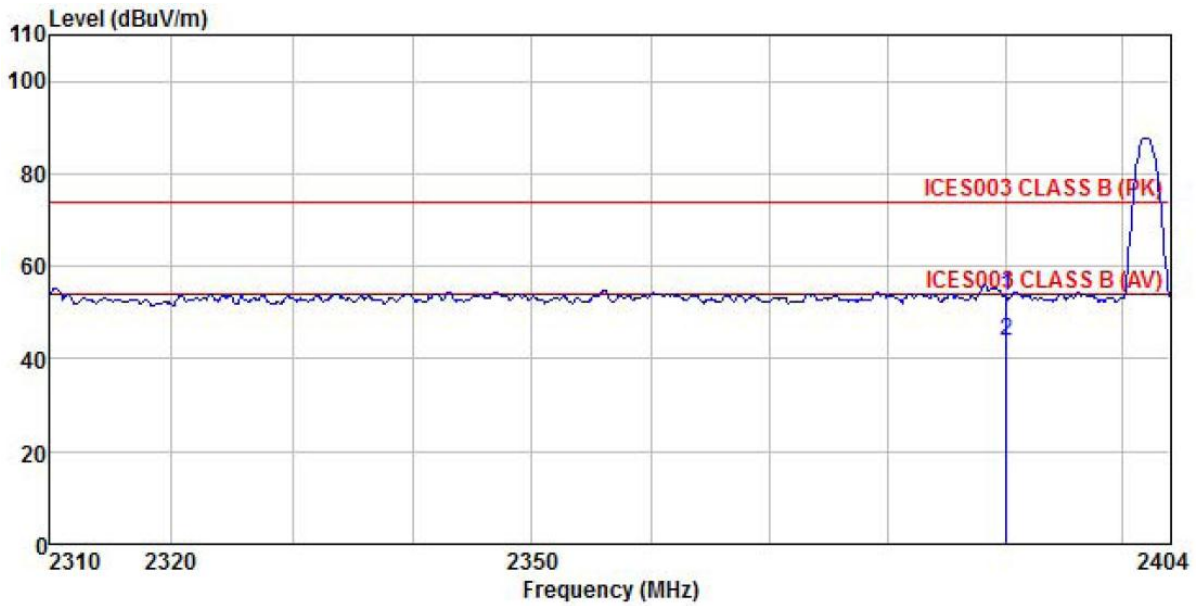

	Read	Antenna	Cable	Preamp	Limit	Over	
Freq	Level	Factor	Loss	Factor	Level	Line	Limit Remark
MHz	dBuV	dB/m	dB	dB	dBuV/m	dBuV/m	dB
1	2390.000	21.94	27.08	4.69	0.00	53.71	74.00 -20.29 Peak
2	2390.000	12.15	27.08	4.69	0.00	43.92	54.00 -10.08 Average

Remark:

1. Final Level = Receiver Read level + Antenna Factor + Cable Loss – Preamplifier Factor.
2. The emission levels of other frequencies are lower than the limit 20dB and not show in test report.

Product Name:	Komikan	Product Model:	Komikan
Test By:	Mike	Test mode:	DH1 Tx mode
Test Channel:	Highest channel	Polarization:	Vertical
Test Voltage:	AC 120/60Hz	Environment:	Temp: 24°C Huni: 57%

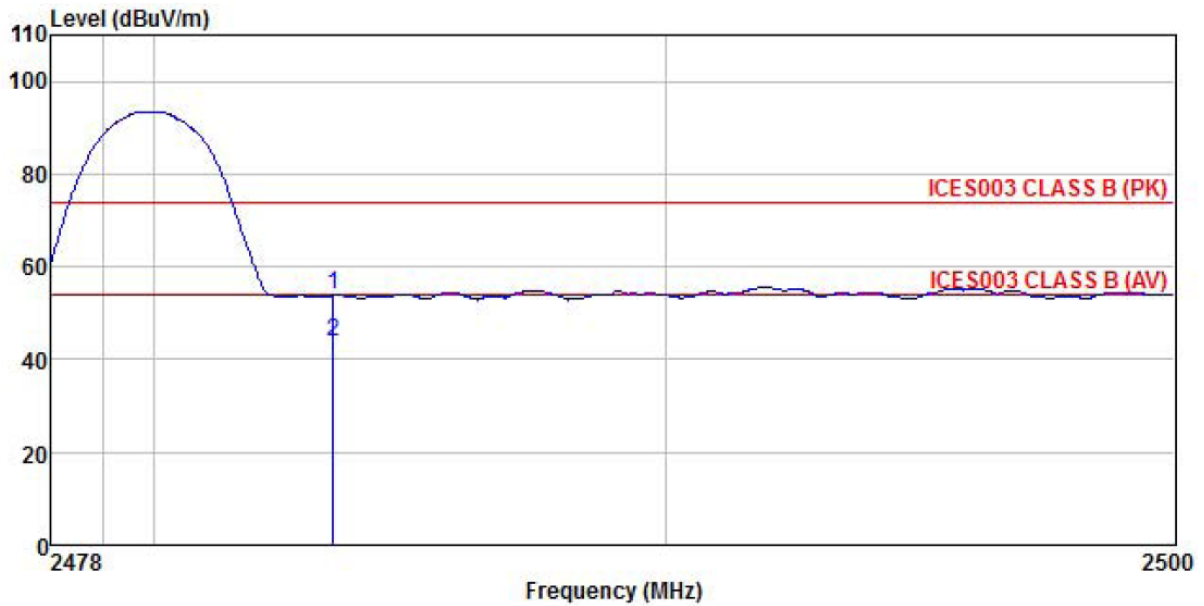

	Read	Antenna	Cable	Preamp	Level	Limit	Over		
	Level	Factor	Loss	Factor	Line	Line	Limit	Remark	
	MHz	dBuV	dB/m	dB	dB	dBuV/m	dBuV/m	dB	
1	2483.500	21.71	27.36	4.81	0.00	53.88	74.00	-20.12	Peak
2	2483.500	11.83	27.36	4.81	0.00	44.00	54.00	-10.00	Average

Remark:

1. Final Level = Receiver Read level + Antenna Factor + Cable Loss – Pre-amplifier Factor.
2. The emission levels of other frequencies are lower than the limit 20dB and not show in test report.

Product Name:	Komikan	Product Model:	Komikan
Test By:	Mike	Test mode:	DH1 Tx mode
Test Channel:	Highest channel	Polarization:	Horizontal
Test Voltage:	AC 120/60Hz	Environment:	Temp: 24°C Humi: 57%

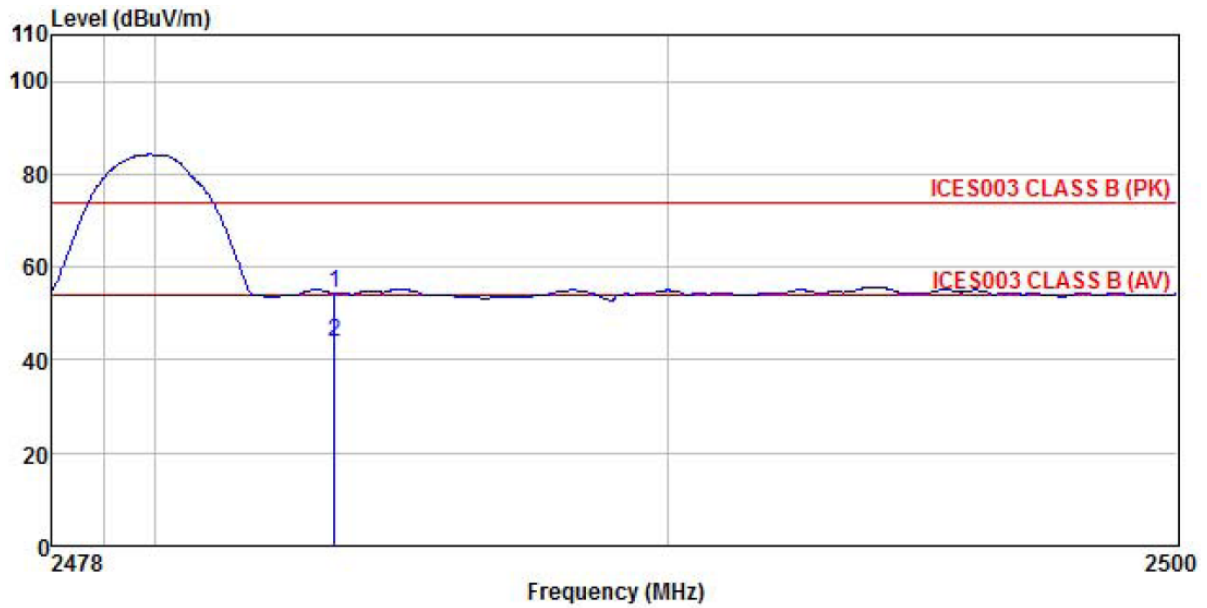

	Read	Antenna	Cable	Preamp	Level	Limit	Over	
Freq	Level	Factor	Loss	Factor	Level	Line	Limit	Remark
MHz	dBuV	dB/m	dB	dB	dBuV/m	dBuV/m	dB	
1	2483.500	22.33	27.35	4.81	0.00	54.49	74.00	-19.51 Peak
2	2483.500	11.78	27.35	4.81	0.00	43.94	54.00	-10.06 Average

Remark:

1. Final Level = Receiver Read level + Antenna Factor + Cable Loss – Pre-amplifier Factor.
2. The emission levels of other frequencies are lower than the limit 20dB and not show in test report.

π/4-DQPSK mode

Product Name:	Komikan	Product Model:	Komikan
Test By:	Mike	Test mode:	2DH1 Tx mode
Test Channel:	Lowest channel	Polarization:	Vertical
Test Voltage:	AC 120/60Hz	Environment:	Temp: 24°C Huni: 57%

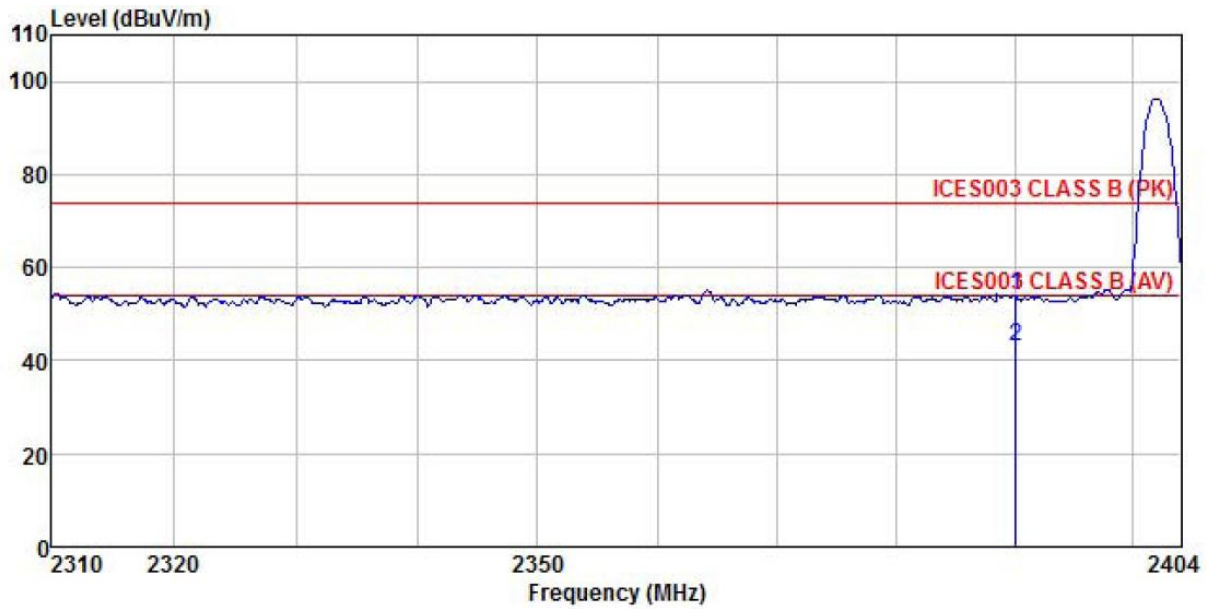

	Read Freq	Antenna Level	Antenna Factor	Cable Loss	Preamp Factor	Level	Limit	Over Limit	Remark
	MHz	dBuV	dB/m	dB	dB	dBuV/m	dBuV/m	dB	
1	2390.000	22.34	27.07	4.69	0.00	54.10	74.00	-19.90	Peak
2	2390.000	11.34	27.07	4.69	0.00	43.10	54.00	-10.90	Average

Remark:

1. Final Level = Receiver Read level + Antenna Factor + Cable Loss – Pre-amplifier Factor.
2. The emission levels of other frequencies are lower than the limit 20dB and not show in test report.

Product Name:	Komikan	Product Model:	Komikan
Test By:	Mike	Test mode:	2DH1 Tx mode
Test Channel:	Lowest channel	Polarization:	Horizontal
Test Voltage:	AC 120/60Hz	Environment:	Temp: 24°C Huni: 57%

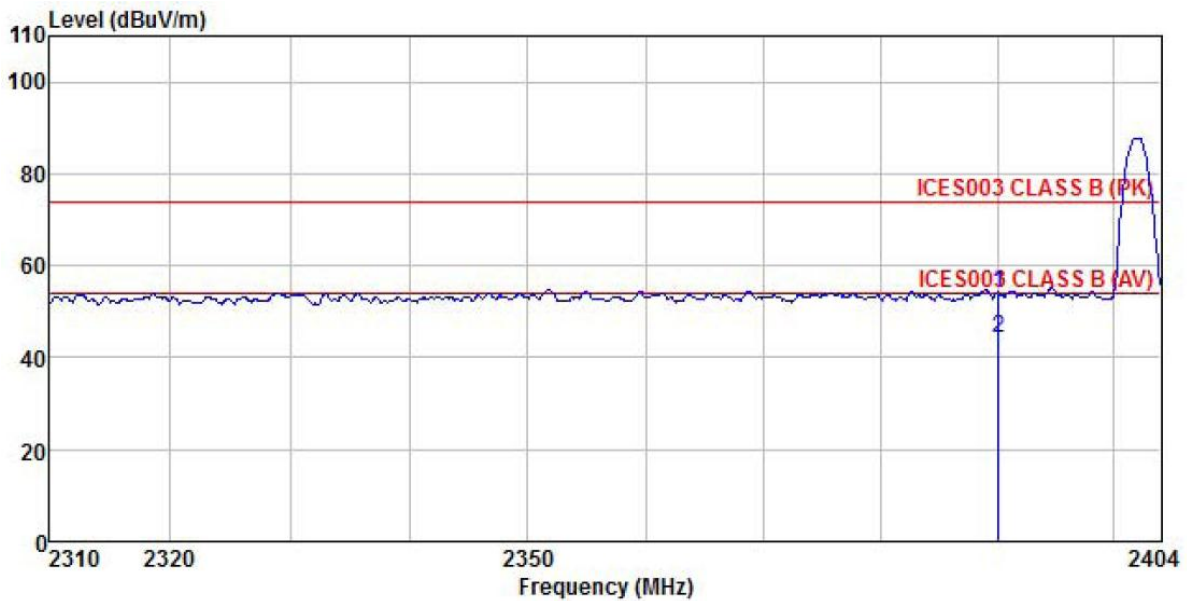

	Read Freq	Antenna Level	Antenna Factor	Cable Loss	Preamp Factor	Level	Limit Line	Over Limit	Remark
	MHz	dBuV	dB/m	dB	dB	dBuV/m	dBuV/m	dB	
1	2390.000	22.08	27.08	4.69	0.00	53.85	74.00	-20.15	Peak
2	2390.000	12.46	27.08	4.69	0.00	44.23	54.00	-9.77	Average

Remark:

1. Final Level = Receiver Read level + Antenna Factor + Cable Loss – Pre-amplifier Factor.
2. The emission levels of other frequencies are lower than the limit 20dB and not show in test report.

Product Name:	Komikan	Product Model:	Komikan
Test By:	Mike	Test mode:	2DH1 Tx mode
Test Channel:	Highest channel	Polarization:	Vertical
Test Voltage:	AC 120/60Hz	Environment:	Temp: 24°C Huni: 57%

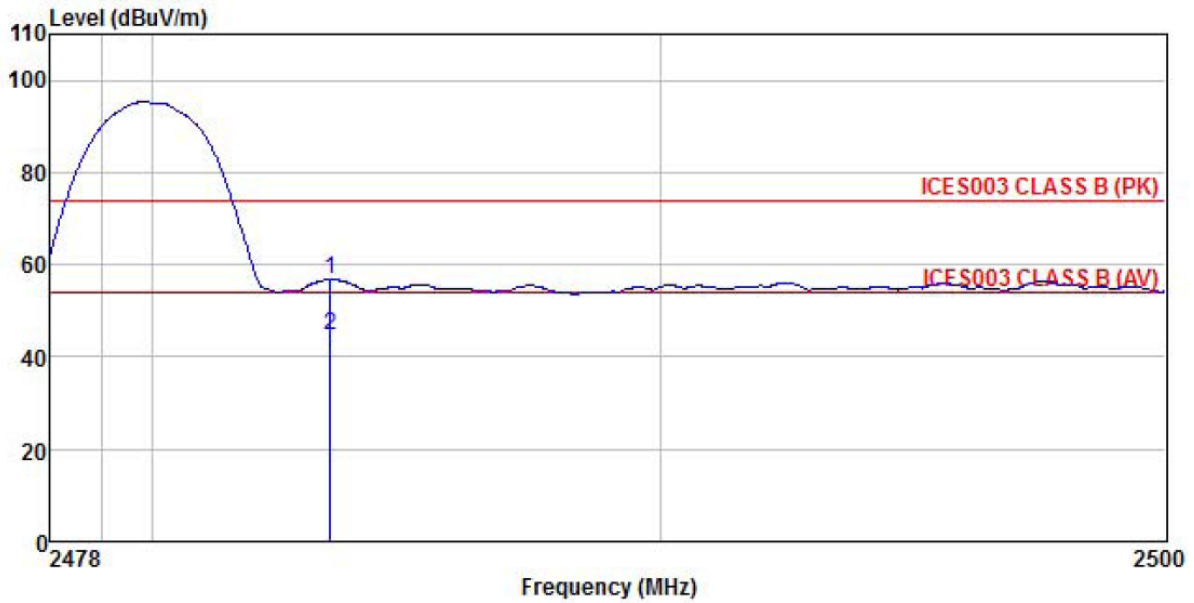

	Read	Antenna	Cable	Preamp	Limit	Over	
Freq	Level	Factor	Loss	Factor	Line	Limit	Remark
MHz	dBuV	dB/m	dB	dB	dBuV/m	dBuV/m	dB
1	2483.500	24.58	27.36	4.81	0.00	56.75	74.00 -17.25 Peak
2	2483.500	12.46	27.36	4.81	0.00	44.63	54.00 -9.37 Average

Remark:

1. Final Level = Receiver Read level + Antenna Factor + Cable Loss – Preamp Factor.
2. The emission levels of other frequencies are lower than the limit 20dB and not show in test report.

Product Name:	Komikan	Product Model:	Komikan
Test By:	Mike	Test mode:	2DH1 Tx mode
Test Channel:	Highest channel	Polarization:	Horizontal
Test Voltage:	AC 120/60Hz	Environment:	Temp: 24°C Huni: 57%

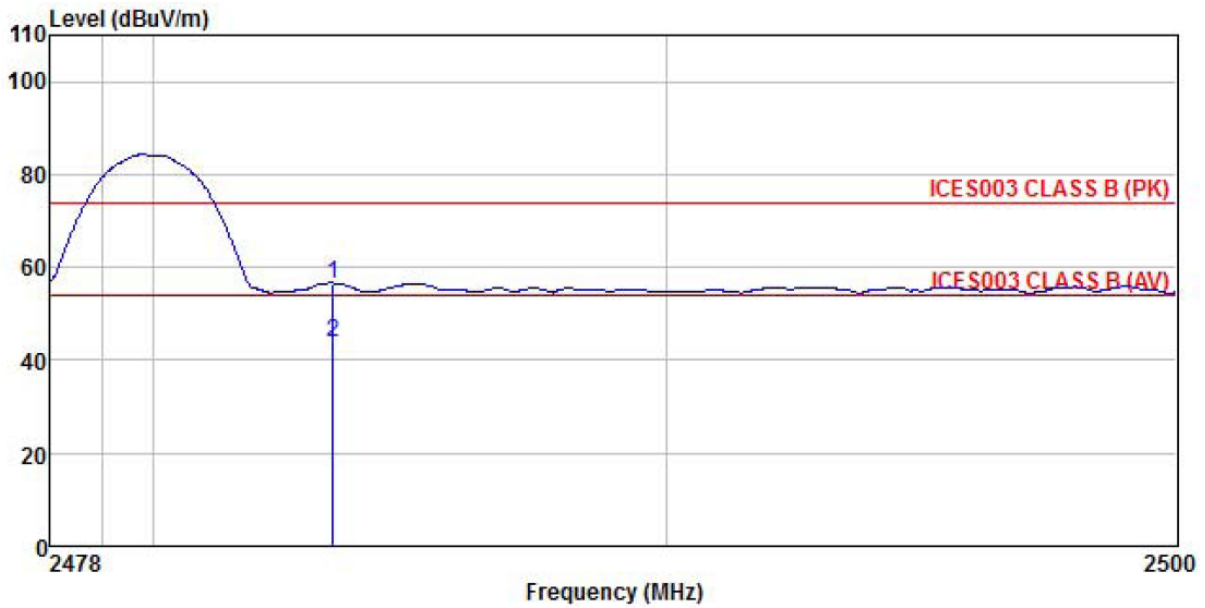

	Freq	Read Level	Antenna Factor	Cable Loss	Preamp Factor	Level	Limit	Over	Remark
	MHz	dBuV	dB/m	dB	dB	dBuV/m	dBuV/m	dB	
1	2483.500	24.41	27.35	4.81	0.00	56.57	74.00	-17.43	Peak
2	2483.500	11.72	27.35	4.81	0.00	43.88	54.00	-10.12	Average

Remark:

- Final Level = Receiver Read level + Antenna Factor + Cable Loss – Pre-amplifier Factor.
- The emission levels of other frequencies are lower than the limit 20dB and not show in test report.

8DPSK mode

Product Name:	Komikan	Product Model:	Komikan
Test By:	Mike	Test mode:	3DH1 Tx mode
Test Channel:	Lowest channel	Polarization:	Vertical
Test Voltage:	AC 120/60Hz	Environment:	Temp: 24°C Huni: 57%

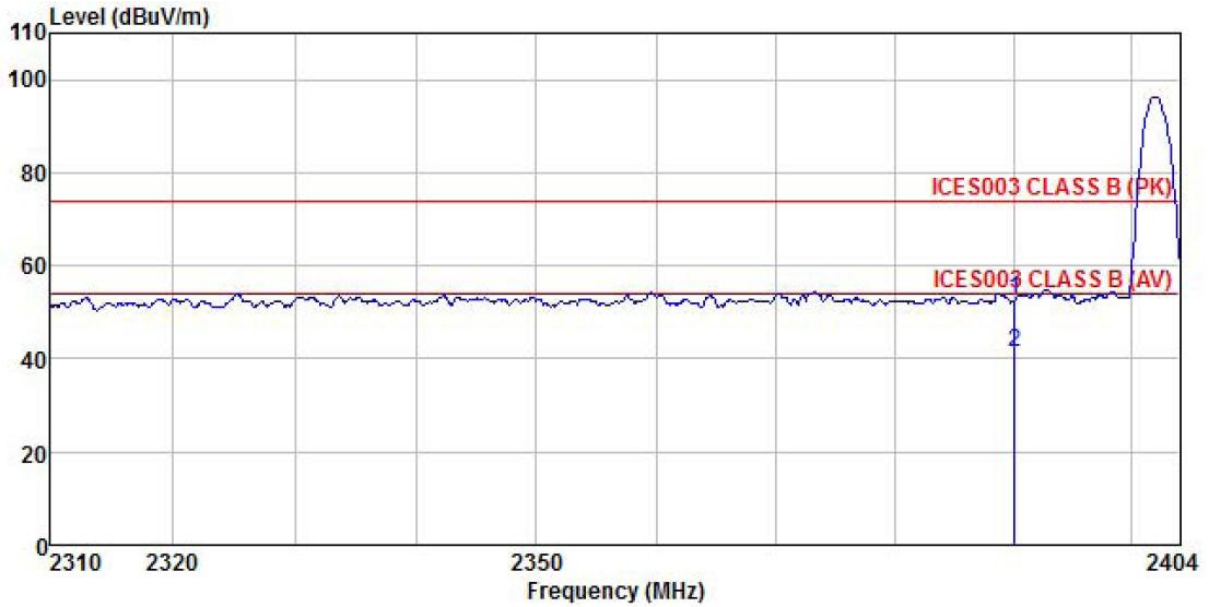

	Freq	Read Level	Antenna Factor	Cable Loss	Preamp Factor	Level	Limit Line	Over Limit	Remark
	MHz	dBuV	dB/m	dB	dB	dBuV/m	dBuV/m	dB	
1	2390.000	21.18	27.07	4.69	0.00	52.94	74.00	-21.06	Peak
2	2390.000	9.71	27.07	4.69	0.00	41.47	54.00	-12.53	Average

Remark:

1. Final Level = Receiver Read level + Antenna Factor + Cable Loss – Pre-amplifier Factor.
2. The emission levels of other frequencies are lower than the limit 20dB and not show in test report.

Product Name:	Komikan	Product Model:	Komikan
Test By:	Mike	Test mode:	3DH1 Tx mode
Test Channel:	Lowest channel	Polarization:	Horizontal
Test Voltage:	AC 120/60Hz	Environment:	Temp: 24°C Humi: 57%

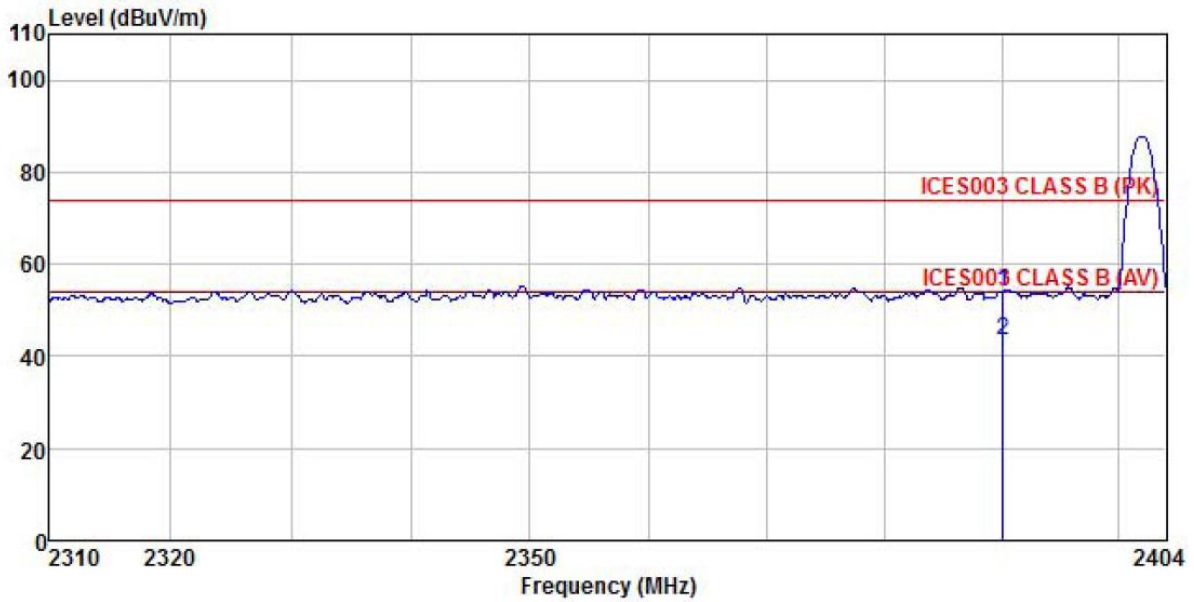

	Freq	Read Level	Antenna Factor	Cable Loss	Preamp Factor	Level	Limit Line	Over Limit	Remark
	MHz	dBuV	dB/m	dB	dB	dBuV/m	dBuV/m	dB	
1	2390.000	22.31	27.08	4.69	0.00	54.08	74.00	-19.92	Peak
2	2390.000	11.81	27.08	4.69	0.00	43.58	54.00	-10.42	Average

Remark:

1. Final Level = Receiver Read level + Antenna Factor + Cable Loss – Pre-amplifier Factor.
2. The emission levels of other frequencies are lower than the limit 20dB and not show in test report.

Product Name:	Komikan	Product Model:	Komikan
Test By:	Mike	Test mode:	3DH1 Tx mode
Test Channel:	Highest channel	Polarization:	Vertical
Test Voltage:	AC 120/60Hz	Environment:	Temp: 24°C Huni: 57%

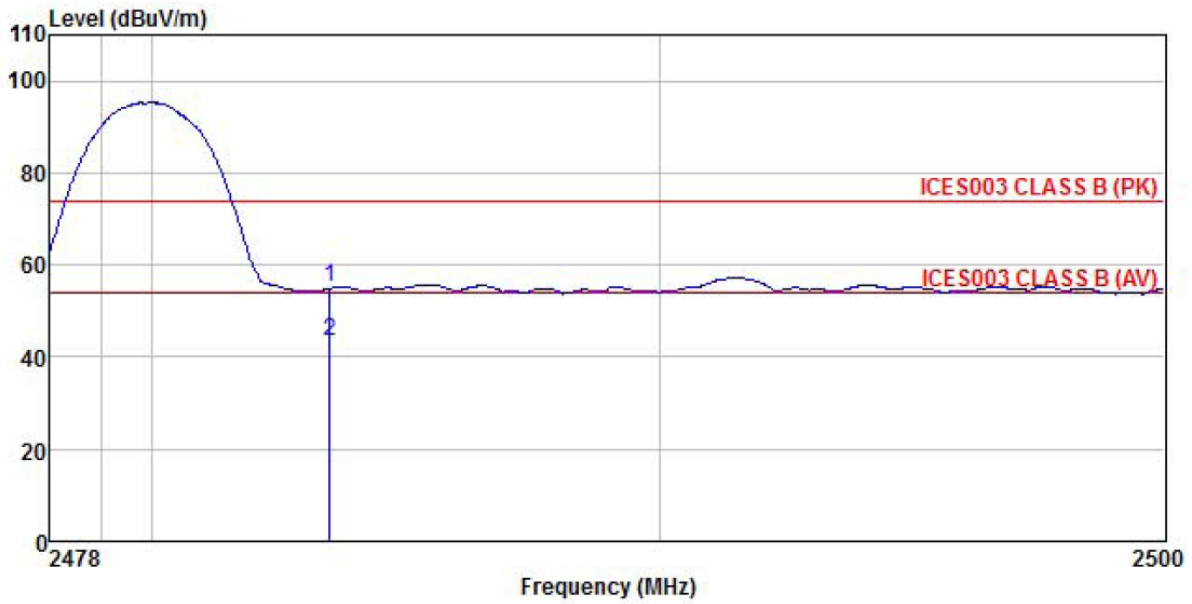

	Read	Antenna	Cable	Preamp	Limit	Over	
Freq	Level	Factor	Loss	Factor	Level	Line	Limit Remark
MHz	dBuV	dB/m	dB	dB	dBuV/m	dBuV/m	dB
1	2483.500	22.88	27.36	4.81	0.00	55.05	74.00 -18.95 Peak
2	2483.500	11.45	27.36	4.81	0.00	43.62	54.00 -10.38 Average

Remark:

1. Final Level = Receiver Read level + Antenna Factor + Cable Loss – Pre-amplifier Factor.
2. The emission levels of other frequencies are lower than the limit 20dB and not show in test report.

Product Name:	Komikan	Product Model:	Komikan
Test By:	Mike	Test mode:	3DH1 Tx mode
Test Channel:	Highest channel	Polarization:	Horizontal
Test Voltage:	AC 120/60Hz	Environment:	Temp: 24°C Huni: 57%

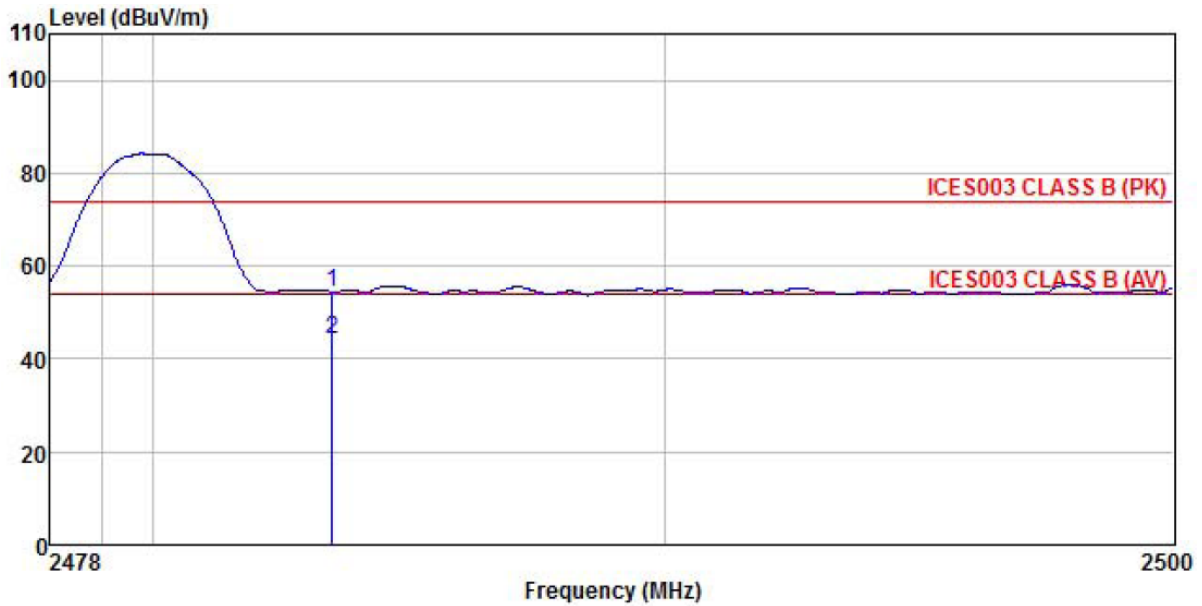

	Read	Antenna	Cable	Preamp	Level	Limit	Over	
Freq	Level	Factor	Loss	Factor	Level	Line	Limit	Remark
MHz	dBuV	dB/m	dB	dB	dBuV/m	dBuV/m	dB	
1	2483.500	22.10	27.35	4.81	0.00	54.26	74.00	-19.74 Peak
2	2483.500	12.06	27.35	4.81	0.00	44.22	54.00	-9.78 Average

Remark:

1. Final Level = Receiver Read level + Antenna Factor + Cable Loss – Preamp Factor.
2. The emission levels of other frequencies are lower than the limit 20dB and not show in test report.

6.9 Spurious Emission

6.9.1 Conducted Emission Method

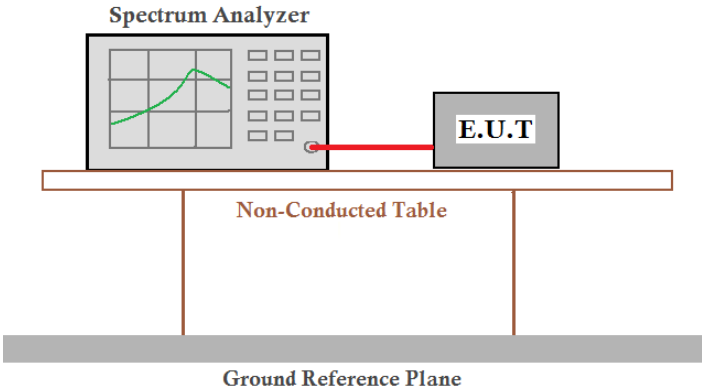
Test Requirement:	RSS-247 Section 5.5
Limit:	In any 100 kHz bandwidth outside the frequency band in which the spread spectrum intentional radiator is operating, the radio frequency power that is produced by the intentional radiator shall be at least 20 dB below that in the 100 kHz bandwidth within the band that contains the highest level of the desired power, based on either an RF conducted or a radiated measurement.
Test setup:	 <p>The diagram illustrates the test setup. A Spectrum Analyzer is connected to an E.U.T (Equipment Under Test) via a red cable. Both the Spectrum Analyzer and the E.U.T are placed on a Non-Conducted Table. The table is supported by a Ground Reference Plane.</p>
Test Instruments:	Refer to section 5.9 for details
Test mode:	Non-hopping mode
Test results:	Pass

Test plot as follows:

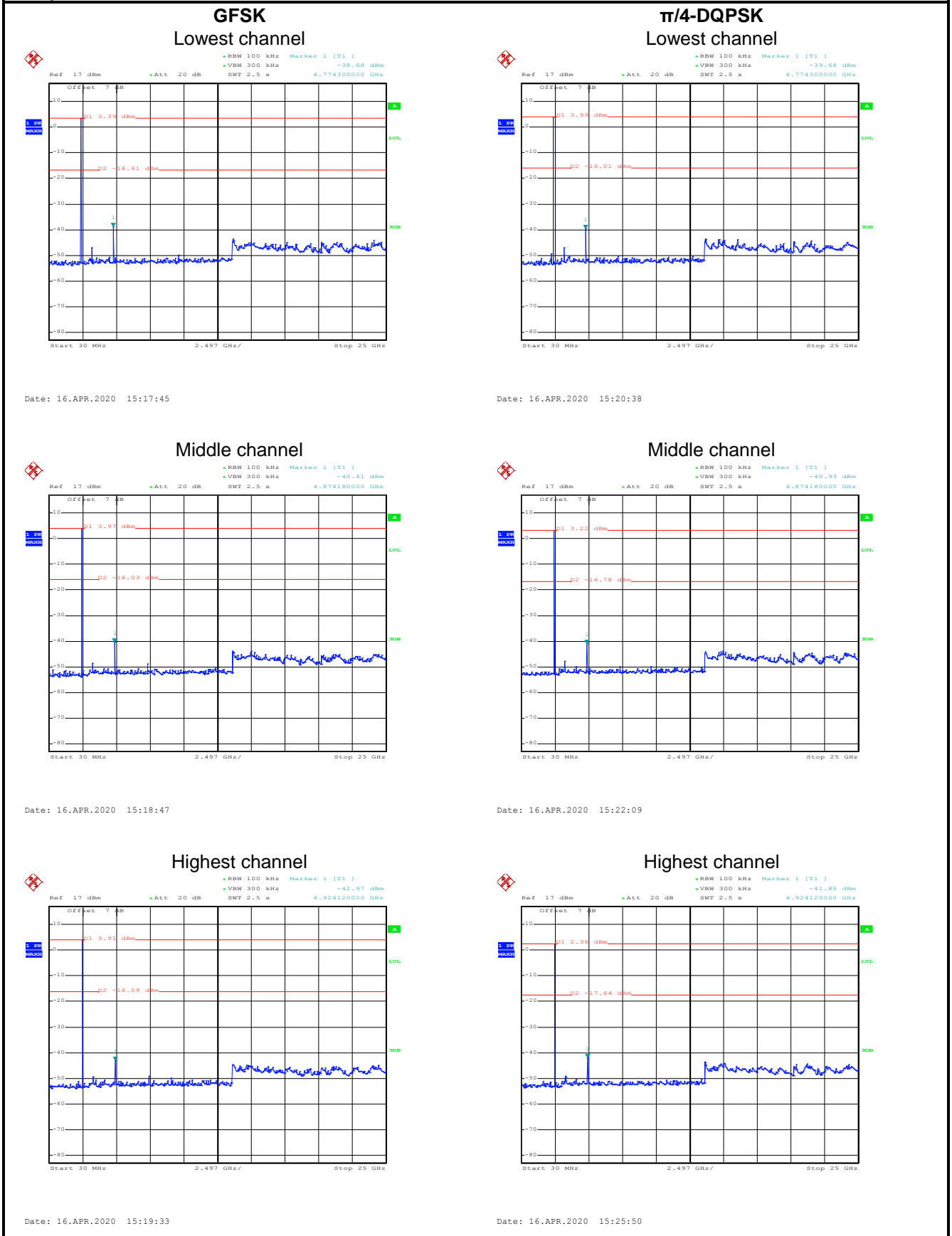

8DPSK

Lowest channel

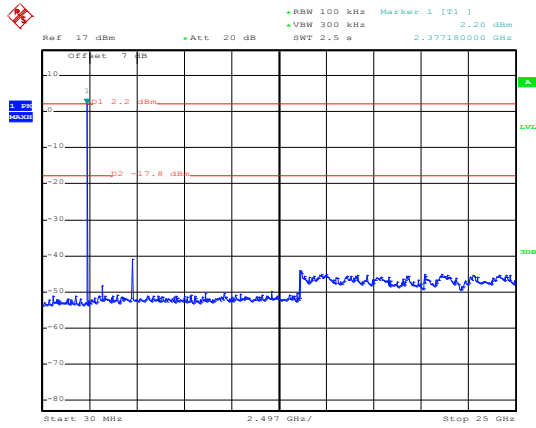

Date: 16.APR.2020 15:26:48

Middle channel

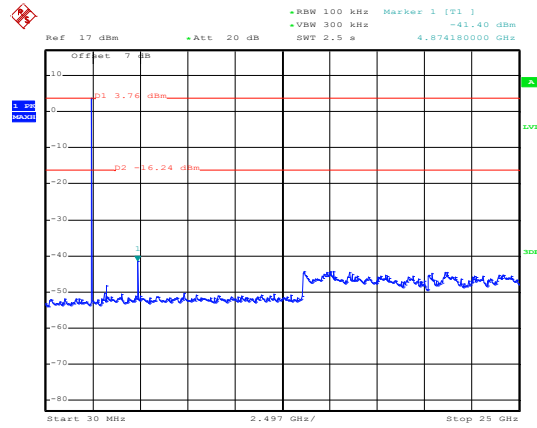

Date: 16.APR.2020 15:27:42

Highest channel

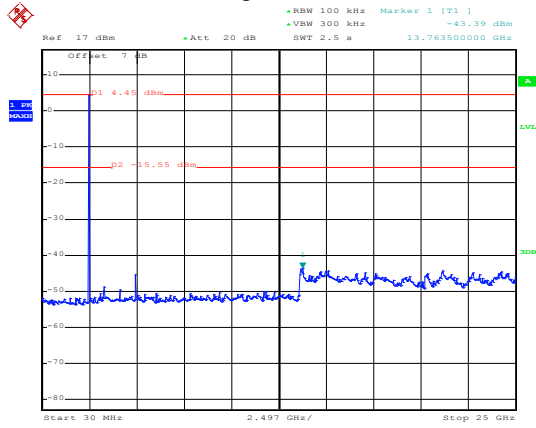

Date: 16.APR.2020 15:28:56

6.9.2 Radiated Emission Method

Test Requirement:	RSS-GEN Section 6.13				
Test Frequency Range:	9 kHz to 25 GHz				
Test Distance:	3m				
Receiver setup:	Frequency	Detector	RBW	VBW	Remark
	30MHz-1GHz	Quasi-peak	120kHz	300kHz	Quasi-peak Value
	Above 1GHz	Peak	1MHz	3MHz	Peak Value
		RMS	1MHz	3MHz	Average Value
Limit:	Frequency	Limit (dBuV/m @3m)		Remark	
	30MHz-88MHz	40.0		Quasi-peak Value	
	88MHz-216MHz	43.5		Quasi-peak Value	
	216MHz-960MHz	46.0		Quasi-peak Value	
	Above 1GHz	54.0		Average Value	
		74.0		Peak Value	
Test setup:	Below 1GHz				
Test setup:	Above 1GHz				
Test Procedure:	<ol style="list-style-type: none"> 1. The EUT was placed on the top of a rotating table 0.8m(below 1GHz) /1.5m(above 1GHz) above the ground at a 3 meter chamber. The table was rotated 360 degrees to determine the position of the highest radiation. 2. The EUT was set 3 meters away from the interference-receiving antenna, which was mounted on the top of a variable-height antenna 				

	<p>tower.</p> <ol style="list-style-type: none"> The antenna height is varied from one meter to four meters above the ground to determine the maximum value of the field strength. Both horizontal and vertical polarizations of the antenna are set to make the measurement. For each suspected emission, the EUT was arranged to its worst case and then the antenna was tuned to heights from 1 meter to 4 meters and the rota table was turned from 0 degrees to 360 degrees to find the maximum reading. The test-receiver system was set to Peak Detect Function and Specified Bandwidth with Maximum Hold Mode. If the emission level of the EUT in peak mode was 10dB lower than the limit specified, then testing could be stopped and the peak values of the EUT would be reported. Otherwise the emissions that did not have 10dB margin would be re-tested one by one using peak, quasi-peak or average method as specified and then reported in a data sheet.
Test Instruments:	Refer to section 5.9 for details
Test mode:	Non-hopping mode
Test results:	Pass
Remark:	<ol style="list-style-type: none"> Pre-scan all kind of the place mode (X-axis, Y-axis, Z-axis), and found the Y-axis is the worst case. 9 kHz to 30 MHz is noise floor, so only shows the data of above 30MHz in this report.

Measurement Data (worst case):

Below 1GHz:

Product Name:	Komikan	Product Model:	Komikan
Test By:	Mike	Test mode:	BT Tx mode
Test Frequency:	30 MHz ~ 1 GHz	Polarization:	Vertical
Test Voltage:	AC 120/60Hz	Environment:	Temp: 24°C Humi: 57%

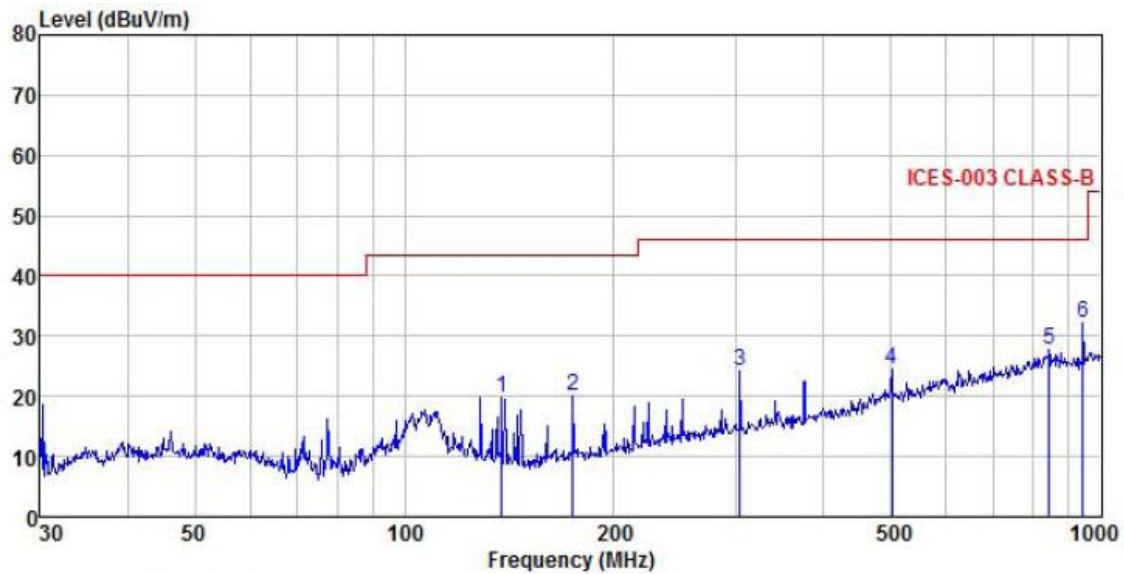

	Freq	ReadAntenna	Cable	Aux	Preamp	Level	Limit	Over	Remark
	MHz	Level	Factor	Loss	Factor	Factor	Line	Limit	
		dBuV	dB/m	dB	dB	dB	dBuV/m	dBuV/m	dB
1	137.903	37.17	9.65	2.37	0.00	29.28	19.91	43.50	-23.59 QP
2	174.424	36.65	9.79	2.69	0.00	29.02	20.11	43.50	-23.39 QP
3	303.544	36.16	13.68	2.95	0.00	28.46	24.33	46.00	-21.67 QP
4	501.179	31.57	18.20	3.63	0.00	28.96	24.44	46.00	-21.56 QP
5	842.130	29.06	22.44	4.22	0.00	28.03	27.69	46.00	-18.31 QP
6	942.131	33.04	22.67	4.13	0.00	27.75	32.09	46.00	-13.91 QP

Remark:

1. Final Level = Receiver Read level + Antenna Factor + Cable Loss – Preamplifier Factor.
2. The emission levels of other frequencies are lower than the limit 20dB and not show in test report.

Product Name:	Komikan	Product Model:	Komikan
Test By:	Mike	Test mode:	BT Tx mode
Test Frequency:	30 MHz ~ 1 GHz	Polarization:	Horizontal
Test Voltage:	AC 120/60Hz	Environment:	Temp: 24°C Huni: 57%

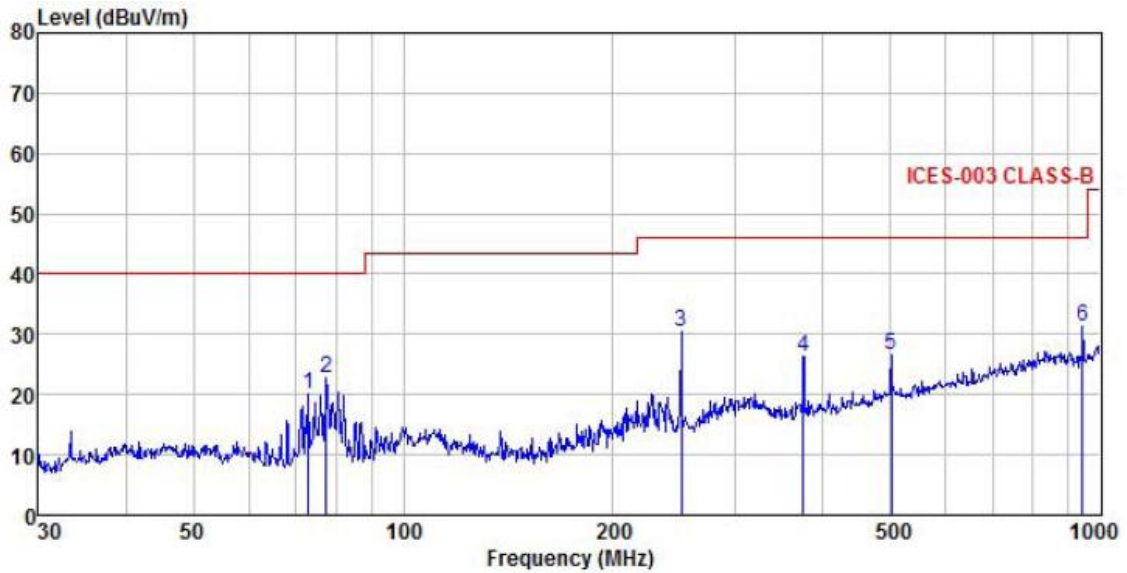

	ReadAntenna	Cable	Aux	Preamp	Level	Limit	Over	Remark
Freq	Level	Loss	Factor	Factor	Level	Line	Limit	
MHz	dBuV	dB/m	dB	dB	dB	dBuV/m	dBuV/m	dB
1	73.103	39.98	8.06	1.59	0.00	29.69	19.94	40.00 -20.06 QP
2	77.593	42.97	7.70	1.64	0.00	29.66	22.65	40.00 -17.35 QP
3	250.301	43.36	12.70	2.81	0.00	28.54	30.33	46.00 -15.67 QP
4	374.623	36.91	14.95	3.09	0.00	28.67	26.28	46.00 -19.72 QP
5	501.179	33.60	18.20	3.63	0.00	28.96	26.47	46.00 -19.53 QP
6	942.131	32.10	22.67	4.13	0.00	27.75	31.15	46.00 -14.85 QP

Remark:

1. Final Level = Receiver Read level + Antenna Factor + Cable Loss – Pre-amplifier Factor.
2. The emission levels of other frequencies are lower than the limit 20dB and not show in test report.

Ceramic Antenna:

Above 1GHz:

Test channel: Lowest channel									
Detector: Peak Value									
Frequency (MHz)	Read Level (dBuV)	Antenna Factor (dB/m)	Cable Loss (dB)	Aux Factor (dB)	Preamp Factor (dB)	Level (dBuV/m)	Limit Line (dBuV/m)	Over Limit (dB)	Polarization
4804.00	50.27	31.02	6.80	2.44	41.81	46.28	74.00	-27.72	Vertical
4804.00	48.67	31.02	6.80	2.44	41.81	44.68	74.00	-29.32	Horizontal
Detector: Average Value									
Frequency (MHz)	Read Level (dBuV)	Antenna Factor (dB/m)	Cable Loss (dB)	Aux Factor (dB)	Preamp Factor (dB)	Level (dBuV/m)	Limit Line (dBuV/m)	Over Limit (dB)	Polarization
4804.00	41.89	31.02	6.80	2.44	41.81	37.90	54.00	-16.10	Vertical
4804.00	39.68	31.02	6.80	2.44	41.81	35.69	54.00	-18.31	Horizontal
Test channel: Middle channel									
Detector: Peak Value									
Frequency (MHz)	Read Level (dBuV)	Antenna Factor (dB/m)	Cable Loss (dB)	Aux Factor (dB)	Preamp Factor (dB)	Level (dBuV/m)	Limit Line (dBuV/m)	Over Limit (dB)	Polarization
4882.00	50.33	31.17	6.86	2.47	41.84	46.52	74.00	-27.48	Vertical
4882.00	48.71	31.17	6.86	2.47	41.84	44.90	74.00	-29.10	Horizontal
Detector: Average Value									
Frequency (MHz)	Read Level (dBuV)	Antenna Factor (dB/m)	Cable Loss (dB)	Aux Factor (dB)	Preamp Factor (dB)	Level (dBuV/m)	Limit Line (dBuV/m)	Over Limit (dB)	Polarization
4882.00	42.37	31.17	6.86	2.47	41.84	38.56	54.00	-15.44	Vertical
4882.00	39.64	31.17	6.86	2.47	41.84	35.83	54.00	-18.17	Horizontal
Test channel: Highest channel									
Detector: Peak Value									
Frequency (MHz)	Read Level (dBuV)	Antenna Factor (dB/m)	Cable Loss (dB)	Aux Factor (dB)	Preamp Factor (dB)	Level (dBuV/m)	Limit Line (dBuV/m)	Over Limit (dB)	Polarization
4960.00	50.49	31.32	6.91	2.49	41.87	46.85	74.00	-27.15	Vertical
4960.00	48.51	31.32	6.91	2.49	41.87	44.87	74.00	-29.13	Horizontal
Detector: Average Value									
Frequency (MHz)	Read Level (dBuV)	Antenna Factor (dB/m)	Cable Loss (dB)	Aux Factor (dB)	Preamp Factor (dB)	Level (dBuV/m)	Limit Line (dBuV/m)	Over Limit (dB)	Polarization
4960.00	42.14	31.32	6.91	2.49	41.87	38.50	54.00	-15.50	Vertical
4960.00	39.63	31.32	6.91	2.49	41.87	35.99	54.00	-18.01	Horizontal
Remark: 1. Final Level = Receiver Read level + Antenna Factor + Cable Loss + Aux Factor – Pre-amplifier Factor. 2. The emission levels of other frequencies are lower than the limit 20dB and not show in test report.									

Flex Antenna:

Above 1GHz:

Test channel: Lowest channel									
Detector: Peak Value									
Frequency (MHz)	Read Level (dBuV)	Antenna Factor (dB/m)	Cable Loss (dB)	Aux Factor (dB)	Preamp Factor (dB)	Level (dBuV/m)	Limit Line (dBuV/m)	Over Limit (dB)	Polarization
4804.00	48.96	31.02	6.80	2.44	41.81	44.97	74.00	-29.03	Vertical
4804.00	50.37	31.02	6.80	2.44	41.81	46.38	74.00	-27.62	Horizontal
Detector: Average Value									
Frequency (MHz)	Read Level (dBuV)	Antenna Factor (dB/m)	Cable Loss (dB)	Aux Factor (dB)	Preamp Factor (dB)	Level (dBuV/m)	Limit Line (dBuV/m)	Over Limit (dB)	Polarization
4804.00	39.06	31.02	6.80	2.44	41.81	35.07	54.00	-18.93	Vertical
4804.00	41.58	31.02	6.80	2.44	41.81	37.59	54.00	-16.41	Horizontal
Test channel: Middle channel									
Detector: Peak Value									
Frequency (MHz)	Read Level (dBuV)	Antenna Factor (dB/m)	Cable Loss (dB)	Aux Factor (dB)	Preamp Factor (dB)	Level (dBuV/m)	Limit Line (dBuV/m)	Over Limit (dB)	Polarization
4882.00	49.44	31.17	6.86	2.47	41.84	45.63	74.00	-28.37	Vertical
4882.00	50.85	31.17	6.86	2.47	41.84	47.04	74.00	-26.96	Horizontal
Detector: Average Value									
Frequency (MHz)	Read Level (dBuV)	Antenna Factor (dB/m)	Cable Loss (dB)	Aux Factor (dB)	Preamp Factor (dB)	Level (dBuV/m)	Limit Line (dBuV/m)	Over Limit (dB)	Polarization
4882.00	38.97	31.17	6.86	2.47	41.84	35.16	54.00	-18.84	Vertical
4882.00	41.96	31.17	6.86	2.47	41.84	38.15	54.00	-15.85	Horizontal
Test channel: Highest channel									
Detector: Peak Value									
Frequency (MHz)	Read Level (dBuV)	Antenna Factor (dB/m)	Cable Loss (dB)	Aux Factor (dB)	Preamp Factor (dB)	Level (dBuV/m)	Limit Line (dBuV/m)	Over Limit (dB)	Polarization
4960.00	49.42	31.32	6.91	2.49	41.87	45.78	74.00	-28.22	Vertical
4960.00	50.73	31.32	6.91	2.49	41.87	47.09	74.00	-26.91	Horizontal
Detector: Average Value									
Frequency (MHz)	Read Level (dBuV)	Antenna Factor (dB/m)	Cable Loss (dB)	Aux Factor (dB)	Preamp Factor (dB)	Level (dBuV/m)	Limit Line (dBuV/m)	Over Limit (dB)	Polarization
4960.00	39.02	31.32	6.91	2.49	41.87	35.38	54.00	-18.62	Vertical
4960.00	42.03	31.32	6.91	2.49	41.87	38.39	54.00	-15.61	Horizontal
Remark:									
1. Final Level = Receiver Read level + Antenna Factor + Cable Loss + Aux Factor – Preamplifier Factor.									
2. The emission levels of other frequencies are lower than the limit 20dB and not show in test report.									

Whip Antenna:

Above 1GHz:

Test channel: Lowest channel									
Detector: Peak Value									
Frequency (MHz)	Read Level (dBuV)	Antenna Factor (dB/m)	Cable Loss (dB)	Aux Factor (dB)	Preamp Factor (dB)	Level (dBuV/m)	Limit Line (dBuV/m)	Over Limit (dB)	Polarization
4804.00	55.83	31.02	6.80	2.44	41.81	51.84	74.00	-22.16	Vertical
4804.00	55.88	31.02	6.80	2.44	41.81	51.89	74.00	-22.11	Horizontal
Detector: Average Value									
Frequency (MHz)	Read Level (dBuV)	Antenna Factor (dB/m)	Cable Loss (dB)	Aux Factor (dB)	Preamp Factor (dB)	Level (dBuV/m)	Limit Line (dBuV/m)	Over Limit (dB)	Polarization
4804.00	49.14	31.02	6.80	2.44	41.81	45.15	54.00	-8.85	Vertical
4804.00	49.37	31.02	6.80	2.44	41.81	45.38	54.00	-8.62	Horizontal
Test channel: Middle channel									
Detector: Peak Value									
Frequency (MHz)	Read Level (dBuV)	Antenna Factor (dB/m)	Cable Loss (dB)	Aux Factor (dB)	Preamp Factor (dB)	Level (dBuV/m)	Limit Line (dBuV/m)	Over Limit (dB)	Polarization
4882.00	55.53	31.17	6.86	2.47	41.84	51.72	74.00	-22.28	Vertical
4882.00	55.88	31.17	6.86	2.47	41.84	52.07	74.00	-21.93	Horizontal
Detector: Average Value									
Frequency (MHz)	Read Level (dBuV)	Antenna Factor (dB/m)	Cable Loss (dB)	Aux Factor (dB)	Preamp Factor (dB)	Level (dBuV/m)	Limit Line (dBuV/m)	Over Limit (dB)	Polarization
4882.00	48.82	31.17	6.86	2.47	41.84	45.01	54.00	-8.99	Vertical
4882.00	48.99	31.17	6.86	2.47	41.84	45.18	54.00	-8.82	Horizontal
Test channel: Highest channel									
Detector: Peak Value									
Frequency (MHz)	Read Level (dBuV)	Antenna Factor (dB/m)	Cable Loss (dB)	Aux Factor (dB)	Preamp Factor (dB)	Level (dBuV/m)	Limit Line (dBuV/m)	Over Limit (dB)	Polarization
4960.00	55.85	31.32	6.91	2.49	41.87	52.21	74.00	-21.79	Vertical
4960.00	55.56	31.32	6.91	2.49	41.87	51.92	74.00	-22.08	Horizontal
Detector: Average Value									
Frequency (MHz)	Read Level (dBuV)	Antenna Factor (dB/m)	Cable Loss (dB)	Aux Factor (dB)	Preamp Factor (dB)	Level (dBuV/m)	Limit Line (dBuV/m)	Over Limit (dB)	Polarization
4960.00	48.96	31.32	6.91	2.49	41.87	45.32	54.00	-8.68	Vertical
4960.00	48.88	31.32	6.91	2.49	41.87	45.24	54.00	-8.76	Horizontal
Remark: 1. Final Level = Receiver Read level + Antenna Factor + Cable Loss + Aux Factor – Pre-amplifier Factor. 2. The emission levels of other frequencies are lower than the limit 20dB and not show in test report.									

7 Test Setup Photo

Radiated Spurious Emission (Ceramic Antenna)
Below 1GHz

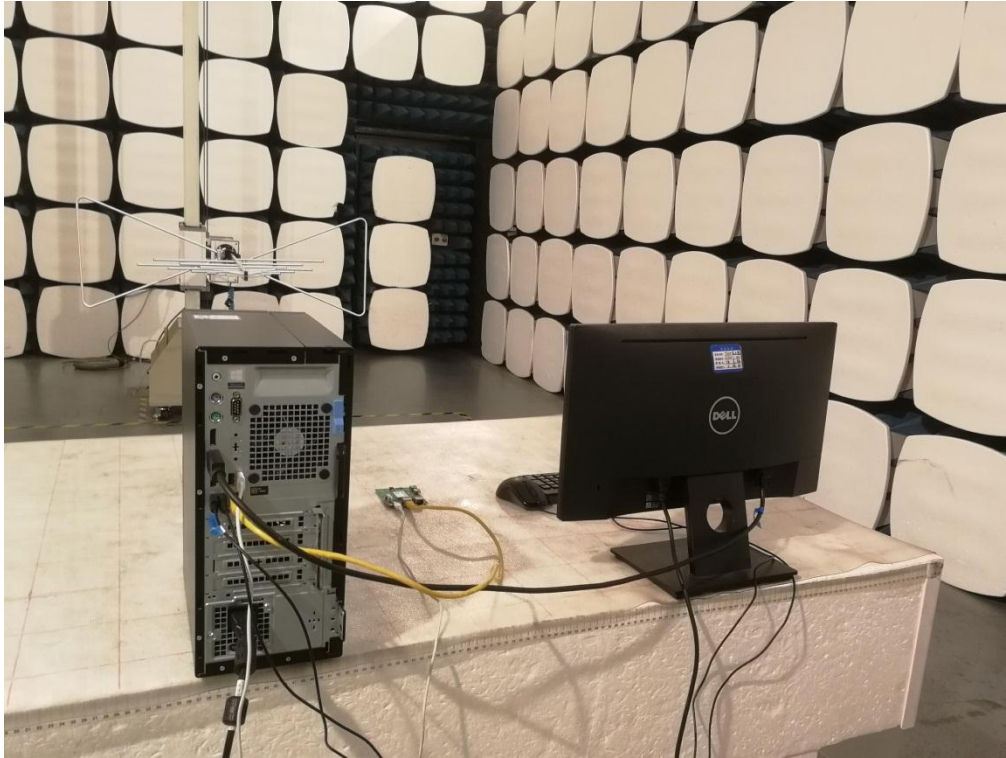

Above 1GHz



Radiated Spurious Emission (Flex Antenna) Below 1GHz

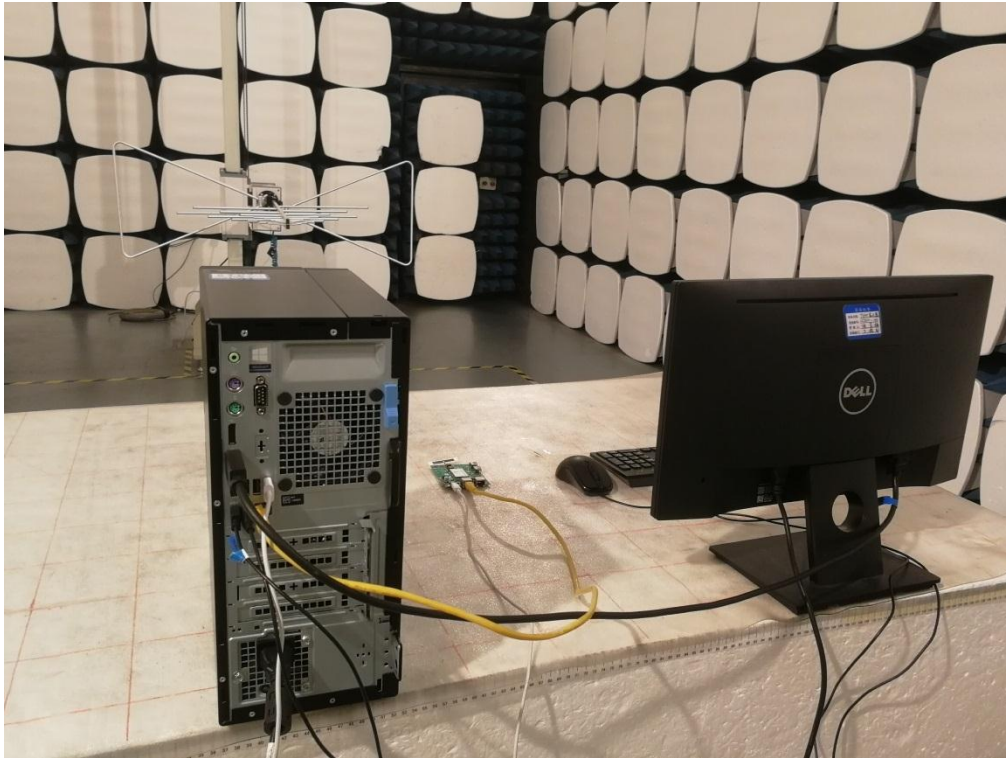

Above 1GHz



Radiated Spurious Emission (Whip Antenna)
Below 1GHz

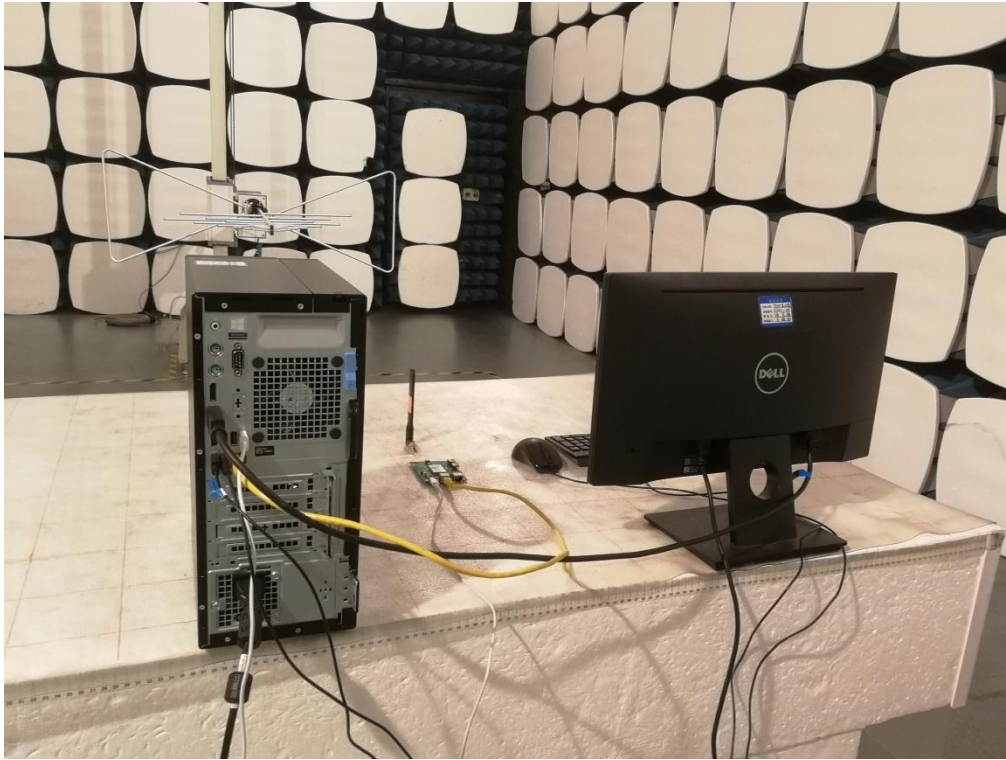

Above 1GHz

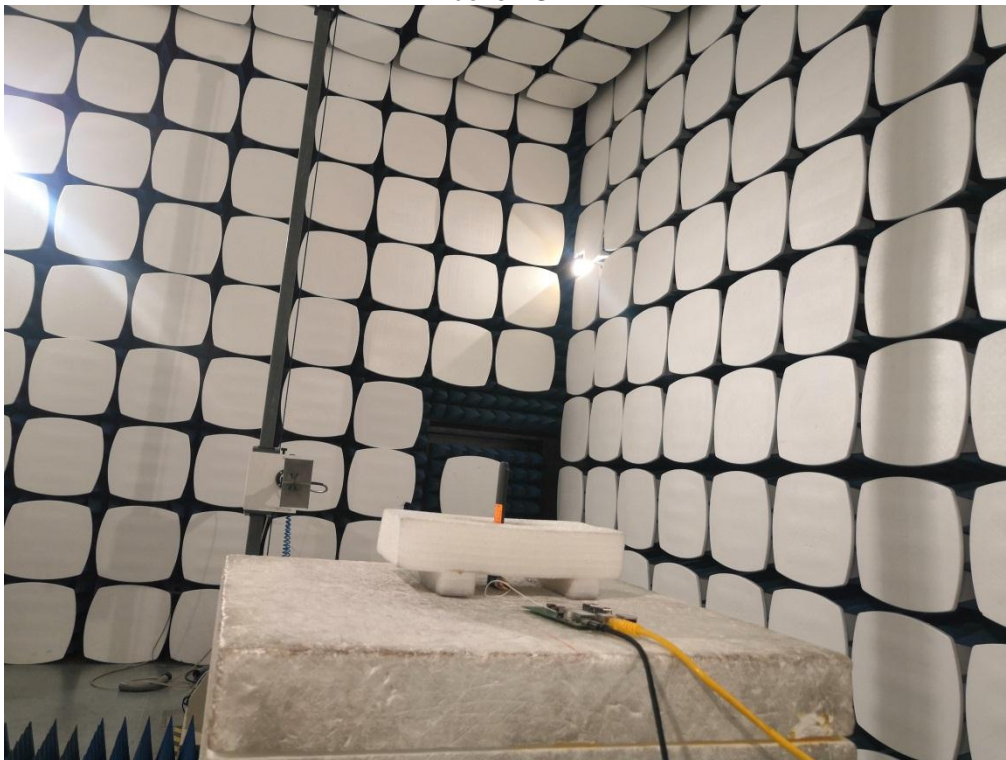

Conducted Emission



8 EUT Constructional Details

Reference to the test report No.: CCISE200308101

-----End of report-----