



**KAS-33100-0004**  
*MUSKIE*

# Knowles SiSonic™ MEMS Microphone Evaluation Kit

## KIT OVERVIEW

- ▶ Simple evaluation of Knowles SiSonic™ MEMS microphones
- ▶ Interfaces to Knowles standard flex circuits and coupons
- ▶ Works with most microphone output formats
- ▶ Wide dynamic range
- ▶ Facilitates measuring microphone current consumption

## KIT Features

- ▶ 2 independent channels of audio supporting multiple MEMS microphone output formats
- ▶ Supports Analog, Differential Analog, Digital PDM, and Digital I2S microphones
- ▶ Selectable Clock Frequencies, Voltages, and Audio gains

KEY PARAMETERS	TARGET SPECIFICATIONS
Input Interfaces	Analog, Differential, PDM, I2S
Output Connectors	XLR, 3.5mm Headset Audio Jack, Micro USB
Dynamic Range	Varies with microphone type and selected audio path
USB Sampling Rate	48kHz
Microphone Supply voltage	Selectable: 1.8V, 2.75V, 3.3V Variable: 1.65V – 3.6V
Digital Microphone Clock Rates	768KHz, 1.024MHz, 1.536MHz, 2.048MHz, 2.4MHz, 2.822MHz, 3.072MHz, 4.095MHz, 4.8MHz
Dimensions	5 x 4 x 1.5 inches

## THE “MUSKIE” EVALUATION PLATFORM



## CONTACT

For inquiries, please contact a Knowles representative or distributor.

## BLOCK DIAGRAM

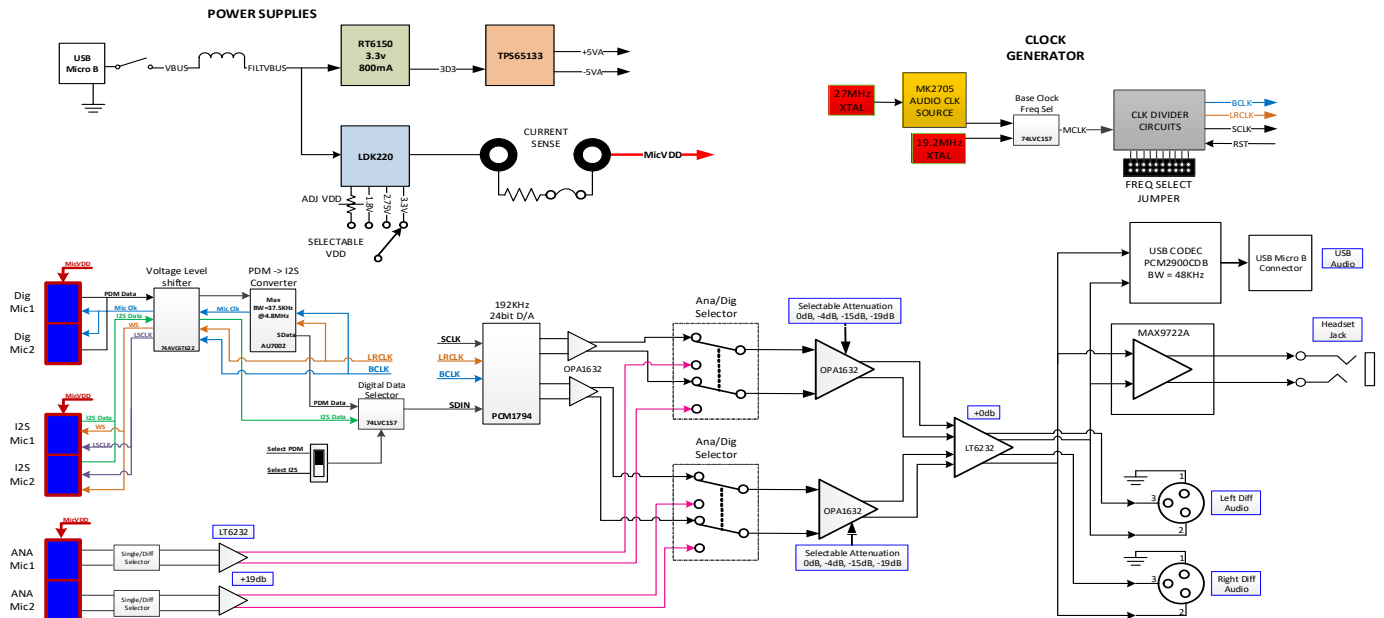

## DISCLAIMER

The information given in this document shall in no event be regarded as a guarantee of conditions or characteristics. With respect to any examples given herein, any typical values stated herein and/or any information regarding the application of the device, Knowles Electronics, LLC hereby disclaims any and all warranties and liabilities of any kind, including without limitation warranties of non-infringement of intellectual property rights of any third party.

## INFORMATION

For further information on technology, delivery terms and conditions and prices, please contact a Knowles representative.

© 2019, Knowles Electronics, LLC, Itasca, IL, USA. All Rights Reserved. Knowles and the logo are trademarks of Knowles Electronics, LLC.

