

PAJ7620U2: Integrated Gesture Recognition Sensor

General Description

The PAC7620 integrates gesture recognition function with general I²C interface into a single chip forming an image analytic sensor system. It can recognize 9 human hand gesticulations such as moving up, down, left, right, forward, backward, circle-clockwise, circle-counter clockwise, and waving. It also offers built-in proximity detection in sensing approaching or departing object from the sensor. The PAC7620 is designed with great flexibility in power-saving mechanism, well suit for low power battery operated HMI devices. The PAJ7620 is packaged into module form in-built with IR LED and optics lens as a complete sensor solution

Key Features

- Gesture/Cursor/Image modes
- Built-in proximity detection
- Gesture speed is 60~600°/s in Normal Mode and 60~1200°/s in Gaming Mode
- Flexible power saving scheme
- Communication interface options
 - I²C (for Gesture/Cursor mode)
 - 4-wire SPI (for Image mode)
- I²C interface up to 400 Kbit/s
- SPI interface range from
 - 22~48 MHz (Frame subtraction mode)
 - 44~48 MHz (Raw data mode)
- Ambient light immunity
- Ambient light noise cancellation

Applications

- PAD Phone
- Tablet Personal Computer
- Automobile Application

Key Parameters

Parameter	Value
Array Size	60x60 pixels
Pixel Size	20x20 μm ²
Max Frame Rate	720 fps @ 240 report rate
Input Clock	22MHz for SPI Image Out 44MHz for SPI raw data mode
Supply Voltage	VDD: 2.8~3.6V VBUS: 1.8~3.3V VLED: 3.0~4.2V
Current Consumption	Operation State: 2.82 mA Standby 1 State: 2.3mA Standby 2 State: 1.5mA
Package Dimensions	5.2x3x1.88 mm ³

Ordering Information

Part Number	Package Type
PAJ7620U2	13-pins LGA Module



Lead (Pb) Free
RoHS 6 fully
compliant



For any additional inquiries, please contact us at
<http://www.pixart.com/contact.asp>.

Table of Contents

PAJ7620U2: Integrated Gesture Recognition Sensor 1

General Description..... 1

Key Features 1

Applications 1

Key Parameters 1

Ordering Information 1

1.0 Sensor Overview 7

1.1 Gesture Mode 7

1.2 Image Mode 7

1.3 Architecture Block Diagram 7

1.4 Signal Description 7

1.5 Pin Configuration..... 8

2.0 Mechanical Specifications..... 9

2.1 Package Dimension 9

2.2 IR Reflow Recommendation 10

2.2.1 Recommended Pb-free Solder Paste 10

2.2.2 IR Reflow Soldering Profile..... 10

2.3 Recommend Mechanical Design 11

2.4 Recommended IR Ink Spectrum 13

3.0 Reference Schematics 14

4.0 Sensor Specifications..... 15

4.1 Absolute Maximum Ratings, $T_A = 27^{\circ}\text{C}$ 15

4.2 Recommended Operating Condition..... 15

4.3 Electrical Specifications, $V_{DD}=2.8\text{V}$, $T_A = 27^{\circ}\text{C}$ 16

4.4 Gesture Functional Specifications 16

4.5 Interface AC Specifications 17

5.0 Serial Interface Communication 18

5.1 I²C Interface..... 18

5.1.1 I²C Protocol 18

5.1.2 I²C Timing Parameter 19

5.2 Four-Wire SPI Interface (For Image Mode Only) 20

5.2.1 SPI Master Protocol..... 20

5.2.2 SPI Timing Parameter 20

6.0 Operation Principles 21

6.1 Gesture mode..... 21

6.1.1 Module Orientation 21

6.1.2 Power-On Sequence 21

6.1.3 Gesture Detection Operating State..... 22

6.2 Image mode..... 25

6.2.1 Output Image Timing 25

6.2.2 Suspend State 25

6.3 Proximity Detection Mode 26

6.3.1 Proximity Detection Operating State 26

7.0 Register Tables..... 28

7.1 Register Bank Select 28

7.2 Image Size Setting 28

7.3 Setting 30x30 Pixels Image Output Mode 28

7.4 AE/AG Controls..... 30

7.5 GPIO Setting 31

7.6 Interrupt Controls..... 32

7.7 Gesture Mode Controls 33

7.8 Cursor Mode Controls 37

7.9 Proximity Mode Controls..... 38

7.10 EFuse Program Controls 39

7.11 Background Controls 40

7.12 Lens Shading Compensation..... 41

7.13 LED Controls 41

7.14 Sleep Mode 42

7.15 Clock Controls..... 44

7.16 Chip/Version ID..... 45

7.17 Suspend/Reset..... 45

7.18 Test Mode 45

7.19 Reserved Registers List 47

8.0 Firmware Guides..... 51

8.1 Initialization of PAJ7620U2..... 51

8.2 Get Gesture Result 52

8.3 Change to PS Mode 52

8.4 Get PS Approach Status 53

8.5 Change to Gesture mode 53

8.6 Enter Suspend mode 54

8.7 Resume to Gesture Mode 54

Document Revision History60

please ask for full datasheet

List of Figures

Figure 1. Architecture Block Diagram 7

Figure 2. PAJ7620U2 Module Pin Configuration (BTM VIEW)..... 8

Figure 3. PAJ7620U2 Package Outline Diagram 9

Figure 4. IR Reflow Profile..... 10

Figure 5. PAJ7620U2 Mechanical Design Guide..... 11

Figure 6. PAJ7620U2 Mechanical Design Guide (IR Ink Suggestion) 12

Figure 7. IR Ink Spectrum..... 13

Figure 8. PAJ7620U2 Application Circuit..... 14

Figure 9. Start and Stop Conditions 18

Figure 10. Valid Data 18

Figure 11. Single Write Protocol 18

Figure 12. Single Read Protocol 18

Figure 13. Burst Read Protocol 18

Figure 14. I²C Wake-up command Protocol 18

Figure 15. I²C Timing Diagram 19

Figure 16. SPI Master Protocol 20

Figure 17. SPI Timing Diagram 20

Figure 18. Module Orientation of PAJ7620U2 (Front View)..... 21

Figure 19. PAJ7620U2 Power-On Timing Diagram 22

Figure 20. Operation State (OP state) Diagram..... 22

Figure 21. Standby 1 State (S1 state) Diagram..... 23

Figure 22. Standby 2 State (S2 state) Diagram..... 23

Figure 23. Suspend State (SUS state) Diagram..... 24

Figure 24. State Machine of Gesture Detection..... 24

Figure 25. Timing of Output Image for 30x30 pixels..... 25

Figure 26. Timing of Output Image for 60x60 pixels..... 25

Figure 27. Suspend State (SUS state) Diagram..... 26

Figure 28. Proximity Sensing Functional Diagram..... 26

Figure 29. Proximity Operation State (PS OP state) Diagram 26

Figure 30. Suspend State (SUS state) Diagram..... 27

Figure 31. State Machine of Proximity Detection 27

Figure 32. 2x Skip Mode 29

Figure 33. 2x2 Average Mode 29

Figure 34. WOI Mode 29

List of Tables

Table 1. Gesture Detecting Range and View Angle 7
Table 2. Signal Description..... 7
Table 3. PAJ7620U2 Pin Definition 8

please ask for full datasheet

1.0 Sensor Overview

1.1 Gesture Mode

For Gesture Mode, there are 9 gestures recognition being embedded in the sensor including move up, move down, move left, move right, move forward, move backward, circle-clockwise, circle-counter clockwise, and wave. These gestures information can be simply accessed by register reading via I²C bus. The normal gesture detecting range from 5 to 15 cm from where PAC7620 is located through the operating view angle of diagonally 60° respectively. Additionally, The PAC7620 can be configured as Normal Mode (Gesture speed is 60°/s - 600°/s) or Gaming Mode (Gesture speed is 60°/s - 1200°/s) for different applications. The PAC7620 also offer built-in proximity detection for the purpose of sensing object approaching or departing.

Table 1. Gesture Detecting Range and View Angle

Part Number	Detecting Range	View Angle (Diagonal)
PAJ7620U2	5 to 15 cm	60°

1.2 Image Mode

For image mode, the typical report rate is 120Hz with image size equals 30x30 (Frame subtraction mode, WOI) or 30x30 (Raw data mode, WOI). The depth of pixel data depth is 9 bit and output through the SPI bus. The SCK rate of SPI bus equals to the external SPI clock input ranging from 22 to 48 MHz (Frame subtraction mode) or 44 to 48 MHz (Raw data mode). By programming the internal register set via I²C serial control bus, it performs on-chip report rate, exposure time, gain adjustment, array skip mode, and array average mode.

1.3 Architecture Block Diagram

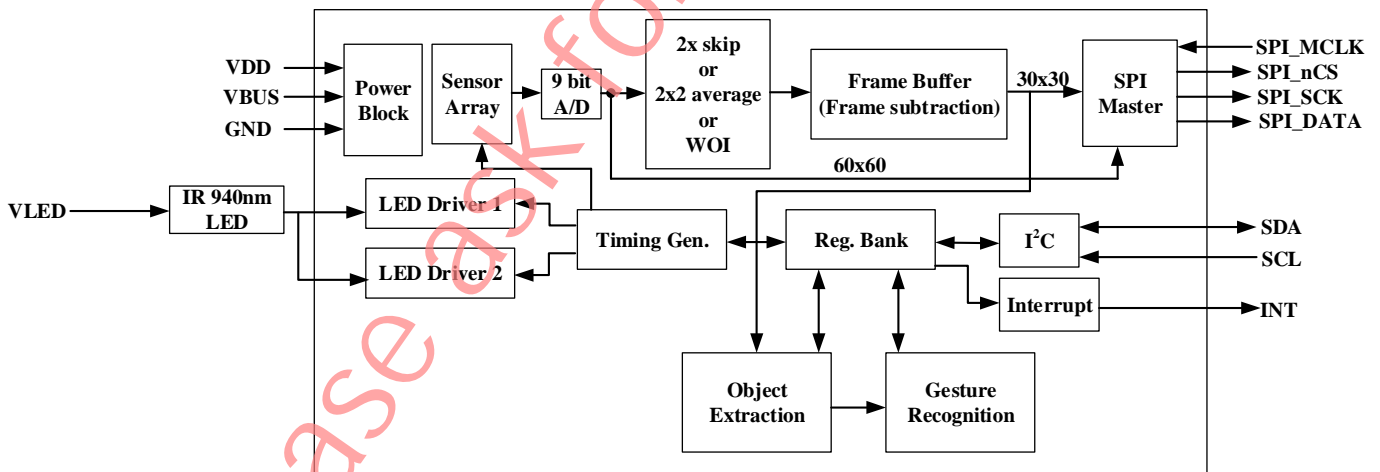

Figure 1. Architecture Block Diagram

1.4 Signal Description

Table 2. Signal Description

Signal Name	Description
SDA	I ² C data pin

SCL	I ² C clk pin
INT_N	Interrupt pin (Active low) for Gesture Mode.
GPIO3(SPI_DATA)	Data out of SPI master for image mode
GPIO2(SPI_SCK)	SCK signal of SPI master for image mode
GPIO1(SPI_nCS)	nCS signal of SPI master for image mode
GPIO0(SPI_MCLK)	External clock input of SPI master for image mode

1.5 Pin Configuration

Table 3. PAJ7620U2 Pin Definition

Pin No.	Symbol	Type	Function
1	V _{BUS}	POWER	BUS power supply
2	SDA	IN/OUT	I ² C data pin (Open Drain)
3	INT_N	OUT	Interrupt pin (Active low) (Open Drain)
4	TESTMD	IN	For Module Test Only
5	SCL	IN	I ² C clock pin (Open Drain)
6, 10	GND	GND	Ground
7	GPIO3 (SPI_DATA)	SPI Mode : OUT GPIO Mode : IN/OUT	SPI Mode : Data out of SPI master GPIO Mode : GPIO
8	GPIO2 (SPI_SCK)	SPI Mode : OUT GPIO Mode : IN/OUT	SPI Mode : SCK signal of SPI master GPIO Mode : GPIO
9	GPIO1 (SPI_nCS)	SPI Mode : OUT GPIO Mode : IN/OUT	SPI Mode : Chip select signal of SPI master (Active Low) GPIO Mode : GPIO
11	V _{LED}	POWER	LED power input
12	V _{DD}	POWER	Main power supply
13	GPIO0 (SPI_MCLK)	SPI Mode : IN GPIO Mode : IN/OUT	SPI Mode : External clock input for SPI GPIO Mode : GPIO

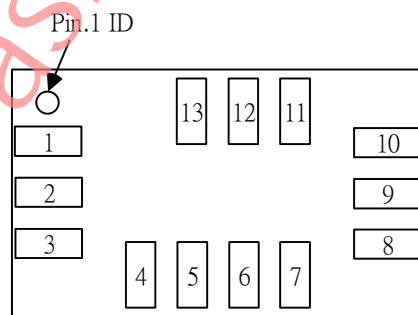

Figure 2. PAJ7620U2 Module Pin Configuration (BTM VIEW)

2.0 Mechanical Specifications

2.1 Package Dimension

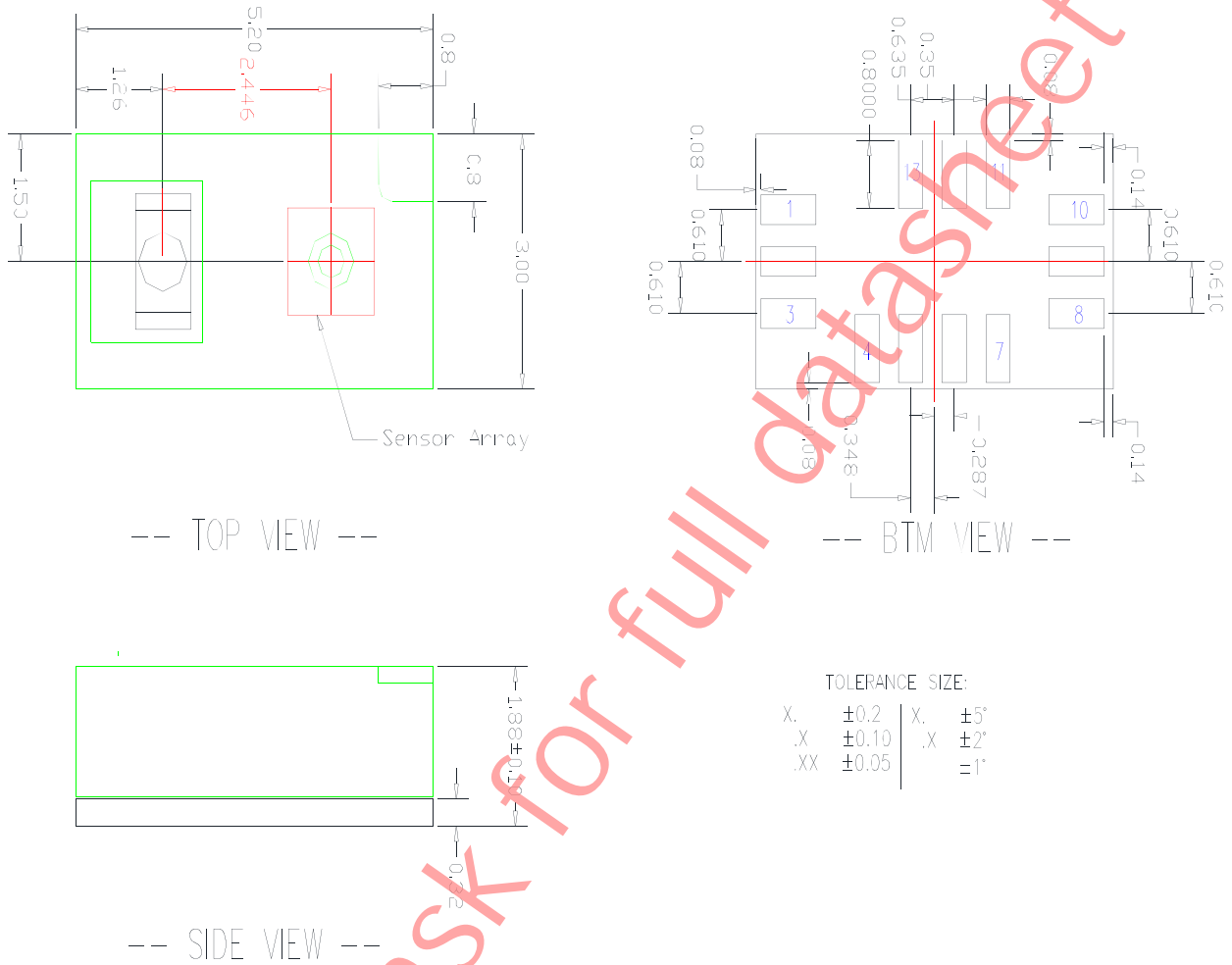

Figure 3. PAJ7620U2 Package Outline Diagram

2.2 IR Reflow Recommendation

2.2.1 Recommended Pb-free Solder Paste

- Almit LFM-48W TM-HP
- Senju M705-GRN360-K

2.2.2 IR Reflow Soldering Profile

Temperature profile is the most important control in reflow soldering. It must be fine-tuned to establish a robust process. The typical recommended IR reflow profile is shown in Figure 4 below.

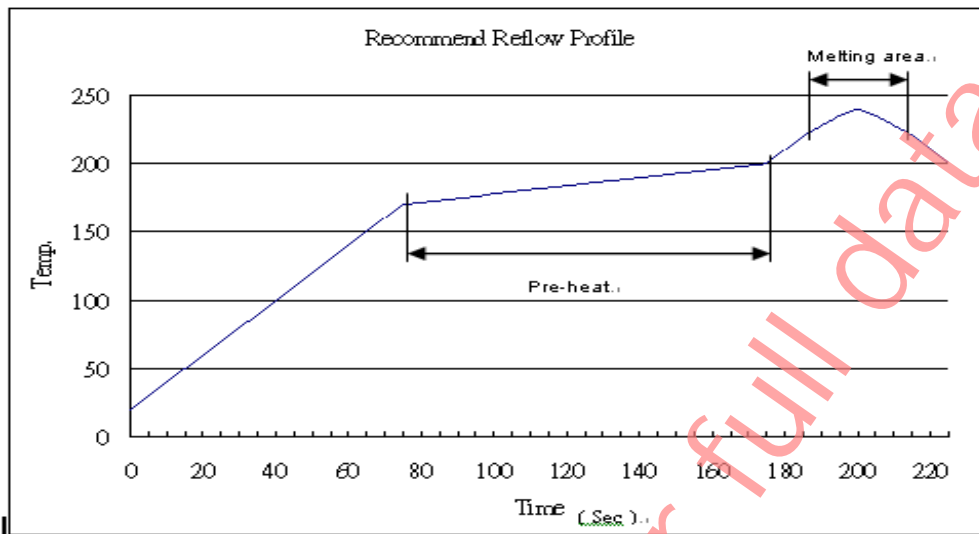

Figure 4. IR Reflow Profile

Reflow Profile:

- I. Average Ramp-up Rate (30°C to preheat zone): 1.5~ 2.5 Degree C/ Sec
- II. Preheat zone:
 - Temp ramp from 170~ 200 degree C
 - Exposure time: 90 +/- 30 sec
- III. Melting zone:
 - Melting area temp > 220 degree C for at least 30 ~ 50 sec
 - Peak temperature : 245 degree C

2.3 Recommend Mechanical Design

PXI suggest mechanical design as below to optimize the performance.

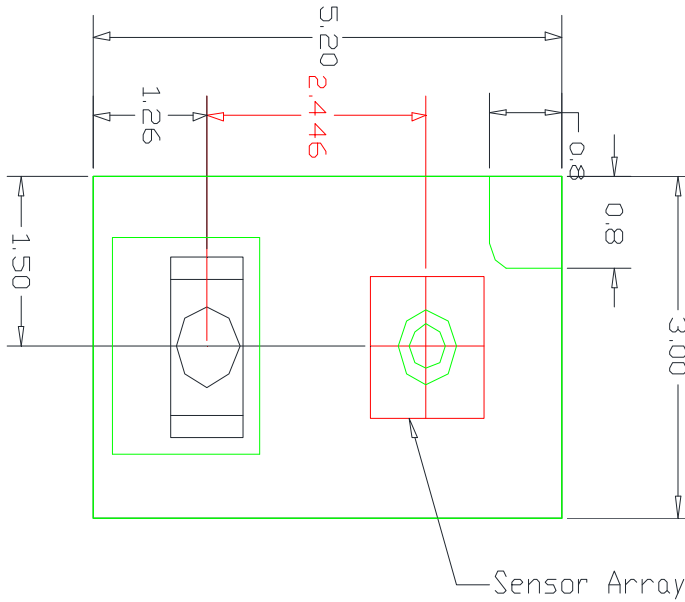

Note:

1. Recommended Cover Glass Material: Glass or PC
2. Clear Glass Part Transparency: > 90%
3. Cover Glass Thickness $\leq 0.7\text{mm}$
4. Cover Glass and PAJ7620U2 are close as much as possible. Air Gap $\leq 0.2\text{mm}$

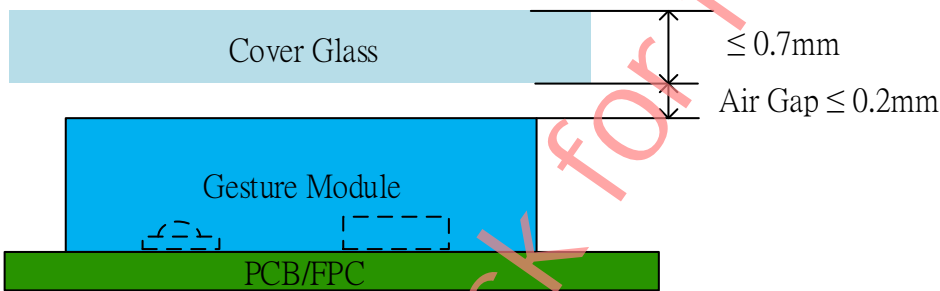
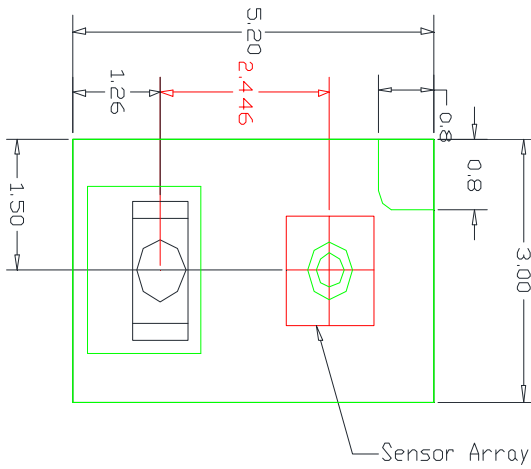

Figure 5. PAJ7620U2 Mechanical Design Guide



Note:

1. If thickness of cover glass $\leq 0.7\text{mm}$, and Air Gap $\leq 0.2\text{mm}$, the black Ink region is not necessary.
2. For appearance reason, Ink on cover may be necessary. Please follow the IR Ink spectrum above

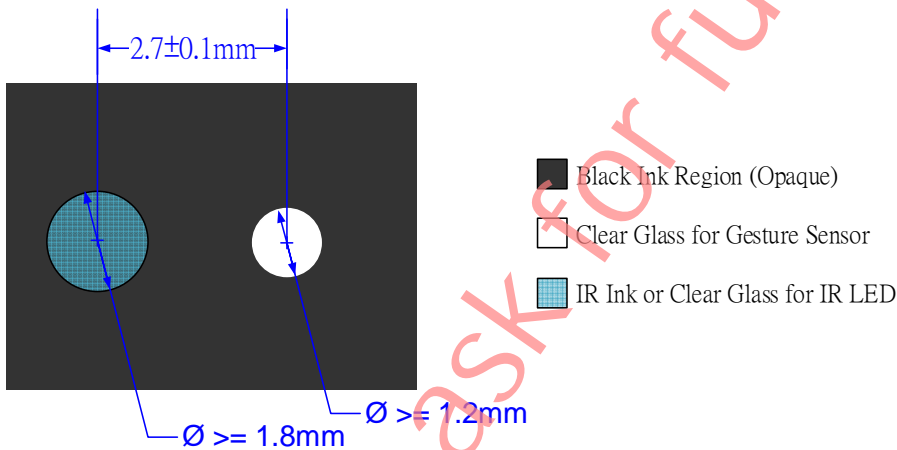
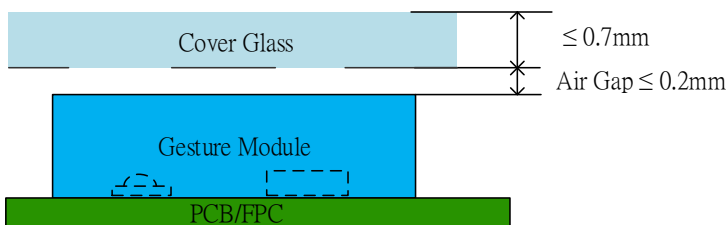

Figure 6. PAJ7620U2 Mechanical Design Guide (IR Ink Suggestion)

2.4 Recommended IR Ink Spectrum

IR Ink Vendor: Teikoku Ink

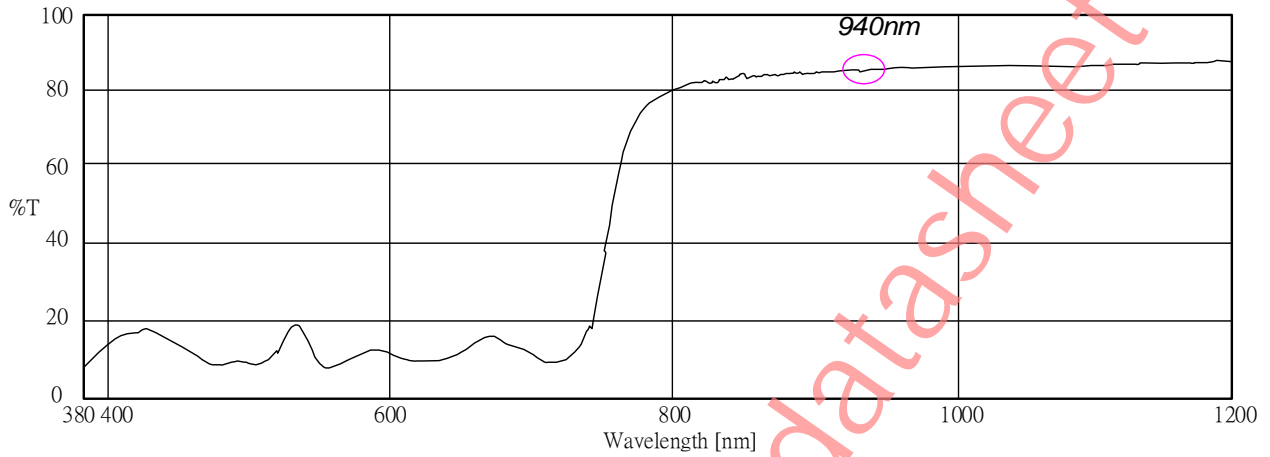

Figure 7. IR Ink Spectrum

please ask for full datasheet

3.0 Reference Schematics

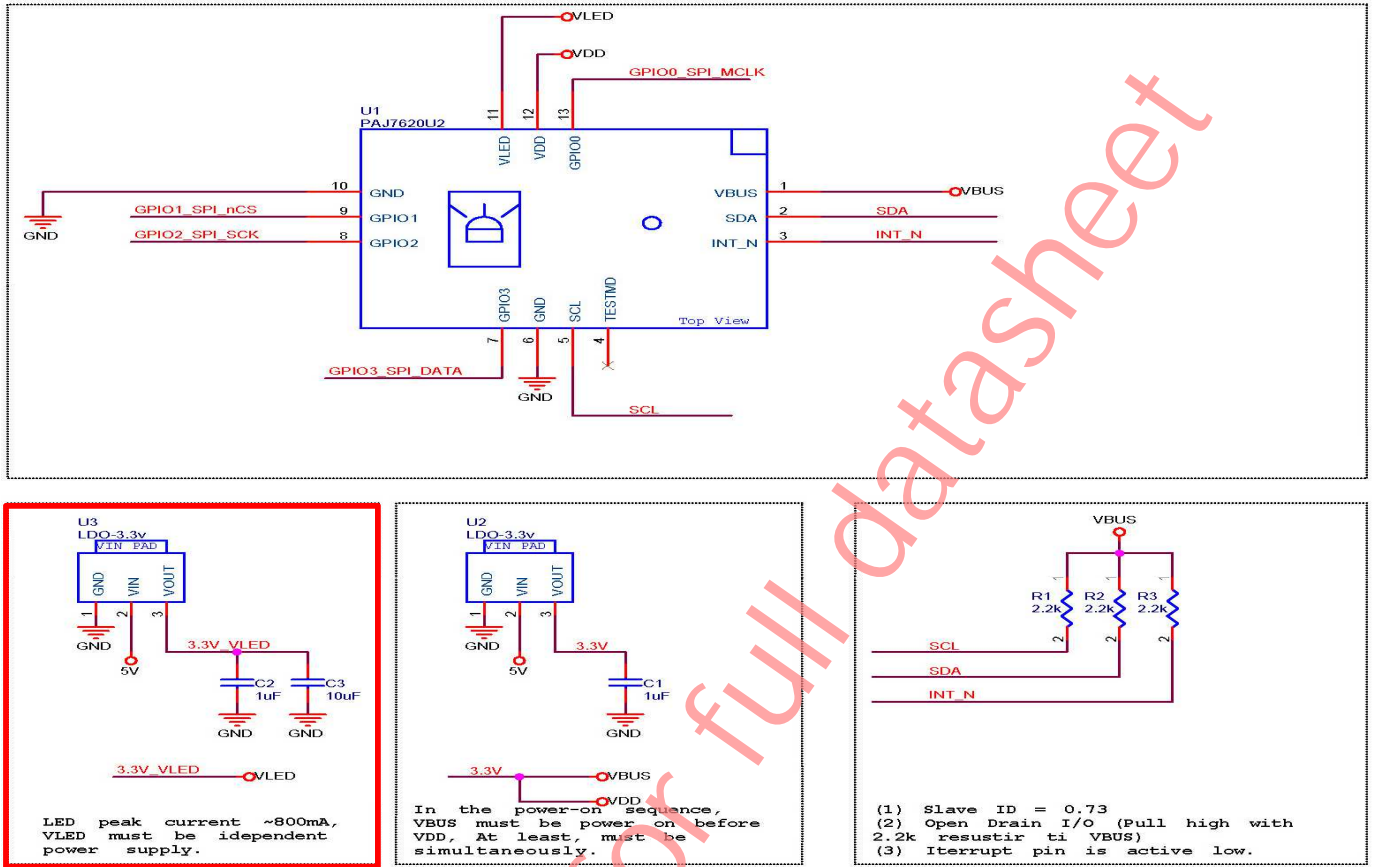

Figure 8. PAJ7620U2 Application Circuit

4.0 Sensor Specifications

4.1 Absolute Maximum Ratings, T_A = 27°C

Parameters	Symbol	Min.	Max.	Unit	Conditions
Supply Voltage	V _{DD}	-	4	V	
LED Supply Voltage	V _{LED}	-	4.6	V	
LED Pulse Current	I _{LED}	-	2	A	Pulse Width < 500us, Duty Cycle < 5%
I ² C Pin, INT_N Pin Voltage	V _{BUS}	-0.3	V _{DD} +0.3	V	SCL, SDA, INT_N
I ² C Pin, INT_N Pin Current	I _{BUS}	-	10	mA	SCL, SDA, INT_N
I/O Pin Voltage	V _{DDIO}	-0.3	V _{DD} +0.3	V	SPIM_CLK, SPI_SCK, SPI_DATA, SPI_nCS
I/O Pin Current	I _{DDIO}	-	10	mA	SPIM_CLK, SPI_SCK, SPI_DATA, SPI_nCS
ESD, human body model	ESD _{HBM}	-	2	kV	
ESD, Machine model	ESD _{MM}	-	200	V	

Notes:

1. Maximum Ratings are those values beyond which damage to the device may occur.
2. Exposure to these conditions or conditions beyond those indicated may adversely affect device reliability.
3. Functional operation under absolute maximum-rated conditions is not implied. Functional operation should be restricted to the Recommended Operating Conditions.

4.2 Recommended Operating Condition

Parameters	Symbol	Min.	Typ.	Max.	Unit	Conditions
Supply Voltage	V _{DD}	2.8	-	3.6	V	
LED Supply Voltage	V _{LED}	3	-	4.2	V	
Peak LED Driver 1/ 2 Current Pulse	I _{LED}	-	360	430	mA	Pulse Width < 500us, Duty Cycle < 5%
I ² C Pin, INT_N Pin Voltage	V _{BUS}	1.8	-	3.3	V	SCL, SDA, INT_N
I ² C Pin, INT_N Pin Current	I _{BUS}	-	-	5	mA	SCL, SDA, INT_N
I/O Pin Voltage	V _{DDIO}	1.8	-	3.3	V	SPIM_CLK, SPI_SCK, SPI_DATA, SPI_nCS
I/O Pin Current	I _{DDIO}	-	-	5	mA	SPIM_CLK, SPI_SCK, SPI_DATA, SPI_nCS
Frequency of external SPI clock input	Frame subtraction mode	22	-	48	MHz	*If using EXT CLK En=1 and EXT CLK IN = 4 MHz
	Raw data mode	44 or 22*	-	48		
Operating Temperature	T _{op}	-40	-	85	°C	
Storage Temperature	T _{storage}	-40	-	125	°C	

4.3 Electrical Specifications, V_{DD}=2.8V, T_A = 27°C

Parameters		Symbol	Min.	Typ.	Max.	Unit	Conditions
Supply Voltage		V _{DD}	2.8	-	3.6	V	
LED Supply Voltage		V _{LED}	3.0	-	4.2	V	LED Supply Voltage
I ² C, INT_N Pin Pull-up Voltage		V _{BUS}	1.8	-	3.3	V	
Current Consumption for Operation Modes	PAJ7620U2	I _{DD}	-	2.82	-	mA	Under Normal Mode. Including LED current (Peak = 760mA)
	Average Mode	I _{DD_Avg_Mode}	-	1	-	mA	Excluding IR LED. 120Hz report rate. 2x2 pixel average mode
	Skip Mode	I _{DD_Skip_Mode}	-	0.8	-	mA	Excluding IR LED. 120Hz report rate. 2x skip mode
Suspend Current		I _{DD_SUS}	-	15	-	μA	
Current Consumption for Standby State 1		I _{DD_ST1}	-	2.3	-	mA	Refer to Operating Principle
Current Consumption for Standby State 2		I _{DD_ST2}	-	1.5	-	mA	1. Under Normal Mode 2. S ₁ , Response Factor =0.5 3. S ₂ , Response Factor =0.25 4. Including LED current @ Peak = 760mA
Current Consumption for Proximity Detection		I _{PS}		0.2		mA	1. Detecting Rate = 10Hz 2. LED peak current = 600mA 3. LED on time = 6.8μs
I ² C Bus Input High Voltage		V _{IH_I2C}	0.7* V _{BUS}		V _{BUS} +0.3	V	
I ² C Bus Input Low Voltage		V _{IL_I2C}	-0.3		0.3* V _{BUS}	V	
Output Low Voltage		V _{OL_SDA} V _{OL_INT_N}	-		0.1* V _{BUS}	V	For INT_N, SDA
I/O Input High Voltage		V _{IH}	0.7* V _{DDIO}	-	V _{DDIO} +0.3	V	
I/O Input Low Voltage		V _{IL}	-0.3	-	0.2* V _{DDIO}	V	
I/O Output High Voltage		V _{OH}	V _{DDIO} - 0.3	-	-	V	
I/O Output Low Voltage		V _{OL}	-	-	0.3	V	

4.4 Gesture Functional Specifications

Parameters	Symbol	Min.	Typ.	Max.	Unit	Condition
Gesture Detecting Range	d _{OP}	5	-	15	cm	Calculated from PAJ7620U2 sensor center
Gesture Detecting View Angle	θ _{OP}	-	60	-	degree	Calculated diagonally
Gesture Speed Response	ω	60		600	degree/s	Angular velocity under Normal Mode
		60		1200		Angular velocity under Gaming Mode
Gesture Update Rate	f _{Update}	-	120	240	Hz	120 Hz for Normal Mode

						240 Hz for Gaming Mode
LED View Angle	$2\theta_{1/2}$		60		degree	
LED Peak Wavelength	λ		940		nm	

4.5 Interface AC Specifications

Parameters	Symbol	Min.	Typ.	Max.	Unit	Conditions
I ² C Speed	S _{I2C}	-	100	400	Kbit/s	
Frequency of External SPI Clock Input		22	-	48	MHz	Frame subtraction mode
		44	-	48	MHz	Raw data mode

please ask for full datasheet

5.0 Serial Interface Communication

5.1 I²C Interface

SDA (serial data) and SCL (serial clock) form a two-wire serial interface compatible with I²C. The PAC7620 is implemented as a slave-only device so it never drives SCL. It drives SDA during (host) read cycles and transmission of the Acknowledge bit. PAC7620 uses 7-bit addressing and does not support clock stretching. The SDA and SCL pins are open-drain structure requiring external pull-up resistors.

- Start and stop condition: SDA high to low transition while SCL is high defines a Start condition. SDA low to high transition while SCL is high defines a Stop condition. (Refer to Figure 99)
- Valid data: The data on SDA line must be stable during high period of SCL. MSB is always transferred first for each byte. LSB of the first byte is Read / Write control bit. (Refer to Figure 1010)
- Both master and slave can transmit and receive data from the bus.
- Acknowledge: The Receiving device should pull down SDA during high period of the 9th clock (SCL) after a complete byte has been received from the transmitter. In the case of the master receiving data from the slave, the master does not generate an Acknowledge bit after the last byte to indicate the end of a master read cycle.

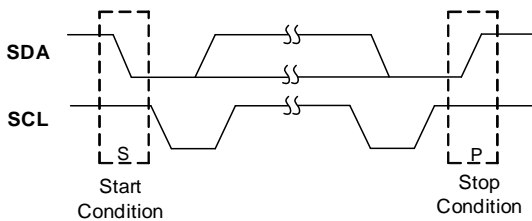

Figure 9. Start and Stop Conditions

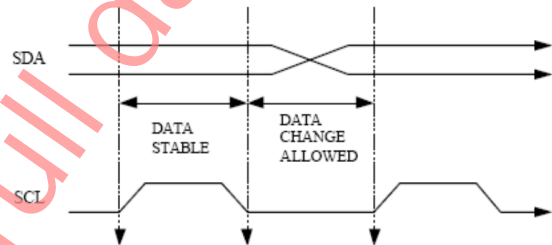

Figure 10. Valid Data

5.1.1 I²C Protocol

The I²C Slave ID is using 7 bit addressing protocol: 0x13, 0x1B, 0x23, 0x2B, 0x5B, 0x63, 0x6B, 0x73 and default is 0x73.

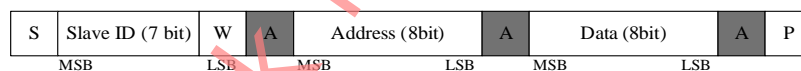

Figure 11. Single Write Protocol

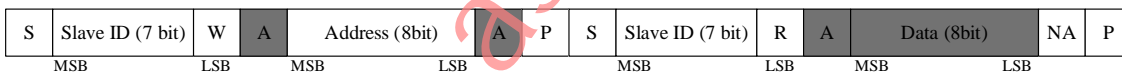

Figure 12. Single Read Protocol

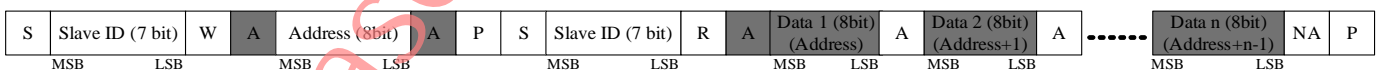

Figure 13. Burst Read Protocol

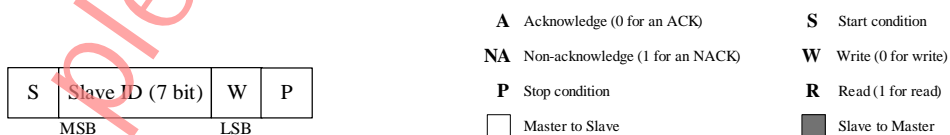

Figure 14. I²C Wake-up command Protocol

5.1.2 I²C Timing Parameter

Parameter	Symbol	STANDARD MODE		FAST MODE		Unit
		Min.	Max.	Min.	Max.	
SCL clock frequency.	f_{scl}	10	100	10	400	kHz
Hold time for Start/Repeat Start. After this period, the first clock pulse is generated.	$t_{HD.STA}$	4		0.6		μs
Set-up time for a repeated Start.	$t_{SU.STA}$	4.7		0.6		μs
Low period of SCL clock.	t_{LOW}	4.7		1.3		μs
High period of SCL clock.	t_{HIGH}	4		0.6		μs
Data hold time.	$t_{HD.DAT}$	0		0		μs
Data set-up time.	$t_{SU.DAT}$	250		100		ns
Rise time of both SDA and SCL signals.	t_r		1000	-	300	ns
Fall time of both SDA and SCL signals.	t_f		300	-	300	ns
Set-up time for STOP condition.	$t_{SU.STO}$	4		0.6		μs
Bus free time between a STOP and START.	t_{BUF}	4.7		1.3		μs

Note: Maximum current is 5mA and capacitance load spec. =100pF

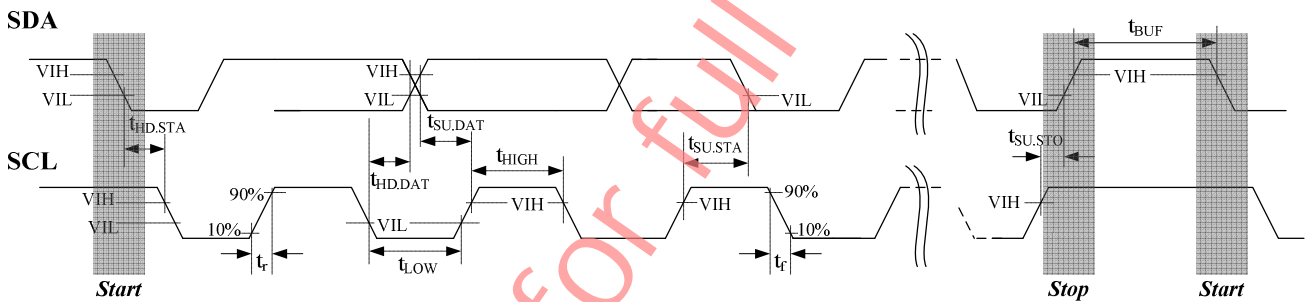
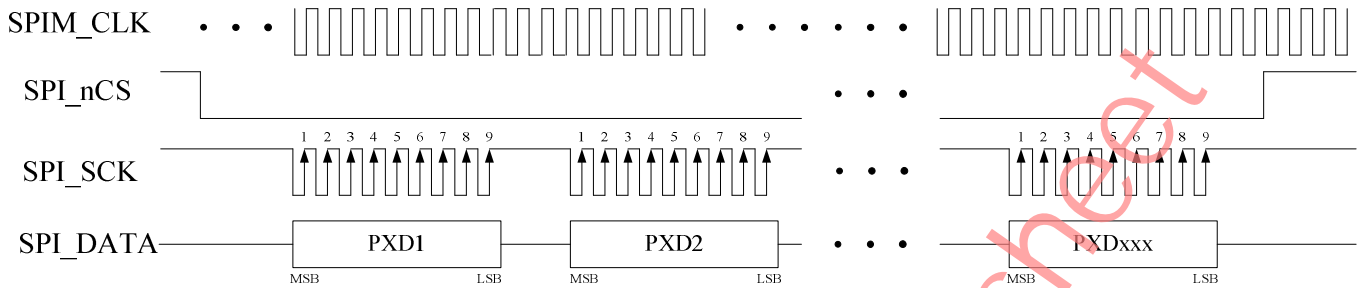

Figure 15. I²C Timing Diagram

5.2 Four-Wire SPI Interface (For Image Mode Only)

5.2.1 SPI Master Protocol



Notes: xxx = 900 for 30x30 (Frame subtraction mode), =3600 for 60x60 (Raw data mode)

Figure 16. SPI Master Protocol

5.2.2 SPI Timing Parameter

Parameter	Symbol	Typ. (measured)	Unit
SCK clock frequency, ($f_{sck} = 1/t_p$)	f_{sck}	24	MHz
Low period of SCK clock.	t_{LOW}	15.5	ns
High period of SCK clock.	t_{HIGH}	12.5	
Data output valid time.	$t_{V(MO)}$	20.3	
Data output hold time.	$t_{H(MO)}$	20.8	
Rise time of SCK clock	t_r	8	
Fall time of SCK clock	t_f	8	

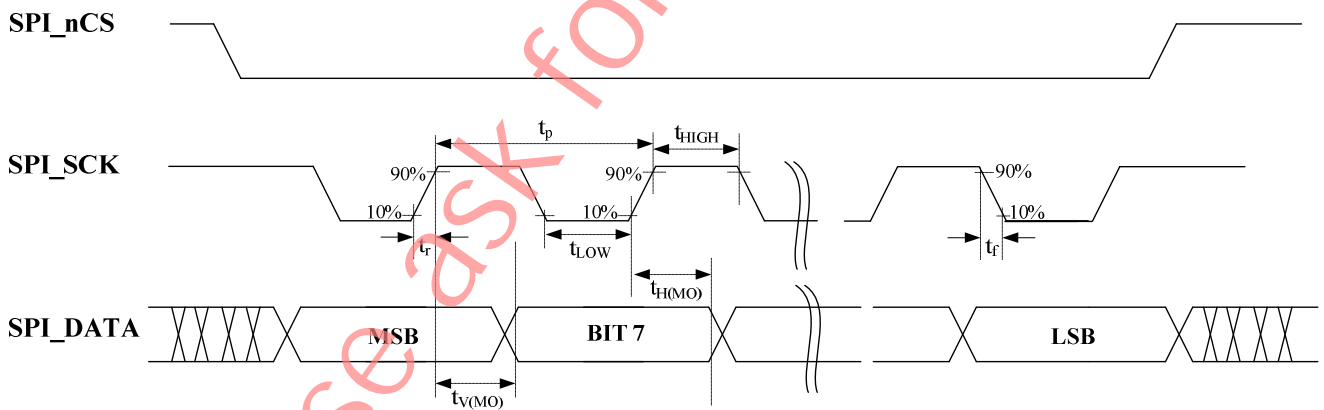

Figure 17. SPI Timing Diagram

6.0 Operation Principles

6.1 Gesture mode

6.1.1 Module Orientation

The sensor module package should be placed in the correct orientation to have the gesture direction as per **錯誤! 找不到參照來源** 18.

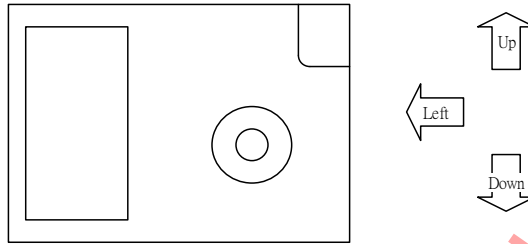

Figure 18. Module Orientation of PAJ7620U2 (Front View)

If the sensor module package is rotated to a different angle, the direction of gesture detection interrupt flag mask (Register Bank 0, ADDR 0x41) and gesture detection interrupt flag (Register Bank 0, ADDR 0x43) needs to be re-mapped.

Bank	Address	Register Name	Default Value	R/W	Description
0	0x41	R_Int_1_En	0xFF	R/W	Interrupt flag mask control. Bit[7] Counter-Clockwise Mask Bit[6] Clockwise Mask Bit[5] Backward Mask Bit[4] Forward Mask Bit[3] Up Mask Bit[2] Down Mask Bit[1] Right Mask Bit[0] Left Mask
0	0x43	IntFlag_1	0x00	R/W	Interrupt flag. Bit[7] Counter-Clockwise Bit[6] Clockwise Bit[5] Backward Bit[4] Forward Bit[3] Up Bit[2] Down Bit[1] Right Bit[0] Left

6.1.2 Power-On Sequence

In the power-on sequence, The V_{BUS} Must be power on before V_{DD} . After power on, wait $T_1 \mu s$ for PAJ7620U2 to stabilize and then write slave ID (0x73) to process I²C wake-up (Refer to topic "I²C Interface"). After $T_2 \mu s$, write the initial settings and the different modes settings to PAJ7620U2. Lastly, enable PAJ7620U2 by writing Register Bank1, Addr0x72 with 0x01. The gesture data can now be accessed through the I²C bus.

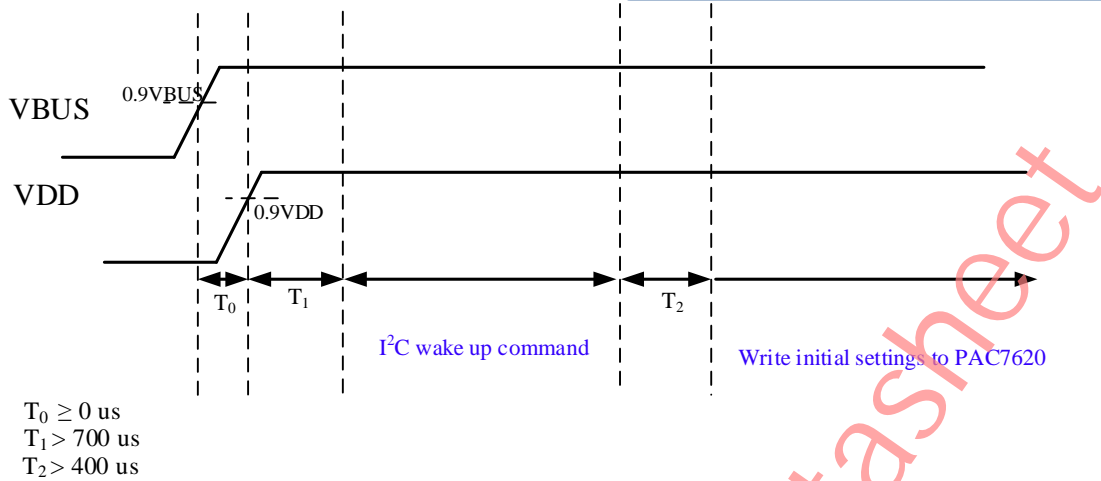

Figure 19. PAJ7620U2 Power-On Timing Diagram

6.1.3 Gesture Detection Operating State

6.1.3.1 Operation State (OP state)

When in operation state, the gesture update rate is 120Hz for Normal Mode and 240Hz for Gaming Mode respectively. The gesture result can be accessed by interrupt mechanism or continuous polling the gesture detection interrupt flag (Register Bank 0, Addr0x43).

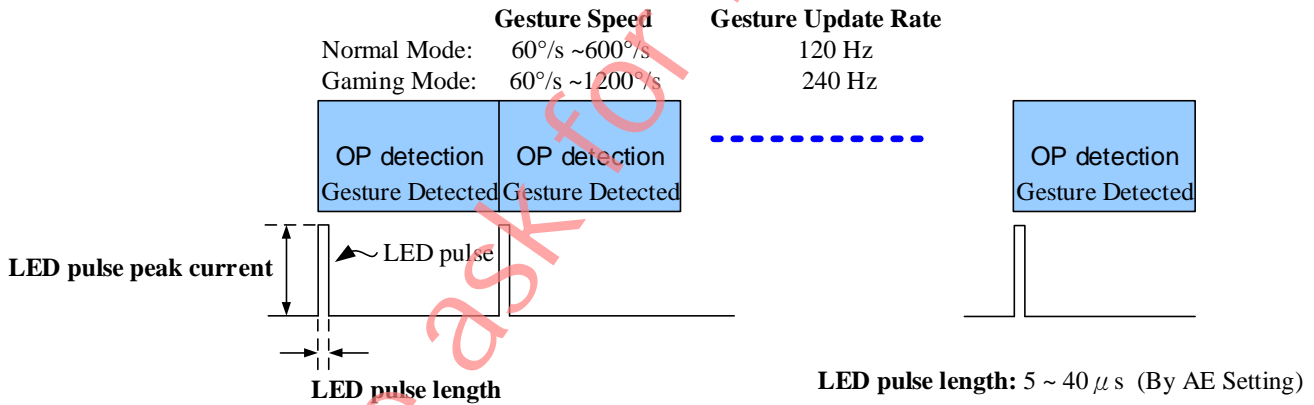

Figure 20. Operation State (OP state) Diagram

6.1.3.2 Standby 1 State (S1 state)

When in Standby1 state the object detection rate equals $S_{1, \text{Response Factor}}$ multiply the gesture update rate of Normal Mode or Gaming Mode.

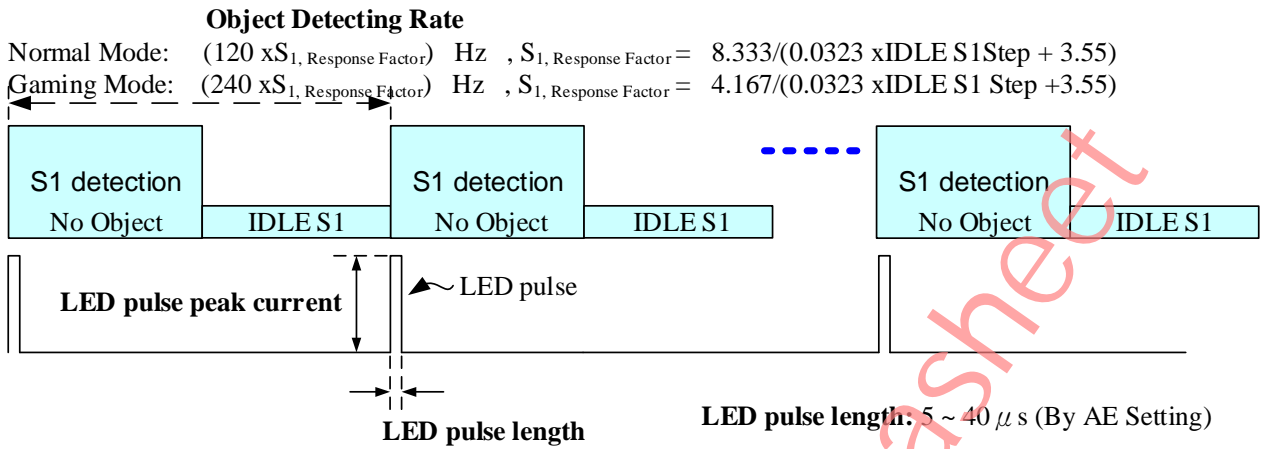

Figure 21. Standby 1 State (S1 state) Diagram

6.1.3.3 Standby 2 State (S2 state)

When in Standby 2 state, the object detection rate equals $S_{2, \text{Response Factor}}$ multiply the gesture update rate of Normal Mode or Gaming Mode.

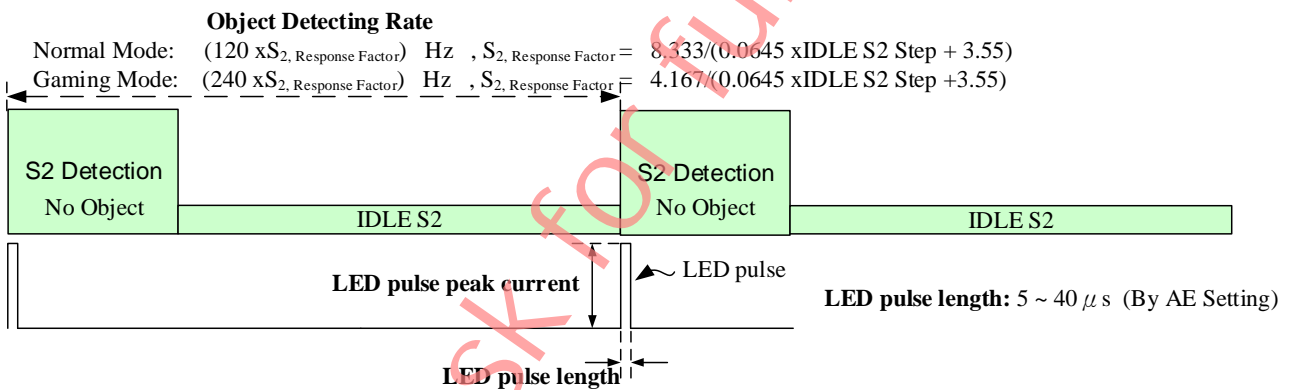

Figure 22. Standby 2 State (S2 state) Diagram

6.1.3.4 Suspend State (SUS state)

To enter the suspend state, first disable the PAC7620 by writing Register Bank 1, ADDR 0x72 with 0x00 then process the I²C suspend command by writing Register Bank 0, ADDR 0x03 with 0x01.

To exit the suspend state, first process the I²C wake-up command by writing the slave ID (Refer to topic "I²C Bus Timing Characteristics and Protocol") then enable the PAC7620 by writing Register Bank 1, ADDR 0x72 with 0x01.

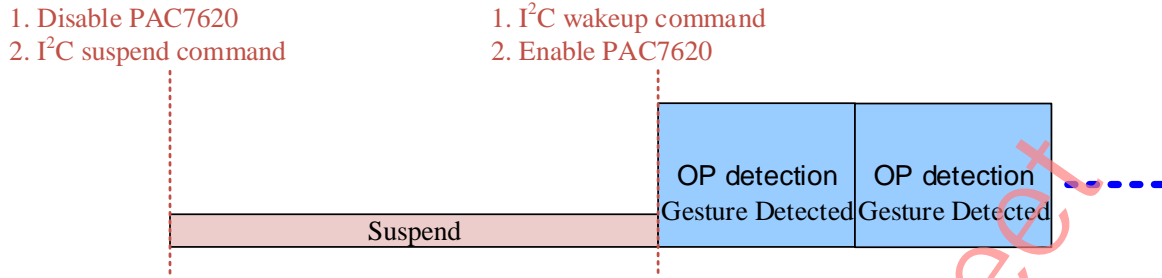
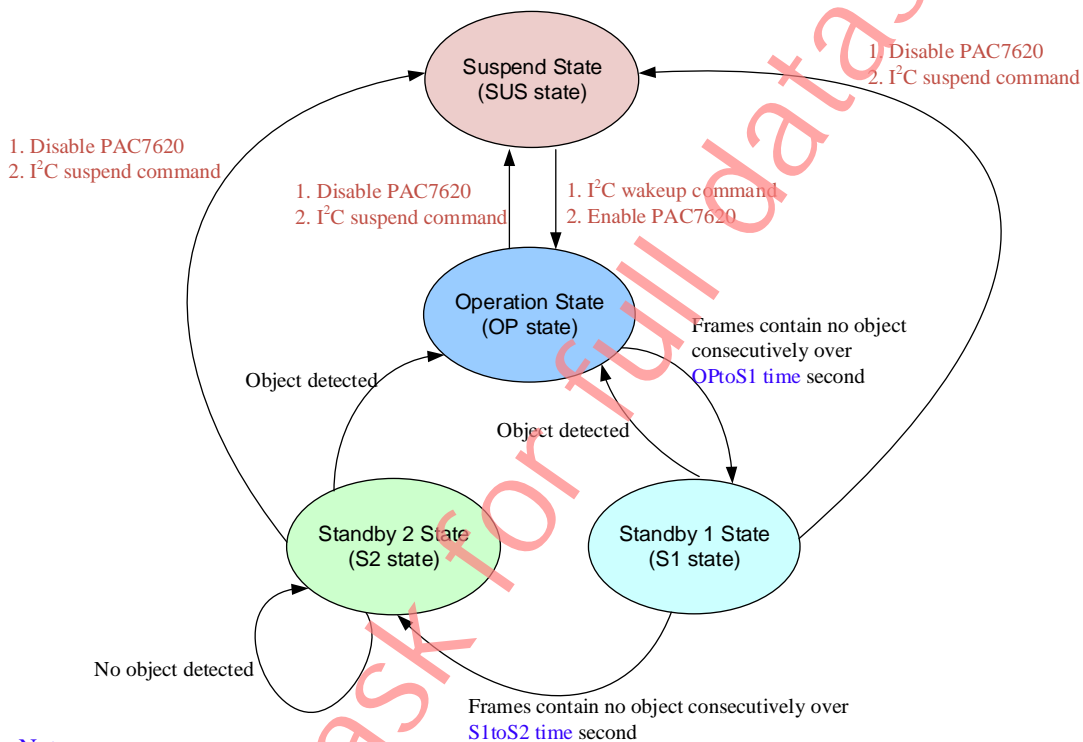

Figure 23. Suspend State (SUS state) Diagram

6.1.3.5 State Machine



Note:

$OPtoS1\ time = OPtoS1\ step / 120 @\ Normal\ Mode$
 $= OPtoS1\ step / 240 @\ Gaming\ Mode$

$S1toS2\ time = S1toS2\ step / (60 \times S_{1, Response\ Factor}) @\ Normal\ Mode$
 $= S1toS2\ step / (120 \times S_{1, Response\ Factor}) @\ Gaming\ Mode$

Figure 24. State Machine of Gesture Detection

6.2 Image mode

6.2.1 Output Image Timing

6.2.1.1 30x30, Frame Subtraction Mode

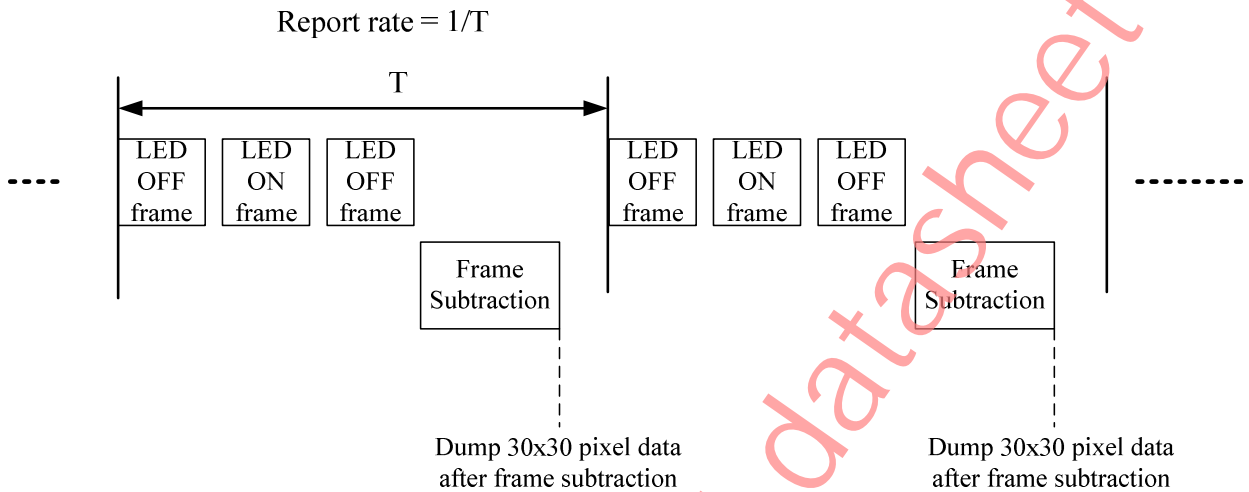

Figure 25. Timing of Output Image for 30x30 pixels

6.2.1.2 60x60, Raw Data Mode

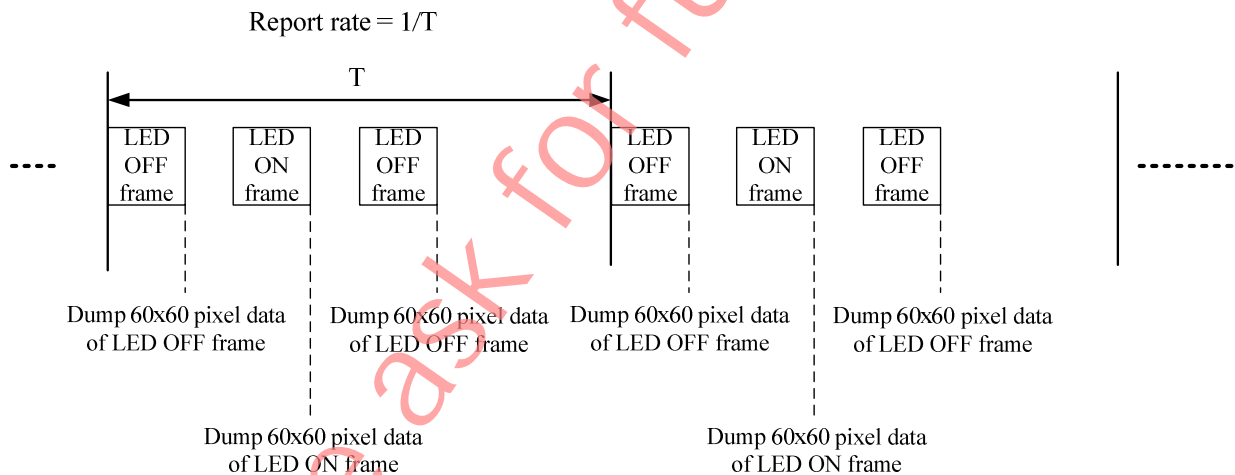

Figure 26. Timing of Output Image for 60x60 pixels

6.2.2 Suspend State

To enter the suspend state, first disable the SPI output by writing Register Bank 1, ADDR 0x7E with 0x00. Second, disable the PAC7620 by writing Register Bank 1, ADDR 0x72 with 0x00 then process the I²C suspend command by writing Register Bank 0, ADDR 0x03 with 0x00.

To exit the suspend state, first process the I²C wake-up command by writing the slave ID (Refer to topic "I²C Interface"). Second, enable the PAC7620 by writing Register Bank 1, ADDR 0x72 with 0x01 then enable the SPI output by writing Register Bank 1, ADDR 0x7E with 0x01.

- 1. Disable SPI output (for Image Mode Only)
- 2. Disable PAC7620
- 3. I²C suspend command

- 1. I²C wakeup command
- 2. Enable PAC7620
- 3. Enable SPI output (For Image Mode Only)

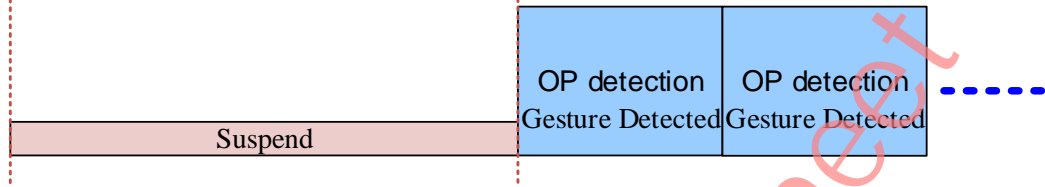

Figure 27. Suspend State (SUS state) Diagram

6.3 Proximity Detection Mode

Refer to Figure 2828 on how to set the Proximity Sensing (PS) hysteresis window and the interrupt mechanism of proximity detection.

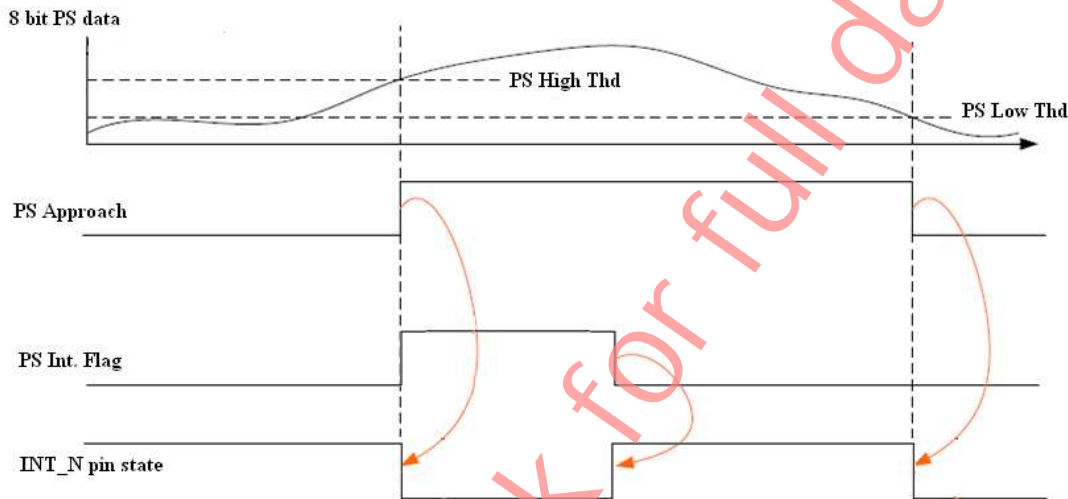

Figure 28. Proximity Sensing Functional Diagram

6.3.1 Proximity Detection Operating State

6.3.1.1 Proximity Operation State (PS OP state)

When in operation state, the update rate is 10Hz and the LED on time is 8μs. The LED peak current is 760 mA.

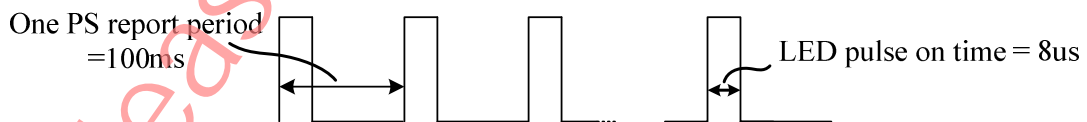

Figure 29. Proximity Operation State (PS OP state) Diagram

6.3.1.2 Suspend State (SUS state)

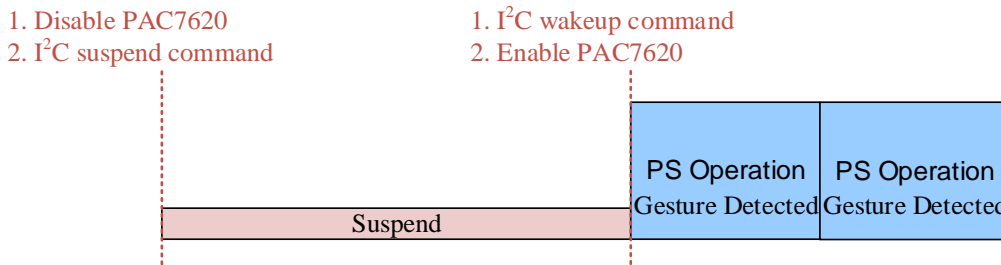

Figure 30. Suspend State (SUS state) Diagram

6.3.1.3 State Machine

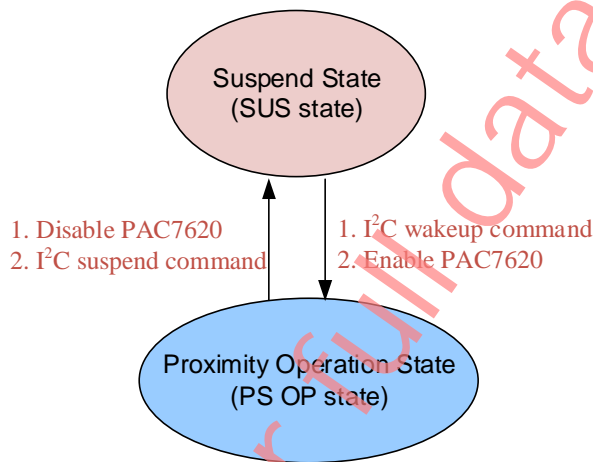

Figure 31. State Machine of Proximity Detection

7.0 Register Tables

7.1 Register Bank Select

Bank	Address	Register Name	Default Value	R/W	Description
0/1	0xEF	R_RegBankSel[0]	0x00	R/W	Register Bank Select. 0 : Register Bank 0 1 : Register Bank 1
1	0x7F	R_RegBankSel[0]	0x00	R/W	Register Bank Select. 0 : Register Bank 0 1 : Register Bank 1

7.2 Image Size Setting

Bank	Address	Register Name	Default Value	R/W	Description
0	0xAA	R_ImageHeight[5:0]	0x1E	R/W	DSP image vertical size
0	0xAB	R_ImageWidth[5:0]	0x1E	R/W	DSP image horizontal size
1	0x00	Cmd_HSize[5:0]	0x1E	R/W	Horizontal size
1	0x01	Cmd_VSize[5:0]	0x1E	R/W	Vertical size
1	0x02	Cmd_HStart[5:0]	0x00	R/W	Horizontal start point
1	0x03	Cmd_VStart[5:0]	0x00	R/W	Vertical start point
1	0x04	Cmd_ASkip_V[5]	0x01	R/W	Analog vertical skip
1	0x04	Cmd_ASkip_H[4]	0x01	R/W	Analog horizontal skip
1	0x04	Cmd_DAvg_V[3]	0x00	R/W	Digital vertical average
1	0x04	Cmd_VFlip[1]	0x00	R/W	Vertical flip
1	0x04	Cmd_HFlip[0]	0x00	R/W	Horizontal flip

7.3 Setting 30x30 Pixels Image Output Mode

Bank	Address	Bit	2x skip mode	2x2 average mode	WOI mode
0	0xAA	5:0	30	30	30
0	0xAB	5:0	30	30	30
1	0x00	5:0	30	30	30
1	0x01	5:0	30	60	30
1	0x02	5:0	0	0	15
1	0x03	5:0	0	0	15
1	0x04	7	0	1	0
1		6	0	0	0
1		5	1	0	0
1		4	1	1	0
1		3	0	1	0
1		2	0	0	0