

Messrs.

CONDUCTIVE POLYMER ALUMINUM SOLID ELECTROLYTIC CAPACITORS SPECIFICATION SHEET

RoHS/Pb Free Compliance

CUSTOMER PART No.		
Rubycon PART No.	PHV SERIES	
DRAWING No.	REE - 0P0256	ISSUE No. 1
ISSUE DATE	24 November 2016	



RUBYCON CORPORATION ENGINEERING DIVISION
ELECTROLYTIC CAPACITOR DESIGN DEPT.
1938-1, NISHIMINOWA, INA-SHI, NAGANO-KEN, JAPAN
TEL No. +81-265-72-6209 FAX
No. +81-265-72-7739

PREPARED	YUICHI KOBAYASHI
CHECK	TETSUYA MIZU
APPROVAL	YOSHINORI SASAKI

1. Scope.

This specification covers polarized conductive polymer aluminum solid electrolytic capacitors for use in electronic equipments.

2. Conformance Standard

- IEC 60384-1(JIS C 5101-1) Fixed capacitors for use in electronic equipment – Part 1: Generic Specification
- IEC60384-25(JIS C 5101-25) Fixed capacitors for use in electronic equipment – Part 25: Sectional specification–Surface mount fixed aluminum electrolytic capacitors with conductive polymer solid electrolyte.
- JEITA RCR-2367C Safety Application Guide for fixed aluminum electrolytic capacitors for use in electronic equipment.
- AEC-Q200 Stress test qualification for passive components.

3. Category Temperature Range
: -55°C to +135°C

4. Performance Reference to Table-1

5. Style Surface mount (CA 32)

6. Marking

(1) Marking at the body

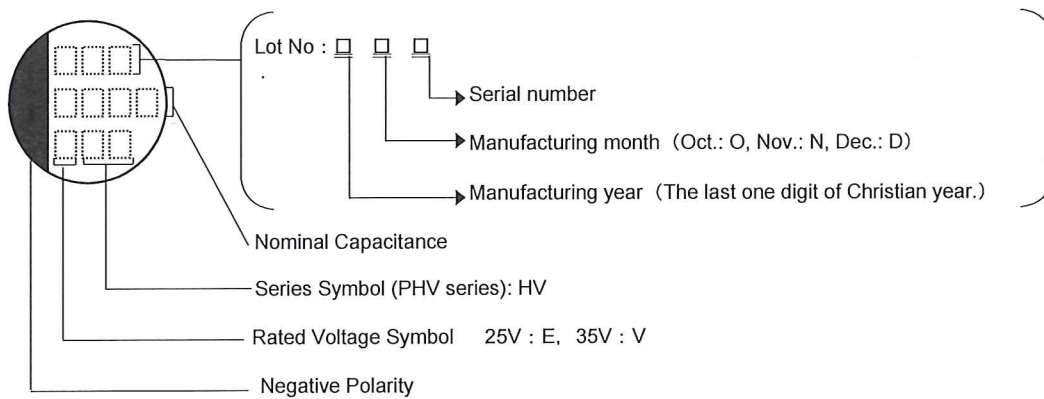

Color of marking : Purple

(2) Part Numbering System

*Rubycon Numbering System

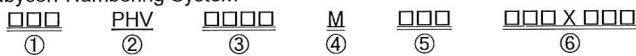

- ① Rated Voltage (Direct number of voltage)
- ② Series
- ③ Nominal Capacitance (Direct number of capacitance)
- ④ Tolerance of capacitance (Code for tolerance of capacitance, e.g. "M" for ±20%)
- ⑤ Option
- ⑥ Case size/case code (Direct number of dimensions, φD X L, or designated case code)

7. Notes on use of aluminum electrolytic capacitors

(1) Charge and discharge

Do not use for the circuit that repeats quick charge or discharge

Capacitors shall withstand the following inrush current

< Inrush current >
10A Max

(2) Polarity

- This capacitor has polarity.
- Please confirm the polarity before use.

(3) External stress

Do not apply excessive force of pushing, pulling bending, and/or twisting to the main body, lead wire and terminals.

(4) Insulation

Case and cathode terminal are not insulated.

(5) Adhesives and coating materials

Do not use the adhesives and coating materials that contain halogenated organic solvents or chloroprene as polymer.

Do not cover up all the sealing area of capacitors with adhesives or moisture prevention coating materials.

(6) Fumigation and halogenated flame retardant

It may cause corrosion of internal electrodes, aluminum cases and terminal surface when the following conditions exist.

- Fumigation of wooden pallets before shipment to disinfect vermin.
- Existence of components or parts that contain halogenated flame retardant agent (bromine etc.) together with capacitors.
- When halogenated detergents or antiseptics for preventing infection of epidemic diseases contact directly to capacitors.

(7) PC board cleaning after soldering

Please consult us when cleaning is subjected.

Guide to application expect the above are described in EIAJ RCR -2367C
EIAJ RCR -2367C : "Safety Application Guide for fixed aluminum electrolytic capacitors for use in electronic equipment"
Published by Japan Electronics and Information Technology Industries Association

8. Storage

Keep at a normal temperature and humidity. During a long storage time, leakage current will be increased. To prevent heat rise or any trouble that high leakage current possibly causes, voltage treatment is recommended for the capacitors that have been stored for a long time.

After a long time period storage, it is recommended to check solderability of the capacitor before production as surface of lead wire terminal may have been oxidized and cause a problem.

<Storage Condition>

- Aluminum Electrolytic Capacitors with conductive polymer should not be stored in high temperatures or where there is a high level of humidity. The suitable storage condition is 5 to 35°C and less than 75% in relative humidity.
- Aluminum Electrolytic Capacitors with conductive polymer should not be stored in damp condition such as water, saltwater spray or oil spray.
- Do not store Aluminum Electrolytic Capacitors with conductive polymer in an environment full of hazardous gas (hydrogen sulfide, sulfuric acid gas, nitrous acid, chlorine gas or ammonia, etc).
- Aluminum Electrolytic Capacitors with conductive polymer should not be stored under exposure to ozone, ultraviolet rays or radiation.

<Voltage treatment>

The capacitor should be serially attached to a protective resistor ranging from 10 to 1000Ω and d.c. voltage equivalent to the rated voltage should be applied for 2 hours at 105±2°C.

Next, after letting the capacitor cool to room temperature, it should be discharged through a resistor of approximately 1Ω/V and then stored at standard atmospheric conditions for 1 to 2 hours.

9. Storage time limit

1 year after forward

10. Term

Standard atmospheric conditions (JIS C 5101-1) :

- temperature: 15 °C to 35 °C
- relative humidity: 25 % to 75 %
- air pressure: 86 kPa to 106 kPa

◆Table-1 PERFORMANCE

ITEMS		PERFORMANCE								
1	Rated Voltage(WV) Surge Voltage (SV)	<table border="1"> <tr> <td>WV [V.d.c.]</td> <td>25</td> <td>35</td> </tr> <tr> <td>SV [V.d.c.]</td> <td>29</td> <td>40</td> </tr> </table>	WV [V.d.c.]	25	35	SV [V.d.c.]	29	40		
WV [V.d.c.]	25	35								
SV [V.d.c.]	29	40								
2	Capacitance (Tolerance)	<p><Condition></p> <table border="1"> <tr> <td>Measuring Frequency</td> <td>: 120Hz±20%</td> </tr> <tr> <td>Measuring Voltage</td> <td>: Not more than 0.5Vrms (Note 1)</td> </tr> <tr> <td>Measuring Temperature</td> <td>: 20 ± 2 °C</td> </tr> </table> <p>(Note 1) A d.c. bias voltage of 1.5 to 2.0 Vd.c. may be applied during the measurement.</p> <p><Criteria></p> <p>Within ±20% from nominal capacitance value specified in Table-2.</p>			Measuring Frequency	: 120Hz±20%	Measuring Voltage	: Not more than 0.5Vrms (Note 1)	Measuring Temperature	: 20 ± 2 °C
Measuring Frequency	: 120Hz±20%									
Measuring Voltage	: Not more than 0.5Vrms (Note 1)									
Measuring Temperature	: 20 ± 2 °C									
3	Leakage Current	<p><Condition></p> <p>The rated voltage shall be applied between terminals of capacitor such that the terminal voltage will reach the rated voltage Within one minute and the leakage current shall be measured at 2 minutes after the voltage has reached the rated voltage across a 1000 ±10 Ω series protection resistor. (20±2°C)</p> <p><Criteria></p> <p>The value is shown in "Table-2 Electrical specifications".</p> <p><Notice></p> <p>* If any doubt arises on the judgment (ex. When the leakage current may be increased), the capacitors should be applied with voltage treatment. See [8.Storage <Voltage treatment>]</p>								
4	Dissipation Factor (tanδ:Tangent of loss angle)	<p><Condition></p> <p>See ITEM 2, Capacitance, for measuring frequency, voltage and temperature.</p> <p><Criteria></p> <p>Dissipation Factor is not more than the values of Table-2.</p>								

5	ESR	<p><Condition></p> <div style="border-left: 1px solid black; border-right: 1px solid black; padding: 5px;"> <p>Measuring Frequency : 100 [kHz] ± 10 [kHz] 、 Measuring Voltage : Not more than 0.5Vrms Measuring Temperature : 20 ± 2 °C</p> </div> <p><Criteria></p> <p>ESR in frequency range of 100kHz is not more than the values of Table-2.</p>
---	-----	--

6	Surge Voltage	<p>< Condition ></p> <p>The capacitor shall be applied surge voltage through a 1kΩ resistor in series for 30±5 seconds in every 6±0.5 minutes at 15 to 35°C. The procedure shall be repeated 1000 times. Then the capacitors shall be recovered at standard atmospheric conditions (See 10.) for 1 to 2 hours before measurement. (If any doubt arises on the judgment, the capacitors shall be subjected to voltage treatment. See [8.Storage <Voltage treatment>])</p> <p><Criteria></p> <table border="1" data-bbox="539 862 1423 1041"> <tr> <td>Leakage Current</td> <td>Not more than the values of Table-2</td> </tr> <tr> <td>Capacitance Change</td> <td>Within ±15% of the initial value</td> </tr> <tr> <td>Dissipation Factor</td> <td>Not more than the values of Table-2</td> </tr> <tr> <td>ESR</td> <td>Not more than the values of Table-2</td> </tr> <tr> <td>Appearance</td> <td>Notable changes shall not be found</td> </tr> </table> <p>※This item provides for overvoltage at abnormal situations, and not be hypothesizing that overvoltage is always applied.</p>	Leakage Current	Not more than the values of Table-2	Capacitance Change	Within ±15% of the initial value	Dissipation Factor	Not more than the values of Table-2	ESR	Not more than the values of Table-2	Appearance	Notable changes shall not be found
Leakage Current	Not more than the values of Table-2											
Capacitance Change	Within ±15% of the initial value											
Dissipation Factor	Not more than the values of Table-2											
ESR	Not more than the values of Table-2											
Appearance	Notable changes shall not be found											

7 Characteristics at high and low Temperature

< Condition >

STEP	Testing Temperature (°C)	Time
1	20±2	Time to reach thermal equilibrium
2	-55±3	//
3	-25±3	//
4	20±2	//
5	135±2	2hrs
6	20±2	Time to reach thermal equilibrium

Capacitance, D.F. shall be measured at 120Hz.
ESR · Impedance shall be measured at 100kHz.

< Criteria >

STEP 2	Impedance Ratio	Ratio of the value in STEP2 and STEP 1 is less than value of 2.0
	ESR	Not more than 200% of the values of Table-2
STEP 3	Impedance Ratio	Ratio of the value in STEP3 and STEP 1 is less than value of 1.5
STEP 5	ESR	Not more than 200% of the values of Table-2
	Leakage Current	Not more than 12.5 times the values of Table-2
STEP 6	Capacitance Change	Within ±5% of the value of STEP 1
	Dissipation Factor	Not more than the values of Table-2
	ESR	Not more than the values of Table-2
	Leakage Current	Not more than the values of Table-2

8 Endurance

< Condition >

Capacitor shall be applied the DC voltage through 1000ohm series protective resistor with rated ripple current at each temperature for following test period.

Temperature	Life Time (hrs)
125±2°C	4000 ⁺⁷² ₀
135±2°C	

The sum of DC voltage and ripple peak voltage shall be equal to rated voltage or less.

After the test and returned in standard atmospheric conditions for 1 to 2 hours, and the capacitor shall meet the following requirements.

< Criteria >

Leakage Current	Not more than the values of Table-2
Capacitance Change	Within ±30% of the initial value
Dissipation Factor	Not more than 200% of the values of Table-2
ESR	Not more than 200% of the values of Table-2
Appearance	Notable changes shall not be found

9	Over temperature proof	<p><Condition></p> <p>Capacitor under test shall be applied the rated voltage continuously through 1000 ohm series protective resistor at 150±2°C. After 300 +24/0 hours, capacitor shall be stored in standard condition for 2 hours or more, and the capacitor shall meet following requirements.</p> <p><Criteria></p> <table border="1" data-bbox="552 524 1430 703"> <tr> <td>Leakage Current</td> <td>Not more than the values of Table-2</td> </tr> <tr> <td>Capacitance Change</td> <td>Within ±30% of the initial value</td> </tr> <tr> <td>Dissipation Factor</td> <td>Not more than 200% of the values of Table-2</td> </tr> <tr> <td>ESR</td> <td>Not more than 200% of the values of Table-2</td> </tr> <tr> <td>Appearance</td> <td>Notable changes shall not be found</td> </tr> </table>	Leakage Current	Not more than the values of Table-2	Capacitance Change	Within ±30% of the initial value	Dissipation Factor	Not more than 200% of the values of Table-2	ESR	Not more than 200% of the values of Table-2	Appearance	Notable changes shall not be found		
Leakage Current	Not more than the values of Table-2													
Capacitance Change	Within ±30% of the initial value													
Dissipation Factor	Not more than 200% of the values of Table-2													
ESR	Not more than 200% of the values of Table-2													
Appearance	Notable changes shall not be found													
10	Storage at high Temperature	<p>< Condition ></p> <p>Capacitors shall be stored at 135±2°C for a period of 1000 ±24 hours with no voltage applied. After the test, returned in standard atmospheric conditions for 1 to 2 hours and the capacitor shall meet following requirements. (If any doubt arises on the judgment, the capacitors shall be subjected to voltage treatment. See [8.Storage <Voltage treatment>])</p> <p>< Criteria ></p> <table border="1" data-bbox="552 978 1430 1158"> <tr> <td>Leakage Current</td> <td>Not more than the values of Table-2</td> </tr> <tr> <td>Capacitance Change</td> <td>Within ±30% of the initial value</td> </tr> <tr> <td>Dissipation Facto</td> <td>Not more than 200% of the values of Table-2</td> </tr> <tr> <td>ESR</td> <td>Not more than 200% of the values of Table-2</td> </tr> <tr> <td>Appearance</td> <td>Notable changes shall not be found</td> </tr> </table>	Leakage Current	Not more than the values of Table-2	Capacitance Change	Within ±30% of the initial value	Dissipation Facto	Not more than 200% of the values of Table-2	ESR	Not more than 200% of the values of Table-2	Appearance	Notable changes shall not be found		
Leakage Current	Not more than the values of Table-2													
Capacitance Change	Within ±30% of the initial value													
Dissipation Facto	Not more than 200% of the values of Table-2													
ESR	Not more than 200% of the values of Table-2													
Appearance	Notable changes shall not be found													
11	Vibration	<p>< Condition></p> <p>The capacitors shall be subjected to sinusoidal vibration with the following severities;</p> <table border="1" data-bbox="533 1301 1321 1435"> <tr> <td>Frequency</td> <td>: 10 to 55Hz</td> </tr> <tr> <td>Amplitude or acceleration</td> <td>: 0.75mm or 100m/s² , whichever is lower acceleration</td> </tr> <tr> <td>Total duration</td> <td>: 6 hours (2 hours for each of three (X, Y and Z) axis)</td> </tr> <tr> <td>Mounting method</td> <td>: according to JIS C 5101-1 4.33</td> </tr> </table> <p>< Criteria ></p> <table border="1" data-bbox="557 1509 1417 1581"> <tr> <td>Capacitance Change</td> <td>Within ±10% of the initial value</td> </tr> <tr> <td>Appearance</td> <td>Notable changes shall not be found</td> </tr> </table>	Frequency	: 10 to 55Hz	Amplitude or acceleration	: 0.75mm or 100m/s ² , whichever is lower acceleration	Total duration	: 6 hours (2 hours for each of three (X, Y and Z) axis)	Mounting method	: according to JIS C 5101-1 4.33	Capacitance Change	Within ±10% of the initial value	Appearance	Notable changes shall not be found
Frequency	: 10 to 55Hz													
Amplitude or acceleration	: 0.75mm or 100m/s ² , whichever is lower acceleration													
Total duration	: 6 hours (2 hours for each of three (X, Y and Z) axis)													
Mounting method	: according to JIS C 5101-1 4.33													
Capacitance Change	Within ±10% of the initial value													
Appearance	Notable changes shall not be found													

12 Resistance to Soldering Heat

< Condition >

Performing soldering reflow profile shown below. Then the capacitors shall be stored under standard atmospheric conditions for 24±2 hours before measurement.
 (If any doubt arises on the judgment, the capacitors shall be subjected to voltage treatment. See [8.Storage <Voltage treatment>])

< Reflow admissibility condition >

- (1) The surface temperature of the capacitor is less than T°C.
- (2) In the reflow profile, the time of 200°C or more must not exceed t second, and the time of 230°C or more must not exceed t1 second of the following table.
- (3) Stay at peak temperature may be less than 5 seconds.
- (4) Preheat shall be made at 100°C to 180°C and for maximum 120 seconds.
- (5) The number of times of reflow should be performed reflow number of following table.
- (6) Please ensure that the capacitor became cold enough to the room temperature before the second reflow.

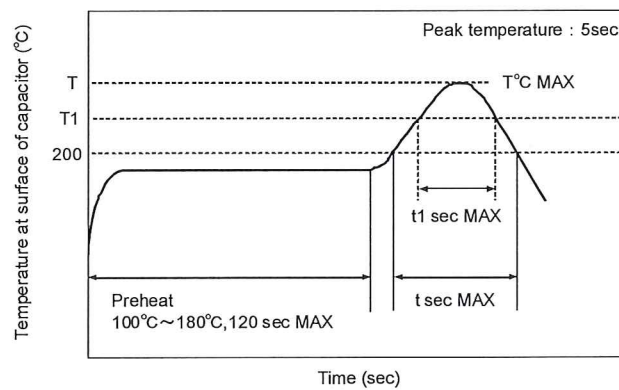

Peak Temp (T)	Peak Temp (T)	T1	The time of 200°C or more (t)	The time of 230°C or more (t1)	Reflow cycle
φ8	245°C	230°C	60 sec (max)	40 sec (max)	2
φ10	260°C	230°C	60 sec (max)	40 sec (max)	1

< Criteria >

Leakage Current	Not more than the values of Table-2
Capacitance Change	Within ±10% of the initial value
Dissipation Factor	Not more than the values of Table-2
ESR	Not more than the values of Table-2
Appearance	Notable changes shall not be found

13	Biased Humidity	<p>< Condition ></p> <p>Capacitors under test shall be applied the rated voltage continuously through 1000 ohm series protective resistor at $85\pm 2^{\circ}\text{C}$ and relative humidity of 85 to 90% for 2000^{+72}_0 hours. After the test and returned in standard atmospheric conditions for 1 to 2 hours, and the capacitor shall meet following requirements.</p> <p>< Criteria ></p> <table border="1" data-bbox="555 562 1433 752"> <tr> <td>Leakage Current</td> <td>Not more than the values of Table-2</td> </tr> <tr> <td>Capacitance Change</td> <td>Within $\pm 30\%$ of the initial value</td> </tr> <tr> <td>Dissipation Factor</td> <td>Not more than 200% of the values of Table-2</td> </tr> <tr> <td>ESR</td> <td>Not more than 200% of the values of Table-2</td> </tr> <tr> <td>Appearance</td> <td>Notable changes shall not be found</td> </tr> </table>	Leakage Current	Not more than the values of Table-2	Capacitance Change	Within $\pm 30\%$ of the initial value	Dissipation Factor	Not more than 200% of the values of Table-2	ESR	Not more than 200% of the values of Table-2	Appearance	Notable changes shall not be found
Leakage Current	Not more than the values of Table-2											
Capacitance Change	Within $\pm 30\%$ of the initial value											
Dissipation Factor	Not more than 200% of the values of Table-2											
ESR	Not more than 200% of the values of Table-2											
Appearance	Notable changes shall not be found											
14	Rapid change of Temperature	<p>< Condition ></p> <p>Capacitors shall be subjected the test for 10 cycles. Duration of exposure to each temperature limit of -55°C and $+135^{\circ}\text{C}$ shall be 30 minutes per cycle. After the test and returned in standard atmospheric conditions for 1 to 2 hours, and the capacitor shall meet following requirements. (If any doubt arises on the judgment, the capacitors shall be subjected to voltage treatment. See [8.Storage <Voltage treatment>])</p> <p>< Criteria ></p> <table border="1" data-bbox="571 1037 1433 1227"> <tr> <td>Leakage Current</td> <td>Not more than the values of Table-2</td> </tr> <tr> <td>Capacitance Change</td> <td>Within $\pm 10\%$ of the initial value</td> </tr> <tr> <td>Dissipation Factor</td> <td>Not more than the values of Table-2</td> </tr> <tr> <td>ESR</td> <td>Not more than the values of Table-2</td> </tr> <tr> <td>Appearance</td> <td>Notable changes shall not be found</td> </tr> </table>	Leakage Current	Not more than the values of Table-2	Capacitance Change	Within $\pm 10\%$ of the initial value	Dissipation Factor	Not more than the values of Table-2	ESR	Not more than the values of Table-2	Appearance	Notable changes shall not be found
Leakage Current	Not more than the values of Table-2											
Capacitance Change	Within $\pm 10\%$ of the initial value											
Dissipation Factor	Not more than the values of Table-2											
ESR	Not more than the values of Table-2											
Appearance	Notable changes shall not be found											

◆ Table-2 Electrical specifications

W.V. (V)	Nominal Capacitance (μ F)	Size ϕ DXL (mm)	$\tan \delta$ (120Hz, 20°C)	L.C. (μ A)	E.S.R. (m Ω ,max)		Rated Ripple Current (mA _{rms} /, 100kHz)	
					20°C, 100kHz	-40°C, 10kHz	125°C	135°C
					25	220	8X10.5	0.14
25	330	10X10.5	0.14	82.5	20	30	3600	2000
35	150	8X10.5	0.12	52.5	22	33	2900	1600
35	270	10X10.5	0.12	94.5	20	30	3600	2000

Frequency Coefficient for Ripple Current

Frequency	120Hz	1kHz	10kHz	100kHz \leq
Coefficient	0.05	0.30	0.70	1.00

11. Diagram of dimensions

< Chip TYPE >

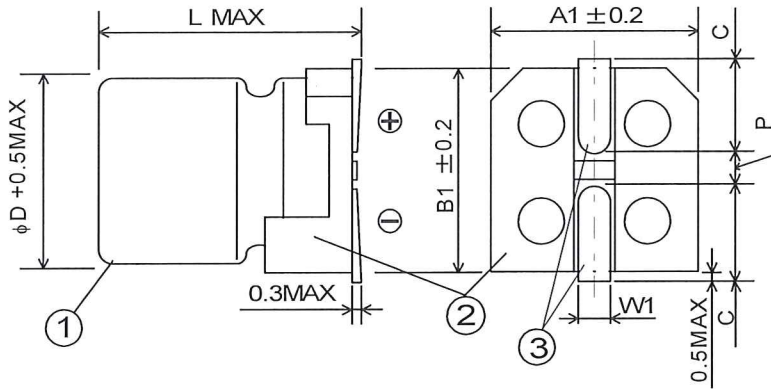

unit: mm

D	8	10
L	10.5	10.5
A1	8.3	10.3
B1	8.3	10.3
C	2.9	3.2
W1	0.8 to 1.1	0.8 to 1.1
P	3.1	4.5

①	Case	Aluminum (Laminated case)
②	Terminal base board	Heat resisting plastic
③	Lead Wire	CP Wire (Tin-Bismuth alloys plated)

12. Packing

12-1 Carrier Tape

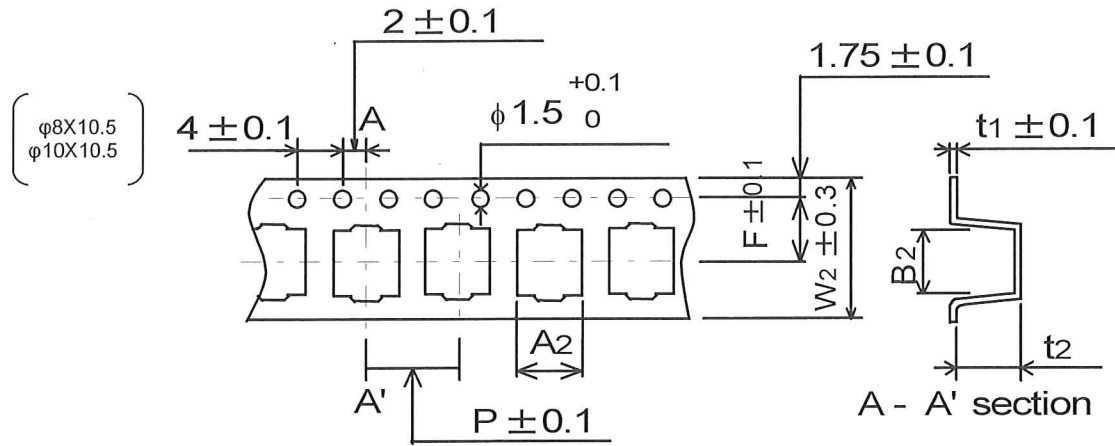

unit: mm

Size		W2	A2	B2	P	t2	F	t1
ϕD	L							
8	10.5	24.0	8.7	8.7	16.0	11.0	11.5	0.4
10	10.5	24.0	10.7	10.7	16.0	11.0	11.5	0.4

12-2 Reel size

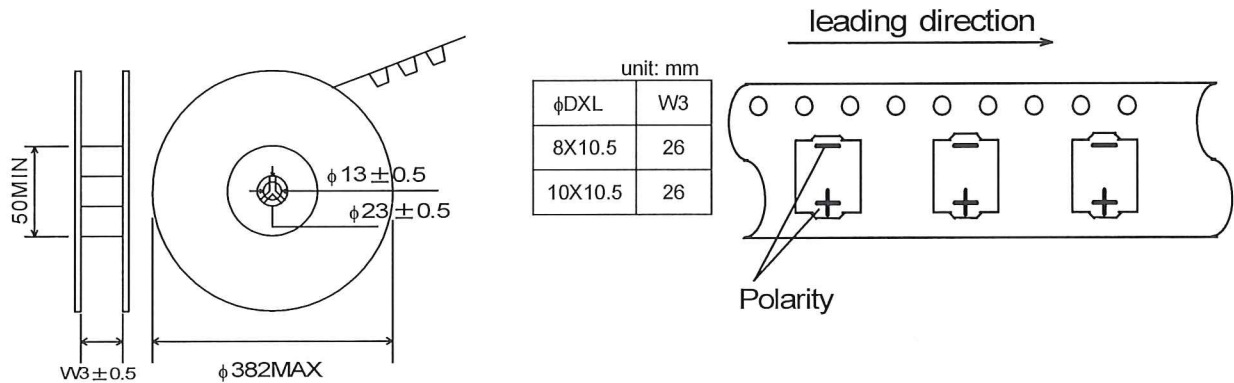

unit: mm

ϕDXL	W3
8X10.5	26
10X10.5	26

12-3 Quantity

Size	One reel
8X10.5	500 pcs
10X10.5	500 pcs

12-4 Packing form of the carrier tape

(a) Carrier tape after the last component.

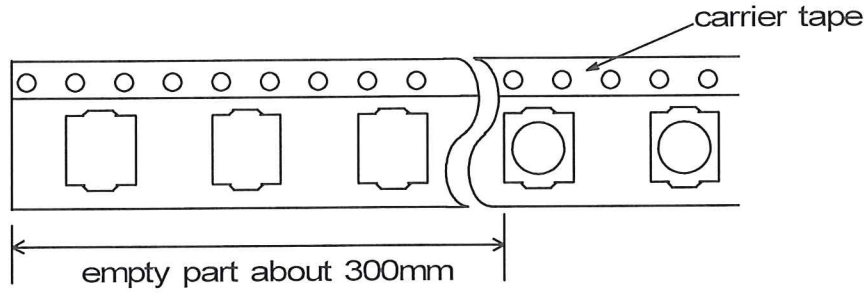

Carrier tape shall be inserted into reel without cover tape directly.

(b) Leader tape before the first component.

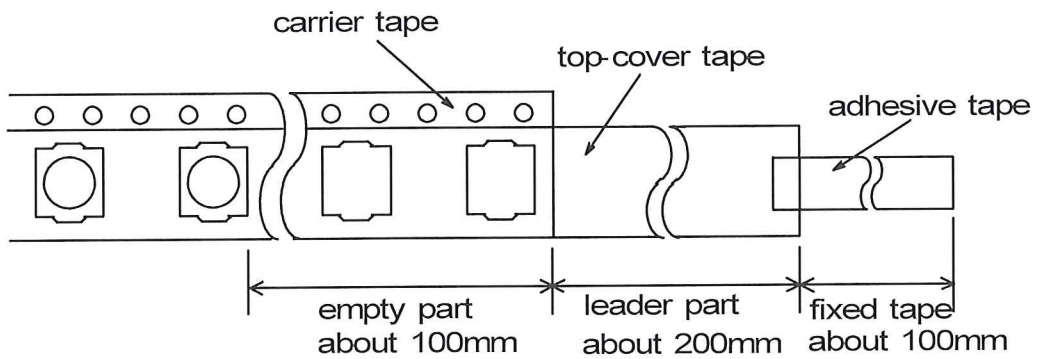

12-5 Deviation between carrier tape and top-cover tape

Deviation between carrier tape and top-cover tape shall not exceed 0.5mm.

Top-cover tape whose cover the feeding hole shall not exceed 0.75mm.

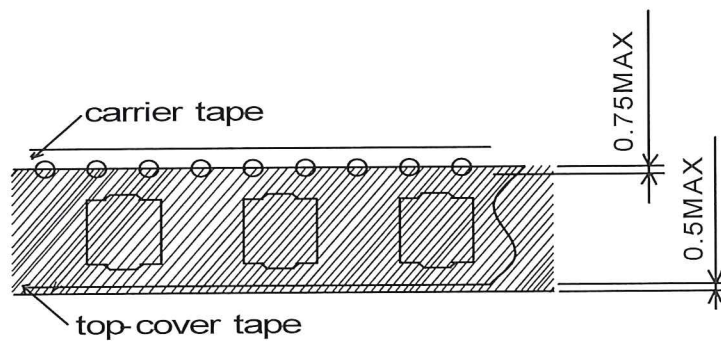

12-6 Connection of the carrier tape

- (a) Two pieces of embossed part of the each carrier tape shall be piled up without packing the capacitor in it and crashed by jigs. About connected part, carrier tape of the reel side shall be below one of leader side.

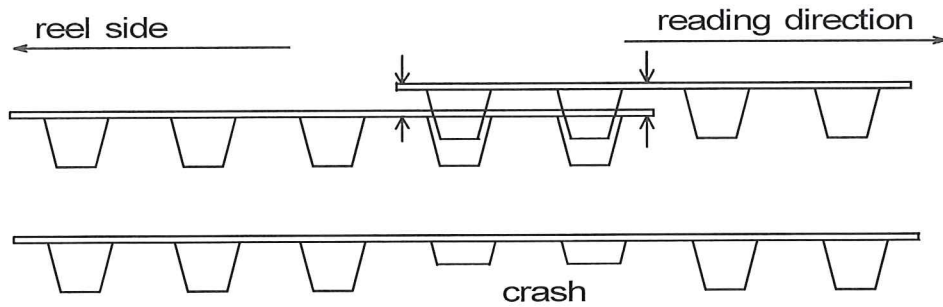

- (b) Number of connection per reel shall be within three places.

12-7 Adhesion test

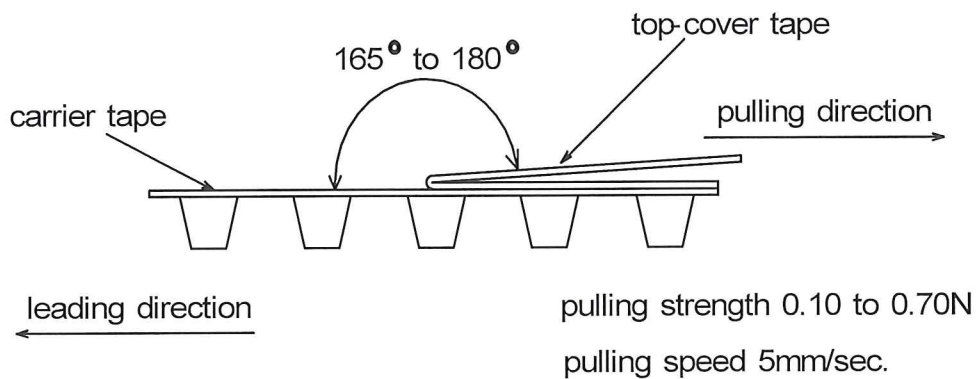

- 12-8 Carrier tape shall be reeled whose embossed part is inside.
(Top-cover tape shall be outside.)