



晶采光電科技股份有限公司  
AMPIRE CO., LTD.

## SPECIFICATIONS FOR LCD MODULE

<b>CUSTOMER</b>	
<b>CUSTOMER PART NO.</b>	
<b>AMPIRE PART NO.</b>	AM-1024768ZTZQW-00H
<b>APPROVED BY</b>	
<b>DATE</b>	

Approved For Specifications

Approved For Specifications & Sample

**AMPIRE CO., LTD.**

**Building A., 4F., No.116, Sec. 1, Sintai 5th Rd., Xizhi Dist,  
New Taipei City 221, Taiwan (R.O.C.)**

**新北市汐止區新台五路一段 116 號 4 樓(東方科學園區 A 棟)**

**TEL:886-2-26967269 , FAX:886-2-26967196 or 26967270**

APPROVED BY	CHECKED BY	ORGANIZED BY

## RECORD OF REVISION

Revision Date	Page	Contents	Editor
2016/06/28		New Release	Lawlite

## 1. Features

12.1 TFT Liquid Crystal Display module is a color active matrix thin film transistor (TFT) liquid crystal display (LCD) that uses amorphous silicon TFT as a switching device. It is composed of a TFT LCD panel, a driving circuit and a back light system. This TFT LCD has a 12.1 inch diagonally measured active display area with HD (1024 horizontal by 768 vertical pixel) resolution.

## 2. PHYSICAL SPECIFICATIONS

Item	Specifications	Remark
LCD size	12.1 inch(Diagonal)	
Driver element	a-Si TFT active matrix	
Display resolution	1024 (W) × 3(RGB) x768(H) dots	
Display mode	Normally Black	
Dot pitch	0.240 (W) x0.240 (H) mm	
Active area	245.76 (W) x 184.32 (H) mm	
Module size	260.5 (W) x 204 (H) × 8.4 (D) mm	
Color arrangement	RGB Vertical Stripe	
Surface treatment	Antiglare, Hard-Coating (3H)	
Weight	500	

### 3. ABSOLUTE MAXIMUM RATINGS

ITEM	SYMBOL	VALUES		UNIT	REMARK
		MIN	MAX		
Power Voltage	$V_{DD}$	-0.3	5.0	V	
	$V_{LED}$	-0.3	28	V	
Operation Temperature	$T_{op}$	-30	85	°C	
Storage Temperature	$T_{st}$	-40	90	°C	

Note 1: The absolute maximum rating values of this product are not allowed to be exceeded at any times.

Should a module be used with any of the absolute maximum ratings exceeded, the characteristics of the module may not be recovered, or in an extreme case, the module may be permanently destroyed.

## 4. ELECTRICAL SPECIFICATIONS

### 4.1 TFT LCD Module

Item	Symbol	Min.	Typ.	Max.	Unit	Note
Supply Voltage	$V_{DD}$	3.0	3.3	3.6	V	
Current of power supply	$I_{DD}$	—	TBD	—	A	$V_{DD} = 3.3V$ · Black pattern (L0)
VDD Power	$P_{DD}$	—	2.0	TBD	W	$V_{DD} = 3.3V$ · Black pattern (L0)
Inrush current	$I_{RUSH}$	—	—	2.0	A	Note*

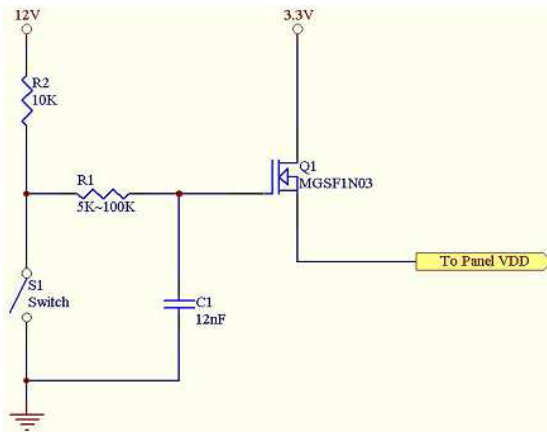

Test circuit

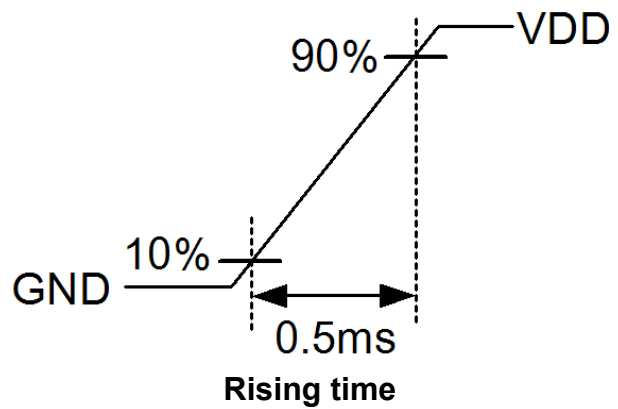

### 4.2 Switching Characteristics for LVDS Receiver

Item	Symbol	Min.	Typ.	Max.	Unit	Conditions
Differential Input High Threshold	$V_{TH}$			100	mV	
Differential Input Low Threshold	$V_{TL}$	-100			mV	
Differential input common mode voltage	$V_{CM}$	0.6	0.9	1.2	V	
Input Current	$I_{IN}$	-10		10	$\mu A$	$RX+/-$ , $RXC+/-$
Differential input Voltage	$V_{IH}/V_{IL}$	100		300	mV	

### 4.3 Bit LVDS input

#### 4.3.1 6bit LVDS input

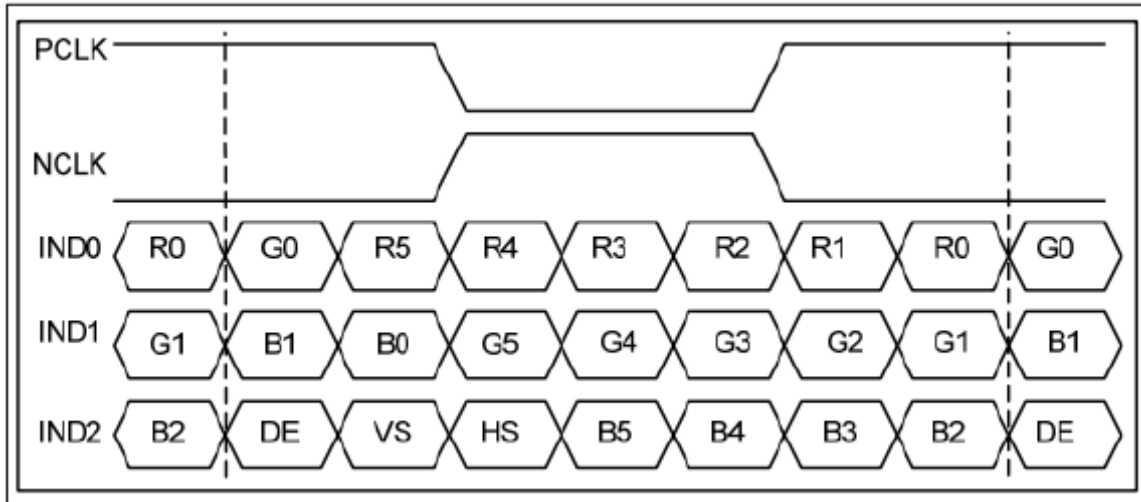

#### 4.3.2 8Bit LVDS input

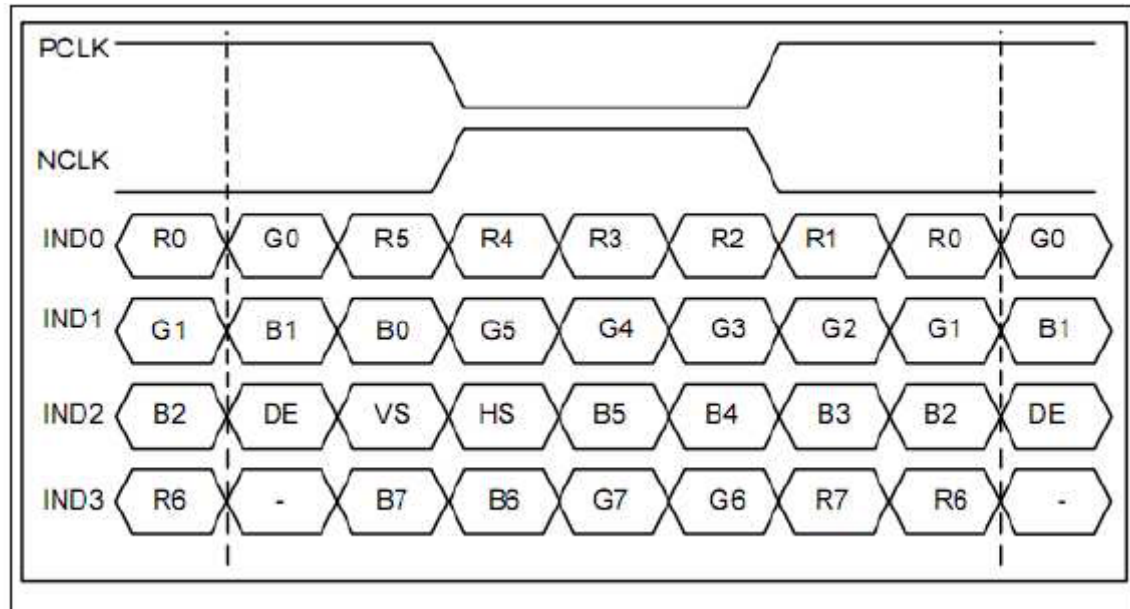

#### 4.4 Interface Timing (DE mode)

Item	Symbol	Min.	Typ.	Max.	Unit
Frame Rate	--	59.95	60.05	60.15	Hz
Vertical Total Time	$T_V$	774	776	778	line
Vertical Display Time	$T_{VD}$	768			line
Vertical Blanking Time	$T_{VB}$	6	8	10	line
Horizontal Total Time	$T_H$	1084	1088	1092	clock
Horizontal Display Time	$T_{HD}$	1024			clock
Horizontal Blanking Time	$T_{HB}$	60	64	68	clock
Clock Rate	$1/T_{Clock}$	50.3	50.7	51.1	MHz

#### Timing Diagram of Interface Signal (DE mode)

1. Vertical

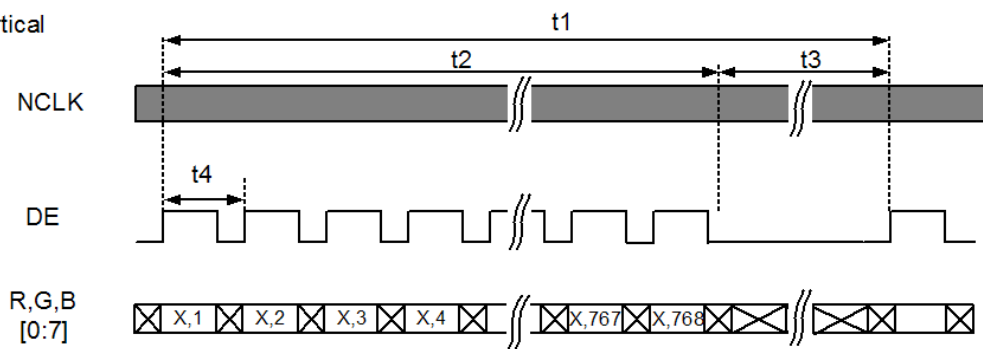

2. Horizontal

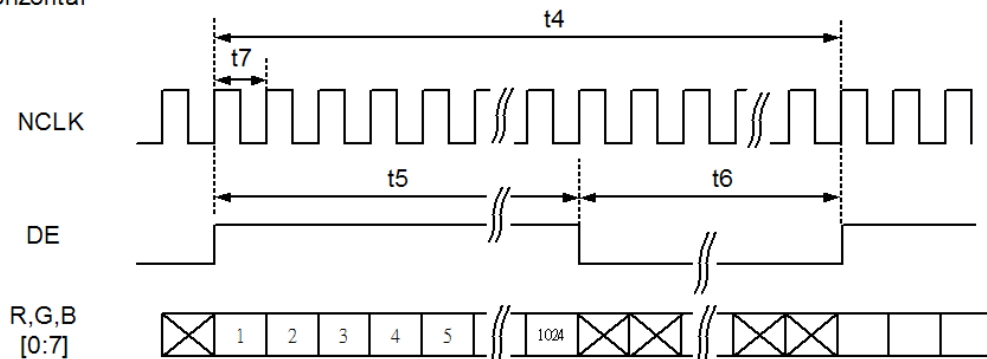

## 4.5 Power On / Off Sequence

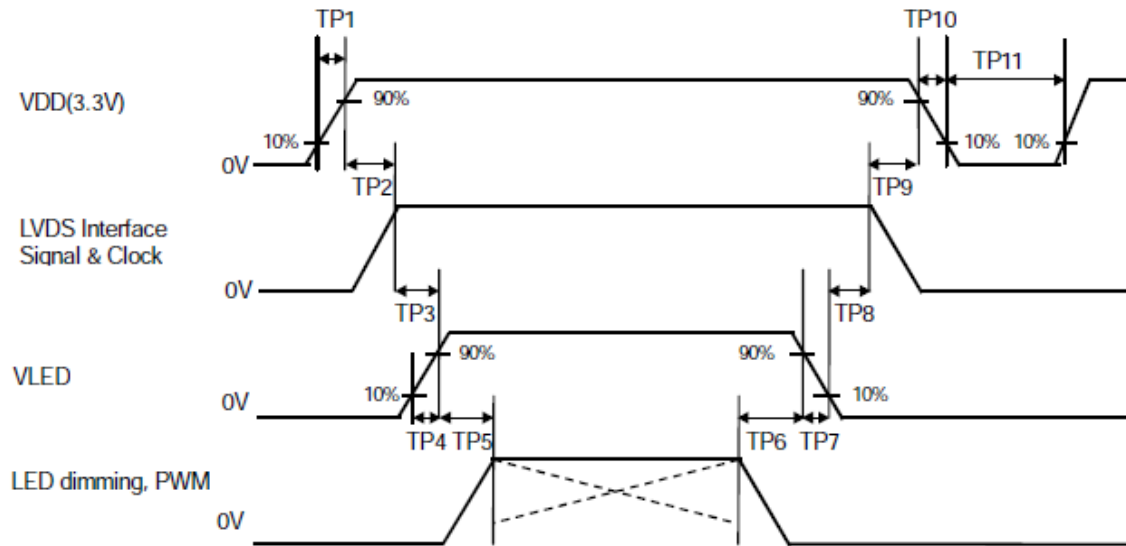

Item	Min.	Typ.	Max.	Unit
TP1	0.5	--	10	msec
TP2	0	--	50	msec
TP3	200	--	--	msec
TP4	0.5	--	10	msec
TP5	10	--	--	msec
TP6	10	--	--	msec
TP7	0	--	10	msec
TP8	200	--	--	msec
TP9	0	--	50	msec
TP10	1	--	10	msec
TP11	1000	--	--	msec



#### 4.6 Backlight Unit

Parameter	Symbol	Min	Typ	Max	Units	Condition
Input Current	$I_i$	--	950	TBD	mA	Ta=25°C
Input Voltage	$V_i$	10	12	16	Volt	Ta=25°C
LED Life-Time	N/A	30,000	--	--	Hour	Ta=25°C I <sub>F</sub> =60mA Note (2)

Note (1) LED life time (Hr) can be defined as the time in which it continues to operate under the condition: Ta=25±3 °C, typical IL value indicated in the above table until the brightness becomes less than 50%.

Note (2) The “LED life time” is defined as the module brightness decrease to 50% original brightness at Ta=25°C and I<sub>i</sub>=950mA, the LED lifetime could be decreased if operating IL is larger than 950mA. The constant current driving method is suggested.

Note (3) LED Light Bar Circuit

## 5. INTERFACE

### 5.1 Interface Connector (Input signal): STARCONN 076B20-0048RA-G4 or JAE FI-SEB20P-HFE (or equivalent)

Pin NO.	Symbol	Description	Note
1	RX3+	Differential Data Input, CH3 ( Positive )	
2	RX3-	Differential Data Input, CH3 (Negative )	
3	BIST	Normal operation/BIST pattern select. BIST="1" : Normal operation. BIST="0" : BIST mode	Note*
4	SEL68	6bit/8bit mode select, SELB = "1" : LVDS input data is 8bits SELB = "0" : LVDS input data is 6bits	Note*
5	GND	Ground	
6	RXC+	Differential Clock Input ( Positive )	
7	RXC-	Differential Clock Input ( Negative )	
8	GND	Ground	
9	RX2+	Differential Data Input , CH2 ( Positive )	
10	RX2-	Differential Data Input , CH2 ( Negative )	
11	GND	Ground	
12	RX1+	Differential Data Input , CH1 ( Positive )	
13	RX1-	Differential Data Input, CH1 ( Negative )	
14	GND	Ground	
15	RX0+	Differential Data Input, CH0 ( Positive )	
16	RX0-	Differential Data Input, CH0 (Negative )	
17	reLR	Left or right display control SHLR="1" : Left → Right SHLR="0" : Right → Left	Note*
18	reUD	Up / down display control UPDN="1" : Up → Down UPDN="0" : Down → Up	Note*
19	VDD	Power supply, 3.3V	
20	VDD	Power supply, 3.3V	

Note\* : The high level voltage "1" is 3.3V, and the low level voltage "0" is GND.

**Note 1 : UPDN and SHLR control function**

reLR	reUD	Data shifting
1	0	Right→Left, Up→Down
0	0	Left→Right, Up→Down
1	1	Right→Left, Down→Up
0	1	Left→Right, Down→Up

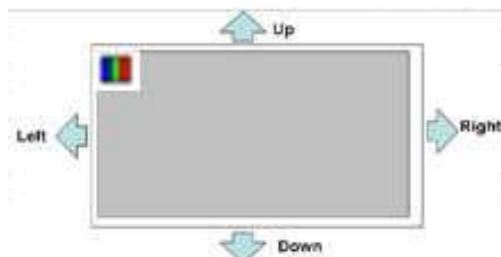

**5.2 Backlight Pin Assignment (CN2) : ACES 1208-01001-H01 (or equivalent)**

Pin NO.	Symbol	Description	Note
1	Vi	Converter input voltage	12V
2	Vi	Converter input voltage	12V
3	Vi	Converter input voltage	12V
4	Vi	Converter input voltage	12V
5	VGND	Converter ground	Ground
6	VGND	Converter ground	Ground
7	VGND	Converter ground	Ground
8	VGND	Converter ground	Ground
9	EN	Enable pin	3.3V
10	ADJ	Backlight Adjust	PWM Dimming (100Hz-30KHz, Hi: 2.0~3.3V, Lo : 0~0.8V)

## 6. Optical Specifications

Item	Symbol	Condition	Min.	Typ.	Max.	Unit	Note
Contrast	CR		600	900	—		(1)(2)
Response time	Rising	TR+TF	—	30	40	msec	(1)(3)
	Falling						
White luminance (Center)	$Y_L$		400	600	—	cd/m <sup>2</sup>	(1)(4) ( $I_L=240mA$ )
Color chromaticity (CIE1931)	White	$W_x$	$\Theta=0$ Normal viewing angle	0.273	0.313	0.353	(1)(4)
		$W_y$		0.289	0.329	0.369	
	Red	$R_x$			TBD		
		$R_y$			TBD		
	Green	$G_x$			TBD		
		$G_y$			TBD		
	Blue	$B_x$			TBD		
		$B_y$			TBD		
Viewing angle	Hor.	$\Theta_L$	CR>10	80	85	—	
		$\Theta_R$		80	85	—	
	Ver.	$\Theta_U$		80	85	—	
		$\Theta_D$		80	85	—	
Brightness uniformity	$B_{UNI}$	$\Theta=0$	70	80	—	%	(5)
Optima View Direction			Free				(6)

**Note (1)** Definition of Viewing Angle:

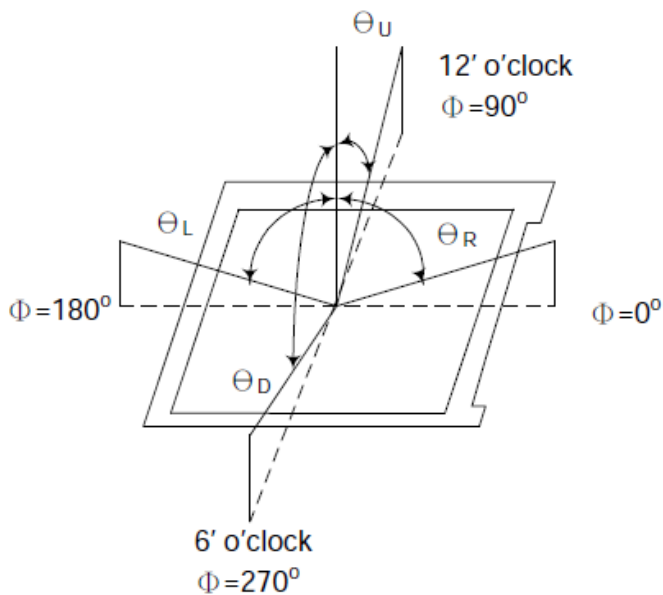

**Note (2)** Definition of Contrast Ratio (CR) :  
 measured at the center point of panel

$$CR = \frac{\text{Luminance with all pixels white}}{\text{Luminance with all pixels black}}$$

**Note (3)** Definition of Response Time : Sum of  $T_R$  and  $T_F$

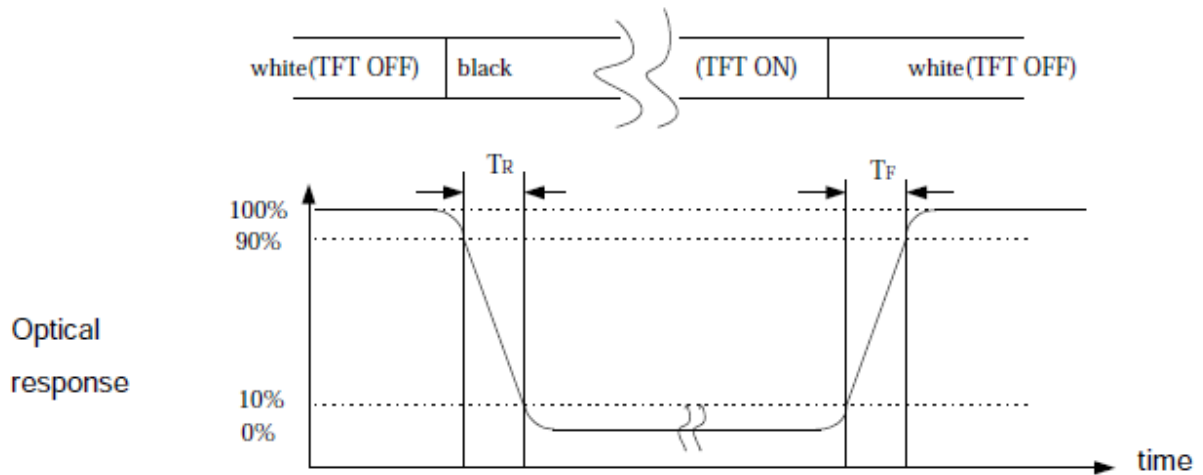

**Note (4)** Definition of optical measurement setup

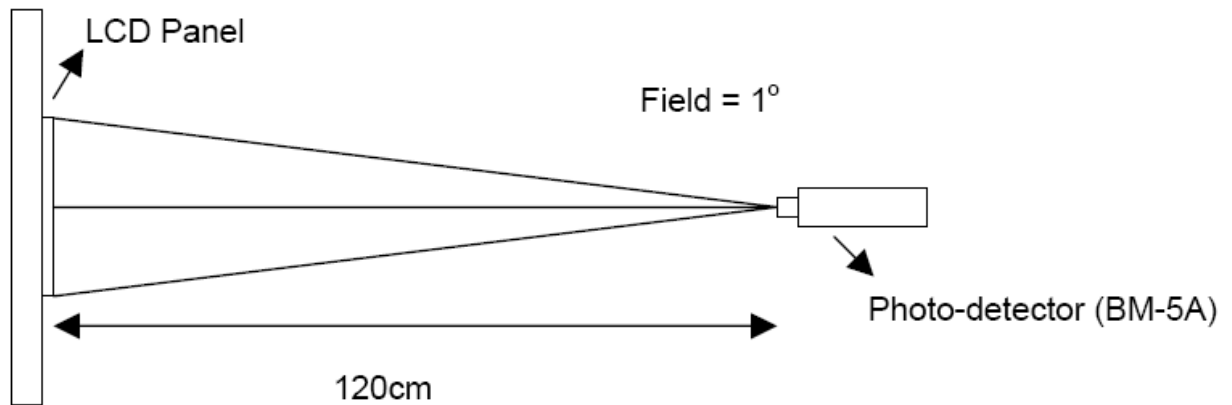

**Note (5)** Definition of brightness uniformity

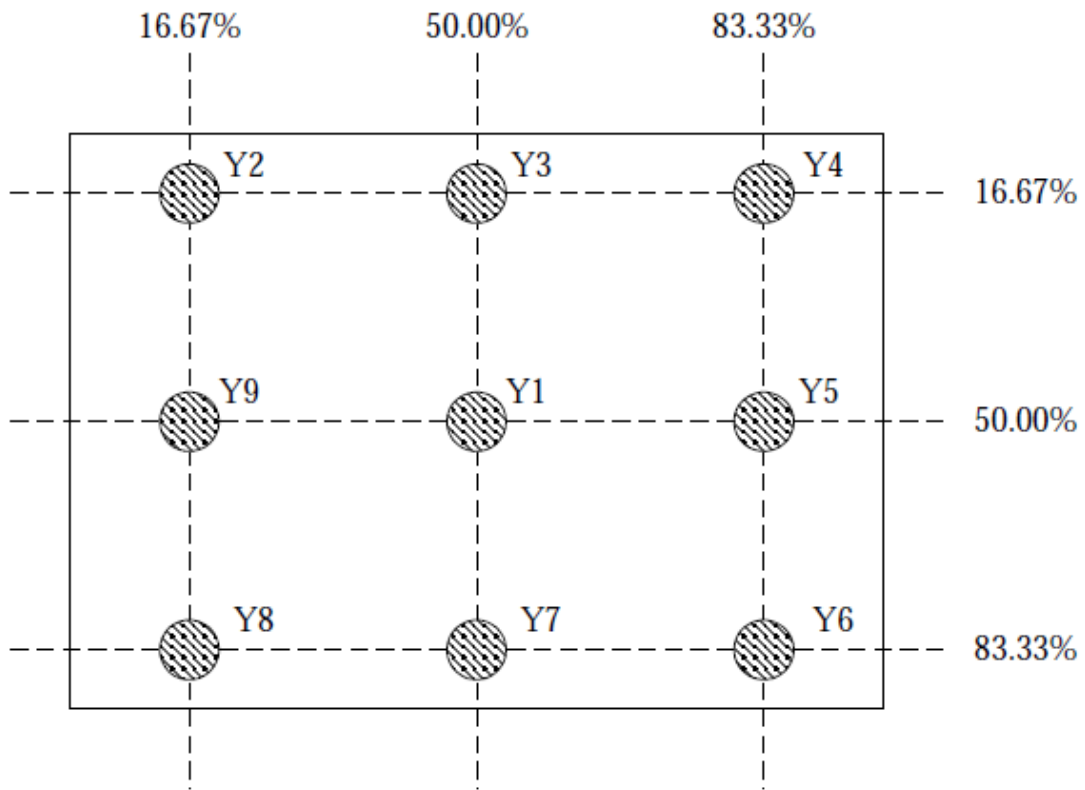

$$\text{Luminance uniformity} = \frac{(\text{Min Luminance of 9 points})}{(\text{Max Luminance of 9 points})} \times 100\%$$

Note (6) : Rubbing Direction (The different Rubbing Direction will cause the different optima view direction).

## 7. ELIABILITY TEST CONDITIONS

Test Item	Test Conditions	Note
High Temperature Operation	85±3°C ,Dry t=240 hrs	
Low Temperature Operation	-30±3°C, Dry t=240 hrs	
High Temperature Storage	90±3°C , Dry t=240 hrs	1,2
Low Temperature Storage	-40±3°C ,Dry t=240 hrs	1,2
Thermal Shock Test	-30°C ~ 25°C ~ 85°C 30 m in. 5 min. 30 min. ( 1 cycle ) Total 100 cycle(Dry)	1,2
Storage Humidity Test	60 °C, Humidity 90%, 240 hrs	1,2
Vibration Test (Packing)	Sweep frequency : 10 ~ 55 ~ 10 Hz/1min Amplitude : 0.75mm Test direction : X.Y.Z/3 axis Duration : 30min/each axis	2

Note 1 : Condensation of water is not permitted on the module.

Note 2 : The module should be inspected after 1 hour storage in normal conditions (15-35°C , 45-65%RH).

Definitions of life end point :

- Current drain should be smaller than the specific value.
- Function of the module should be maintained.
- Appearance and display quality should not have degraded noticeably.
- Contrast ratio should be greater than 50% of the initial value.

## **8. GENERAL PRECAUTION**

### **8.1 Use Restriction**

This product is not authorized for use in life supporting systems, aircraft navigation control systems, military systems and any other application where performance failure could be life-threatening or otherwise catastrophic.

### **8.2 Disassembling or Modification**

Do not disassemble or modify the module. It may damage sensitive parts inside LCD module, and may cause scratches or dust on the display. AMPIRE does not warrant the module, if customers disassemble or modify the module.

### **8.3 Breakage of LCD Panel**

- (1) If LCD panel is broken and liquid crystal spills out, do not ingest or inhale liquid crystal, and do not contact liquid crystal with skin.
- (2) If liquid crystal contacts mouth or eyes, rinse out with water immediately.
- (3) If liquid crystal contacts skin or cloths, wash it off immediately with alcohol and rinse thoroughly with water.
- (4) Handle carefully with chips of glass that may cause injury, when the glass is broken.

### **8.4 Electric Shock**

- (1) Disconnect power supply before handling LCD module.
- (2) Do not pull or fold the LED cable.
- (3) Do not touch the parts inside LCD modules and the fluorescent LED's connector or cables in order to prevent electric shock.

### **8.5 Absolute Maximum Ratings and Power Protection Circuit**

- (1) Do not exceed the absolute maximum rating values, such as the supply voltage variation, input voltage variation, variation in parts' parameters, environmental temperature, etc., otherwise LCD module may be damaged.
- (2) Please do not leave LCD module in the environment of high humidity and high temperature for a long time.
- (3) It's recommended to employ protection circuit for power supply.



## **8.6 Operation**

- (1) Do not touch, push or rub the polarizer with anything harder than HB pencil lead.
- (2) Use fingerstalls of soft gloves in order to keep clean display quality, when persons handle the LCD module for incoming inspection or assembly.
- (3) When the surface is dusty, please wipe gently with absorbent cotton or other soft material.
- (4) Wipe off saliva or water drops as soon as possible. If saliva or water drops contact with polarizer for a long time, they may cause deformation or color fading.
- (5) When cleaning the adhesives, please use absorbent cotton wetted with a little petroleum benzene or other adequate solvent.

## **8.7 Mechanism**

Please mount LCD module by using mounting holes arranged in four corners tightly.

## **8.8 Static Electricity**

- (1) Protection film must remove very slowly from the surface of LCD module to prevent from electrostatic occurrence.
- (2) Because LCD modules use CMOS-IC on circuit board and TFT-LCD panel, it is very weak to electrostatic discharge. Please be careful with electrostatic discharge. Persons who handle the module should be grounded through adequate methods.

## **8.9 Strong Light Exposure**

The module shall not be exposed under strong light such as direct sunlight. Otherwise, display characteristics may be changed.

## **8.10 Disposal**

When disposing LCD module, obey the local environmental regulations.

## **8.11 Others**

Do not keep the LCD at the same display pattern continually. The residual image will happen and it will damage the LCD. Please use screen saver.

# 9. OUTLINE DIMENSION

