



晶采光電科技股份有限公司
AMPIRE CO., LTD.

SPECIFICATIONS FOR LCD MODULE

CUSTOMER	
CUSTOMER PART NO.	
AMPIRE PART NO.	AM-1280800NGTZQW-T45H
APPROVED BY	
DATE	

Approved For Specifications

Approved For Specifications & Sample

AMPIRE CO., LTD.

**Building A., 4F., No.116, Sec. 1, Sintai 5th Rd., Xizhi Dist,
New Taipei City 221, Taiwan (R.O.C.)**

新北市汐止區新台五路一段 116 號 4 樓(東方科學園區 A 棟)

TEL:886-2-26967269 , FAX:886-2-26967196 or 26967270

APPROVED BY	CHECKED BY	ORGANIZED BY

RECORD OF REVISION

Revision Date	Page	Contents	Editor
2016/05/24		New Release	Alan

1. Features

10.1 TFT Liquid Crystal Display module is a color active matrix thin film transistor (TFT) liquid crystal display (LCD) that uses amorphous silicon TFT as a switching device. It is composed of a TFT LCD panel, a timing controller, voltage reference, common voltage, column driver, and row driver circuit. This TFT LCD has a 10.1-inch diagonally measured active display area with 1280 horizontal by 800 vertical pixel array resolution.

- Projected Capacitive Touch Screen
 - I2C Interface
 - TP Controller (EETI EX3132)
- Cover lens

2. PHYSICAL SPECIFICATIONS

Item	Specifications	Remark
LCD size	10.1 inch(Diagonal)	
Driver element	a-Si TFT active matrix	
Display resolution	1280 (W) × 3(RGB) x 800(H) dots	
Display mode	Normally Black, Transmissive (IPS)	
Dot pitch	0.1695 (W) x0.1695 (H) mm	
Active area	216.96 (W) x 135.6 (H) mm	
Module size	247.0 (W) x 166.0 (H) × 9.25 (D) mm	
Color arrangement	R.G.B-stripe	
Interface	Digital	
Weight	TBD	

3. ABSOLUTE MAXIMUM RATINGS

ITEM	SYMBOL	VALUES		UNIT	REMARK
		MIN	MAX		
Power Voltage	V_{DD}	-0.3	7.0	V	VSS=0V, TA=25°C
	V_{LED}	-0.3	24	V	
Operation Temperature	T_{op}	-20	70	°C	
Storage Temperature	T_{st}	-30	80	°C	

Note 1: The absolute maximum rating values of this product are not allowed to be exceeded at any times.

Should a module be used with any of the absolute maximum ratings exceeded, the characteristics of the module may not be recovered, or in an extreme case, the module may be permanently destroyed.

4. ELECTRICAL SPECIFICATIONS

4.1 Typical Operation Conditions

Item	Symbol	Min	Typ	Max	Unit	Note
LCD Drive Voltage	VDD	3.0	3.3	3.6	V	(2),(4)
VDD Current	White Pattern IDD	--	0.27	--	A	(3),(4)
VDD Power Consumption	White Pattern PDD	--	--	1.0	W	(3),(4)
Rush Current	Irush			1.5	A	(1),(4),(5)
Allowable Logic/LCD Drive Ripple Voltage	VDDrp			300	mV	(4)

Note 1.Measure Condition

Figure 9 VDD rising time

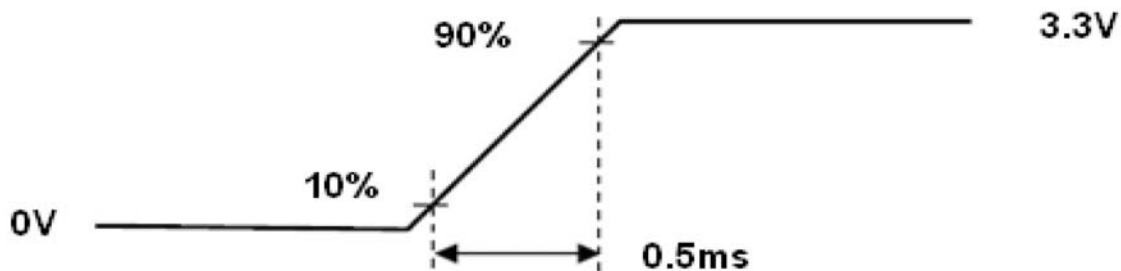

VDD rising time

Note 2.VDD Power Dip Condition

If $V_{TH} < V_{DDRVmin}$, then $td < 10ms$; when the voltage return to normal our panel must revive automatically.

Figure 12 VDD Power Dip

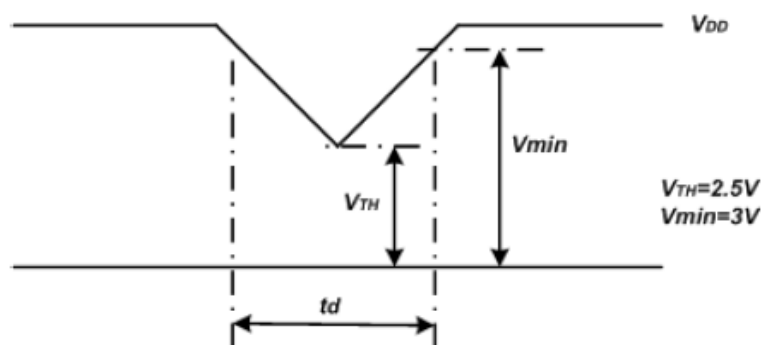

- Note (3) Frame Rate=60Hz, VDD=3.3V,DC Current.
- Note (4) Operating temperature 25°C , humidity 55%RH.
- Note (5) The reference measurement circuit of rush current.

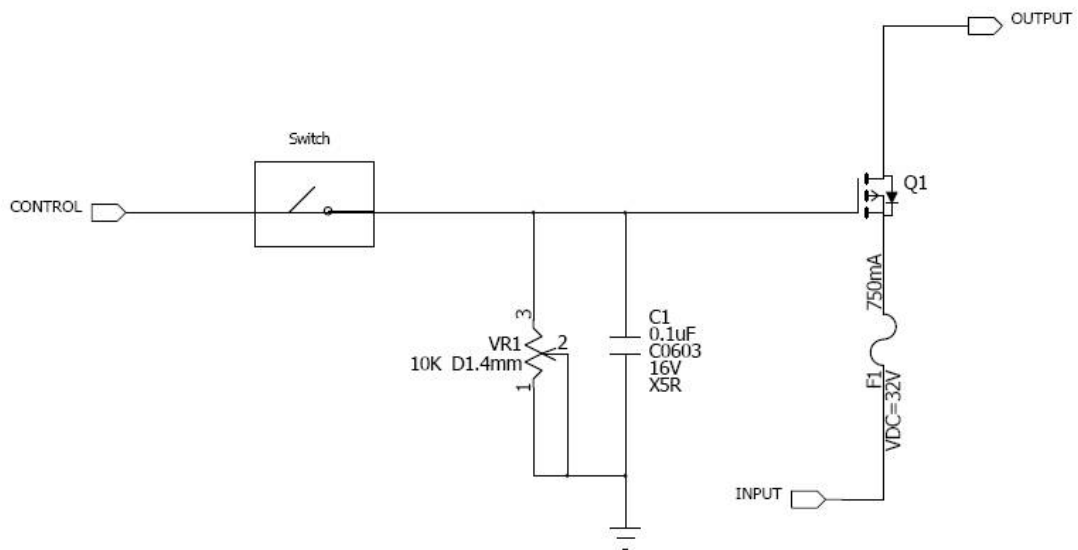

4-2 LED Driving Conditions

ITEM	SYMBOL	MIN	TYP	MAX	UNIT	CONDITION
LED Backlight Voltage	V_{BL}	--	22	24	V	For reference
LED Backlight Current	I_{BL}	-	360	--	mA	Ta=25°C
LED Life Time		--	50K	-	KHr	Note*

Note* : Brightness to be decreased to 50% of the initial value.

Ta=25°C

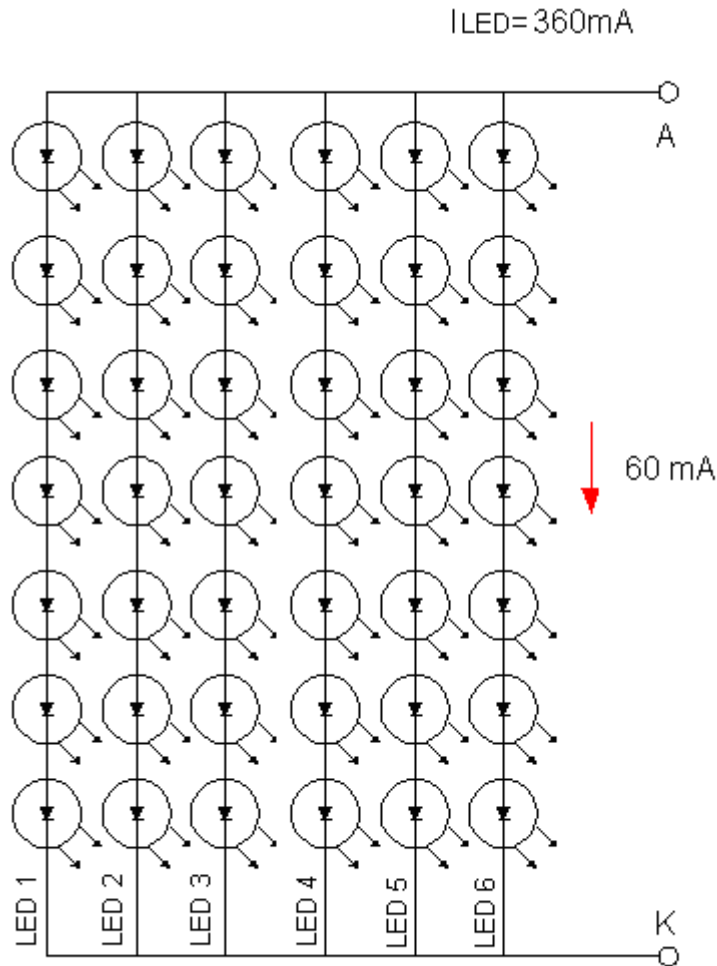

When LCM is operated over 40°C ambient temperature, the I_{LED} should be follow :

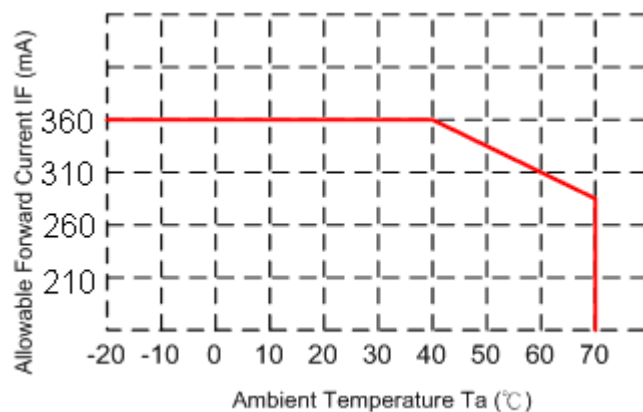

4.3 Power Sequence

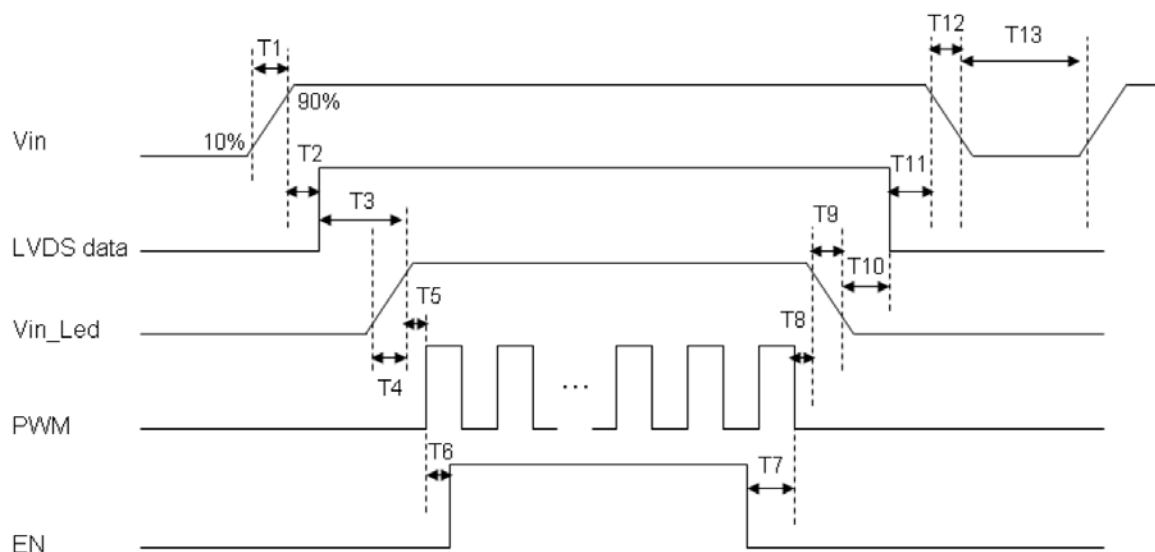

Table 10 Power Sequencing Requirements

Parameter	Symbol	Unit	Min	Typ.	Max
VIN Rise Time	T1	ms	0.5	--	10
VIN Good to Signal Valid	T2	ms	30	--	90
Signal Valid to Backlight On	T3	ms	200	--	--
Backlight Power On Time	T4	ms	0.5	--	--
Backlight VDD Good to System PWM On	T5	ms	10	--	--
System PWM ON to Backlight Enable ON	T6	ms	10	--	--
Backlight Enable Off to System PWM Off	T7	ms	0	--	--
System PWM Off to B/L Power Disable	T8	ms	10	--	--
Backlight Power Off Time	T9	ms	--	10	30
Backlight Off to Signal Disable	T10	ms	200	--	--
Signal Disable to Power Down	T11	ms	0	--	50
VIN Fall Time	T12	ms	--	10	30
Power Off	T13	ms	500	--	--

4.4 LVDS Signal Timing Characteristics

4.4.1 AC Electrical Characteristics

Parameter	Symbol	Min.	Typ.	Max.	Unit	Conditions
Differential Input High	V _{th}	-	-	+100	mV	V _{CM} =+1.2V
Differential Input Low	V _{tl}	-100	-	-	mV	V _{CM} =+1.2V
Magnitude Differential Input	V _{ID}	200	-	400	mV	-
Common Mode Voltage	V _{CM}	0.3+ (V _{ID} /2)	-	VDD-1.2- (V _{ID} /2)	V	-
Common Mode Voltage	ΔV _{CM}	-	-	50	mV	V _{CM} =+1.2V

Note (1) Input signals shall be low or Hi-Z state when VDD is off.

(2) All electrical characteristics for LVDS signal are defined and shall be measured at the interface connector of LCD.

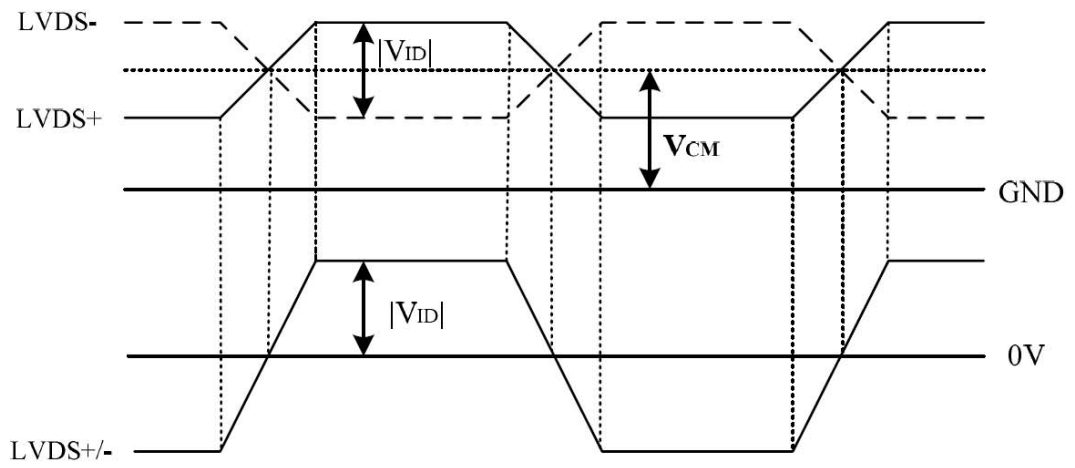
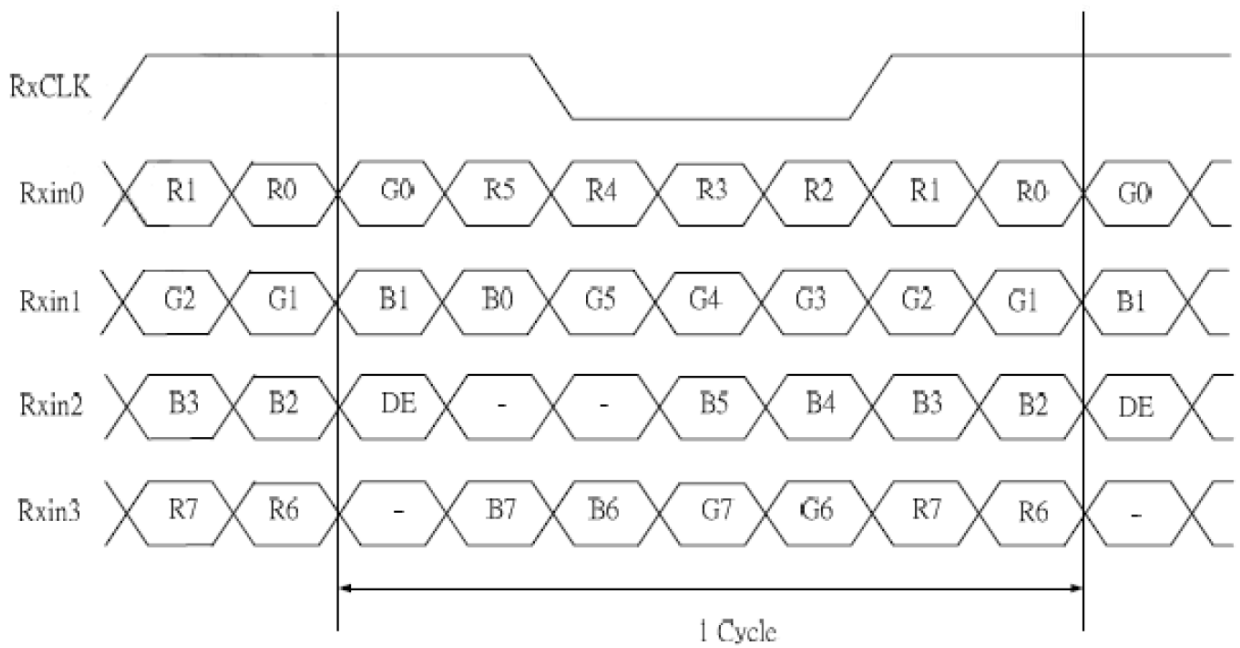
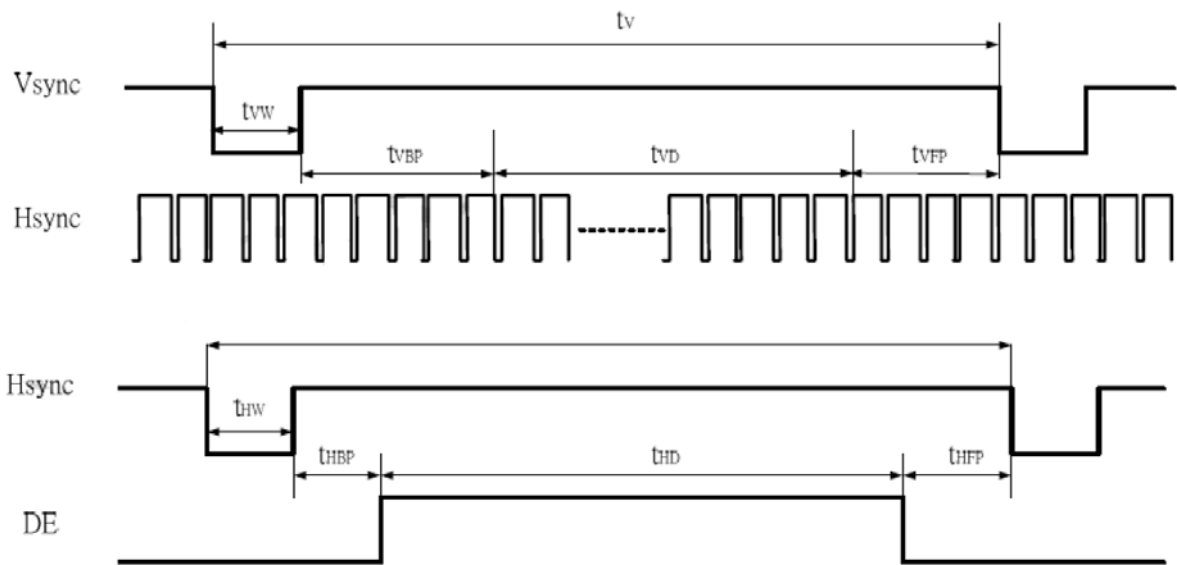

Figure 9 LVDS Data Mapping



4.4.2 Timing Table

Parameter	Symbol	Unit	Min.	Typ.	Max.
Frame Rate	--	Hz	-	60	-
Frame Period	t_v	line	(815)	(823)	(1023)
Vertical Display Time	t_{VD}	line	800		
Vertical Blanking Time	$t_{VW}+t_{VBP}+t_{VFP}$	line	(15)	(23)	(33)
1 Line Scanning Time	t_H	clock	(1410)	(1440)	(1470)
Horizontal Display Time	t_{HD}	clock	1280		
Horizontal Blanking Time	$t_{HW}+t_{HBP}+t_{HFP}$	clock	(60)	(160)	(190)
Clock Rate	$1/T_C$	MHz	(68.9)	(71.1)	(73.4)



5. INTERFACE

Interface Connector (Input signal): Starconn / 300E40-0010RA-G3

Pin #	Signal Name	Description	Remarks
1	NC	Not Connect	-
2	VDD	Power Supply, 3.3V (typical)	-
3	VDD	Power Supply, 3.3V (typical)	
4	VDD_EDID	Power Supply for EDID I2C Flash IC	
5	SCL_EDID	I2C Serial Clock for EDID I2C Flash IC	
6	SDA_EDID	I2C Serial Data for EDID I2C Flash IC	
7	NC	Not Connect	
8	LV0N	-LVDS differential data input	
9	LV0P	+LVDS differential data input	
10	GND	Ground	
11	LV1N	-LVDS differential data input	
12	LV1P	+LVDS differential data input	
13	GND	Ground	
14	LV2N	-LVDS differential data input	
15	LV2P	+LVDS differential data input	
16	GND	Ground	
17	LVCLKN	-LVDS differential data input	
18	LVCLKP	+LVDS differential data input	
19	GND	Ground	
20	LV3N	-LVDS differential data input	
21	LV3P	+LVDS differential data input	
22	GND	Ground	
23	NC	Not Connect	
24	NC	Not Connect	
25	NC	Not Connect	
26	NC	Not Connect	
27	NC	Not Connect	
28	NC	Not Connect	
29	CABC_EN	Content Adaptive Brightness Control Function Enable	Enable: Hi Disable:Lo
30	NC	Not Connect	
31	NC	Not Connect	
32	NC	Not Connect	
33	NC	Not Connect	
34	NC	Not Connect	
35	BIST	BIST pin	
36-40	NC	Not Connect	

6. Optical Specifications

Table 2 Optical Characteristics

Item	Conditions		Min.	Typ.	Max.	Unit	Note	
Viewing Angle (CR>10)	Horizontal	θ_L	(75)	(85)	-	degree	(1),(2),(3)	
		θ_R	(75)	(85)	-			
	Vertical	θ_T	(75)	(85)	-			
		θ_B	(75)	(85)	-			
Contrast Ratio	Center		(600)	(800)	-	-	(1),(2),(4)	
Response Time	Rising		-	-	-	ms	(1),(2),(5)	
	Falling		-	-	-	ms		
	Rising + Falling		-	25	-	ms		
Color Chromaticity (CIE1931)	NTSC		-	45	-	%	(1),(2)	
	Red	x	Typ. -0.05	0.561	Typ. +0.05	-	(1),(2)	
	Red	y		0.334		-		
	Green	x		0.341		-		
	Green	y		0.568		-		
	Blue	x		0.161		-		
	Blue	y		0.129		-		
	White	x		-		0.313		-
White	y	-		0.329		-		-
White Luminance	Center		1000	1270	-	cd/m ²	(1),(2),(6)	
Luminance Uniformity	9Points		70	75	-	%	(1),(2),(6)	

Note (1) Measurement Setup:

The LCD module should be stabilized at given temperature(25°C) for 15 minutes to Avoid abrupt temperature change during measuring. In order to stabilize the luminance, the measurement should be executed after lighting backlight for 15 minutes in a windless room.

Figure 4 Measurement Setup

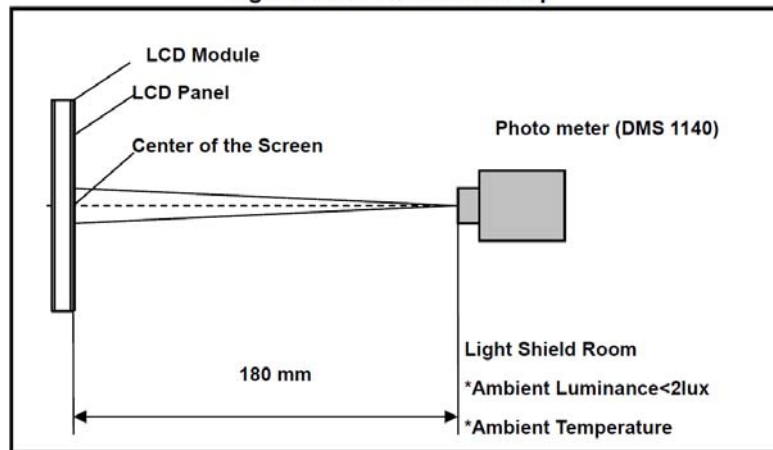
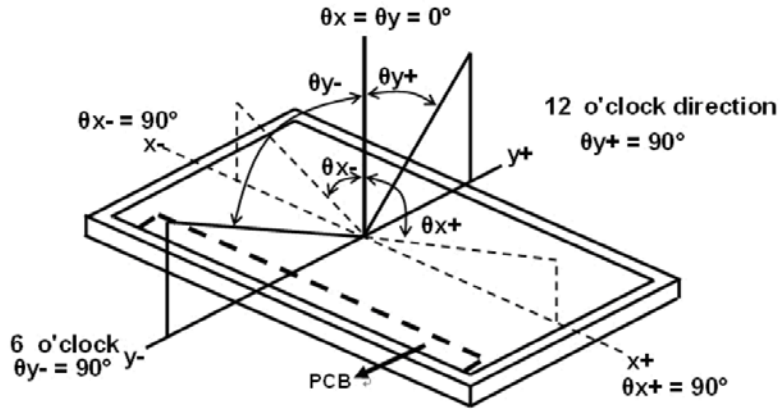

Figure 5 Definition of Viewing Angle



Note (4) Definition Of Contrast Ratio (CR)

The contrast ratio can be calculated by the following expression

$$\text{Contrast Ratio (CR)} = L_{255} / L_0$$

L63: Luminance of gray level 255, L0: Luminance of gray level 0

Note (5) Definition Of Response Time (T_R , T_F)

Figure 6 Definition of Response Time

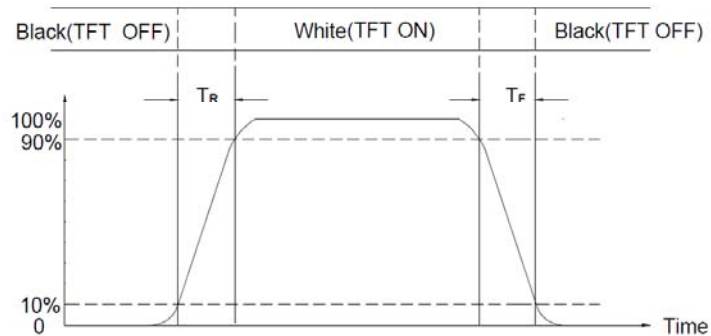

Note (6) Definition Of brightness Luminance

$$\text{Luminance uniformity} = \frac{\text{Min}(L_1, L_6, L_7, L_8, L_9, L_{10}, L_{11}, L_{12}, L_{13})}{\text{Max}(L_1, L_6, L_7, L_8, L_9, L_{10}, L_{11}, L_{12}, L_{13})} \times 100\%$$

H—Active area length V—Active area width

Figure 7 Measurement Locations

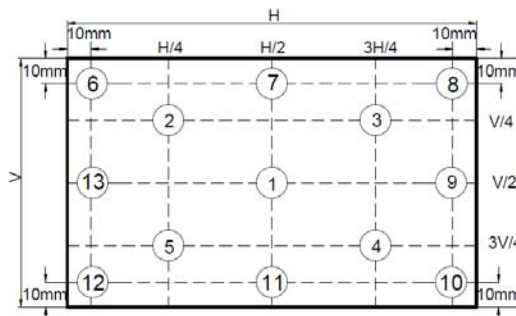

7. Projected capacitive-type Touch panel specification

7.1 Basic Characteristic

ITEM	SPECIFICATION
Type	Projective Capacitive Touch Panel
Activation	Two-fingers or Single-finger
X/Y Position Reporting	Absolute Position
Touch Force	No contact pressure required
Calibration	No need for calibration
Report Rate	Approx 100 points/sec
Control IC	EETI EX3132

Item	Symbol	Min.	Typ.	Max.	Unit
Power Supply Voltage	VDD	3	3.3	3.6	V
Low Level Input Voltage	VIL	0	--	0.8	V
High Level Input Voltage	VIH	0.8*VIN	--	VIN	V

7.2 Interface

I2C		
Pin No.	Symbol	Function
1	VDD	Power Supply for TP controller
2	SCL	I2C Clock
3	SDA	I2C Data
4	/INT	Interrupt Output pin. Active "Low"
5	RES	Rest input pin to Master Chip. Active "Low"
6	GND	Power GND

7.3 Power- on Timing Chart

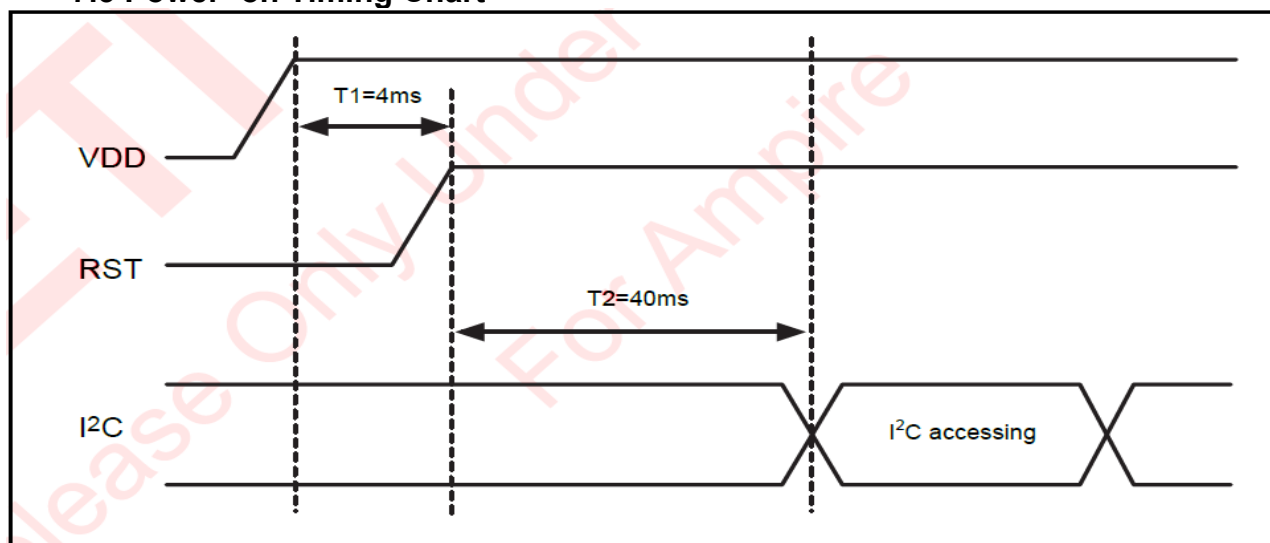

7.4 I2C AC Waveform

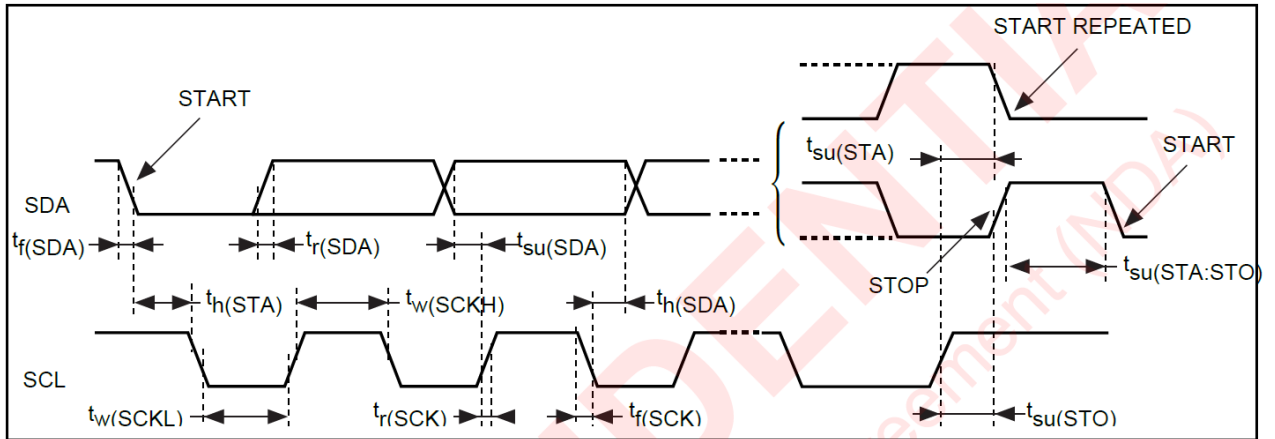

7.5 I2C Characteristics

Symbol	Parameter	SCL = 100KHz		SCL = 400KHz		Unit
		Min	Max	Min	Max	
$t_w(SCLH)$	SCL clock high time	4.7		1.3		μs
$t_w(SCLL)$	SCL clock low time	4.0		0.6		
$t_{su}(SDA)$	SDA setup time	250		100		ns
$t_h(SDA)$	SDA data hold time	0		0	900	
$t_r(SDA)$ $t_r(SCL)$	SDA and SCL rise time		1000		300	
$t_f(SDA)$ $t_f(SCL)$	SDA and SCL fall time		300		300	μs
$t_h(STA)$	Start condition hold time	4.0		0.6		
$t_{su}(STA)$	Repeated Start condition setup time	4.7		0.6		
$t_{su}(STO)$	Stop condition setup time	4.0		0.6		μs
$t_w(STO:STA)$	Stop to Start condition time (bus free)	4.7		1.3		μs

7.6 Software Protocol

I2C Transaction Frame: each I2C transaction frame transfers one I2C packet data. The IRQ pin is low level trigger.

The controller will pull IRQ pin low until no data in the controller buffer.

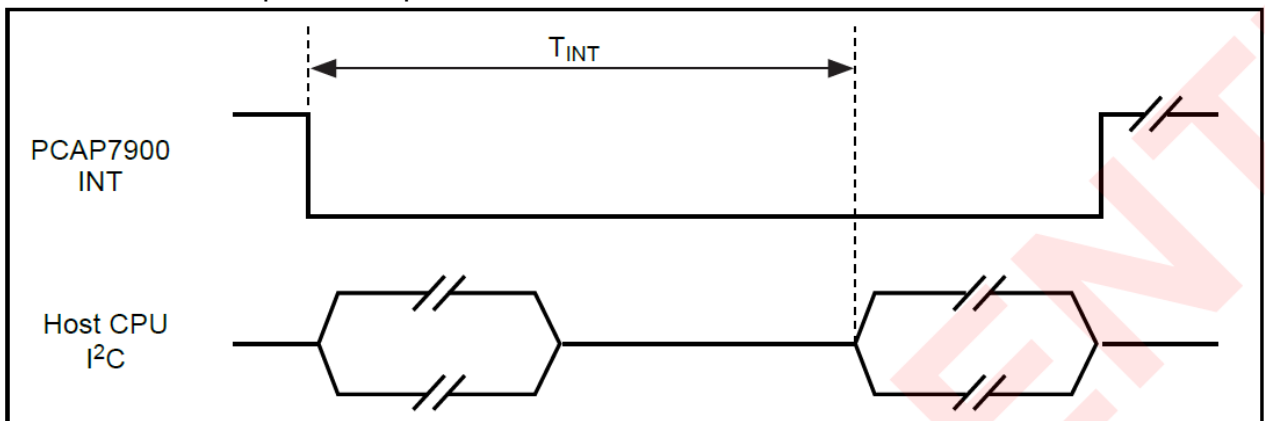

Report rate = $1 / T_{INT}$, it depends on properties of touch screen such as resistive value,

I2C clock rate, channel number, thickness and material of cover lens, etc.
 For better touch performance, we strongly recommend using the 400K clock rate.

	From Host to Device
	From Device to Host

- S = START condition
- Sr = Repeat START condition
- P = STOP condition
- R = Data direction READ (SDA HIGH)
- W = Data direction WRITE (SDA LOW)
- Ack = Acknowledge (SDA LOW)
- Nak = Not acknowledge (SDA HIGH)
- Address = 7-bit (0x2A)
- DATA = 8-bit

Read mode: Host-receiver, Device-transmitter.

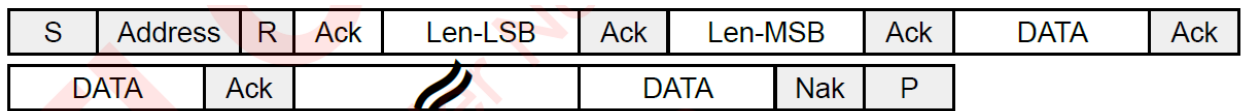

Host need to read 66 Bytes for input report retrieval. The total 66 Bytes contains 2 Bytes "Length" and 64 Bytes data payload. The value of "Len" is calculated by 2 Bytes for "Len" field and n Bytes for valid "Input Data" in the payload.

The input data packet format inside the I2C payload is defined as



According to different report ID, there are different data format as below.
 Report ID = 6, for parallel mode multi-touch data.

Multi-Touch format:

Byte0	Byte1								
Report ID = 0x06	Num Of Fingers*								
Byte2	Byte3	Byte4	Byte5	Byte6	Byte7	Byte8	Byte9	Byte10	Byte11
Contact data 1									
Byte12	Byte13	Byte14	Byte15	Byte16	Byte17	Byte18	Byte19	Byte20	Byte21
Contact data 2									
Byte22	Byte23	Byte24	Byte25	Byte26	Byte27	Byte28	Byte29	Byte30	Byte31
Contact data 3									
Byte32	Byte33	Byte34	Byte35	Byte36	Byte37	Byte38	Byte39	Byte40	Byte41
Contact data 4									
Byte42	Byte43	Byte44	Byte45	Byte46	Byte47	Byte48	Byte49	Byte50	Byte51
Contact data 5									
Byte52	Byte53	Byte54	Byte55						
Scan Time									

The device input report contains maximum 5 contacts in one I2C frame. If it must report 10 contacts, device will break these down into 2 I2C frames that report 5 contacts each. The “Nums of Fingers” indicates the actual contact in this report. The actual contact number is reported in the first frame. The other frames should have an actual count of 0. For 10 contacts example, the actual count in the first frame has a value of 10, and the second frame has an actual count of 0.

Contact data format:

Byte0	Byte1	Byte2	Byte3	Byte4	Byte5	Byte6	Byte7	Byte8	Byte9
State**	Finger ID	X *** (LSB)	X (MSB)	Y *** (LSB)	Y (MSB)	reserved		reserved	

** tate: Bit0=Down/Up bit, Bit0 = 1 for Touch Down, Bit0 = 0 for Lift off.

*** The X/Y resolution is 4096.

Report ID = 3, for vendor specific diagnostics data.

Diagnostics packet format

Byte0	Byte1	
Report ID = 0x03	Length	

The “Length” indicates the length of the coming data stream. This data stream must follow EETI eGalax diagnostics format. The software integrator must be carefully handling this data stream.

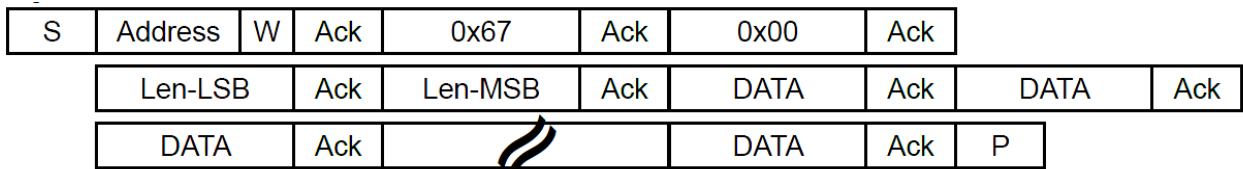

Write mode: Host-transmitter, Device-receiver.

Host need to write 2 Bytes [0x67] [0x00] to device first, and follow 2 Bytes length field and data payload. Each I2C transaction always contains 64 Bytes data payload so the length field should be always as 66 Bytes (2 Bytes for “Len”+64 Bytes for “Data” payload).If the data to be sent to the controller is less than 64 Bytes, 0 padding is necessary.

The packet format in the payload is defined as diagnostics packet.

Diagnostics packet format:

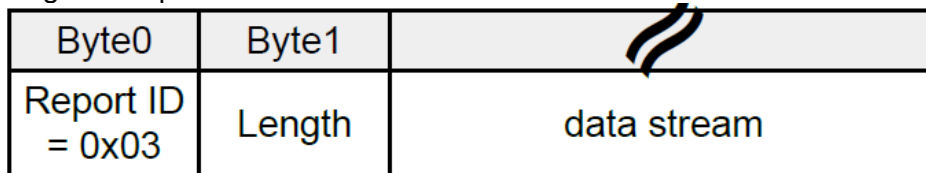

The “Length” indicates the length of the coming data stream. This data stream must follow EETI eGalax diagnostics format. The software integrator must be carefully handling this data stream.

7.7 Command Example

Query firmware version

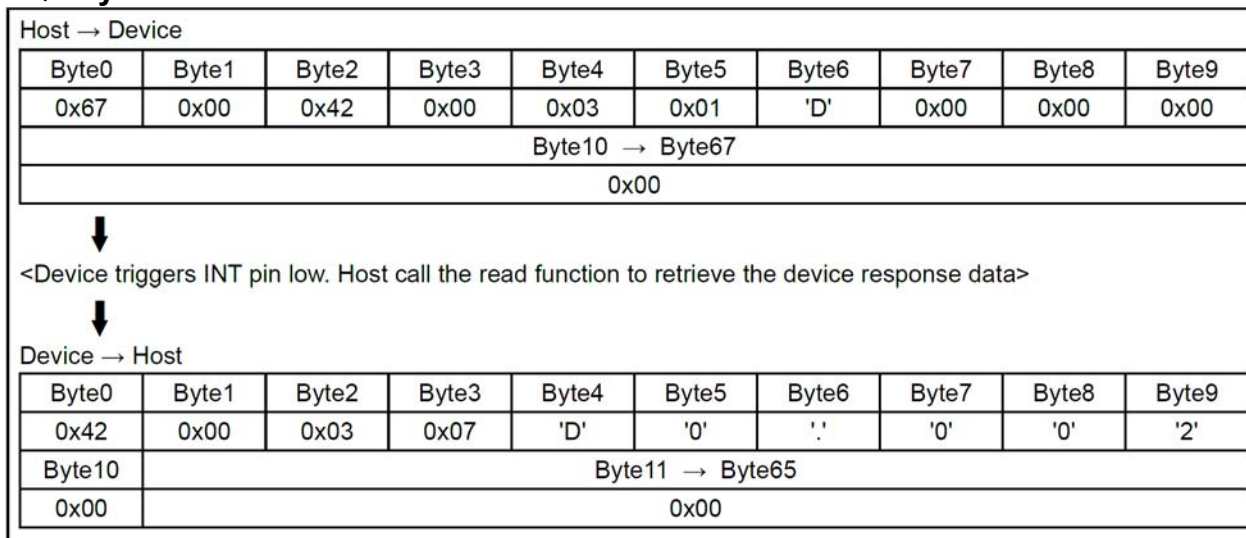

Query controller model name

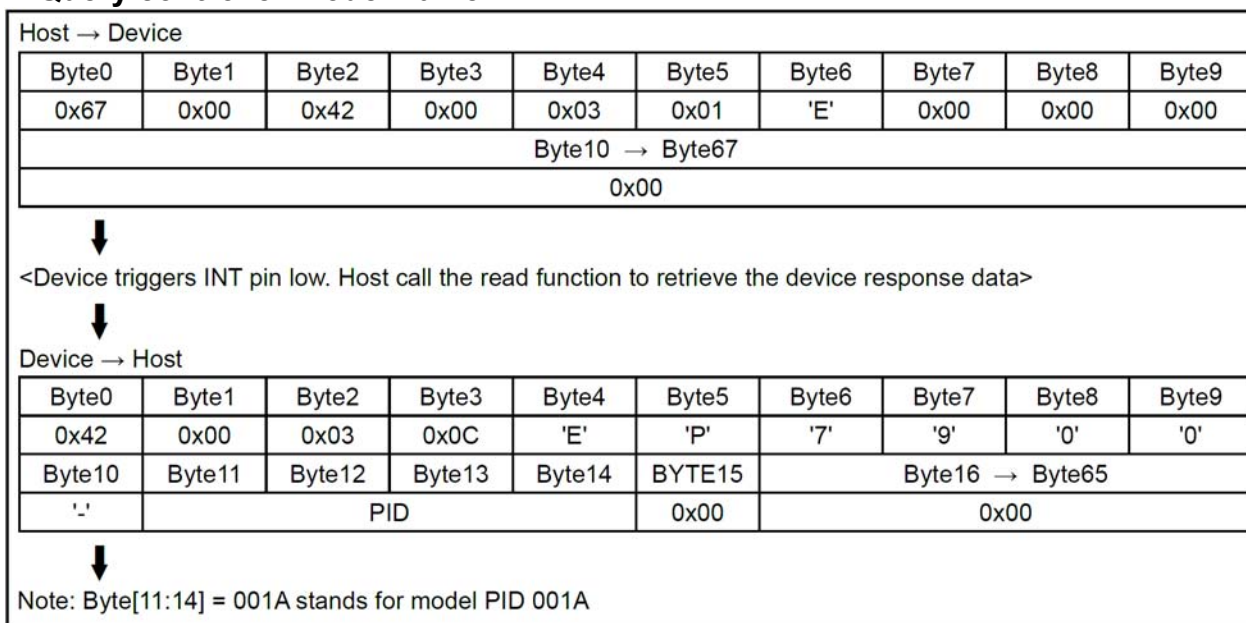

7.8 Power Saving Mechanism

EXC7900 - supports 3 working mode for power saving.

Fully working mode:

After reset, the controller module works at full power working state.

Idle mode:

After EXC7900 receives a software packet from host computer to request MCU entering idle state, this controller module will enter idle state. At idle state, IRQ pin will be released to high state. Host computer can wake up this controller module via generating a falling edge signal at IRQ pin. When controller transfers to fully working mode, it will reply a wakeup command to host.

Set idle command

Host → Device									
Byte0	Byte1	Byte2	Byte3	Byte4	Byte5	Byte6	Byte7	Byte8	Byte9
0x67	0x00	0x42	0x00	0x03	0x04	0x36	0x3F	0x01	T
Byte10 → Byte67									
0x00									

Host computer send this command as above for idle state configuration setting. Where, T means the scanning interval when in idle state. The touch controller will wakeup every that period of time to scan touch screen to check if the touchscreen touched or not. Once it detects sensor touched, the controller will back to fully working state automatically.

↓

The default value of T is 30, the interval = $T \times 0.25 = 7.5\text{ms}$

Sleep mode:

Whenever the host computer wants to deep sleep, it issues a sleep command packet to controller. Once the controller firmware receives such sleep command, it enters deep sleep state and does not response until it wakes up from this sleep state. Only host computer can wake up this device via generating a falling edge signal at IRQ pin.

When controller transfers to fully working mode, it will reply a wakeup command to host.

Set sleep command

Host → Device									
Byte0	Byte1	Byte2	Byte3	Byte4	Byte5	Byte6	Byte7	Byte8	Byte9
0x67	0x00	0x42	0x00	0x03	0x03	0x36	0x3F	0x02	0x00
Byte10 → Byte67									
0x00									

Host computer send above command packet to touch controller device to make the device enter sleep state for power saving.

Wakeup notification command

Once the controller transfers to working state from idle and sleep state, it will trigger INT pin low and reply below command to host.

Byte0	Byte1	Byte2	Byte3	Byte4	Byte5	Byte6	Byte7	Byte8	Byte9
0x42	0x00	0x03	0x03	0x36	0x3F	0x01	0x00	0x00	0x00
Byte10 → Byte65									
0x00									

8.ELIABILITY TEST CONDITIONS

Test Item	Test Conditions	Note
High Temperature Operation	70±3°C ,Dry t=240 hrs	
Low Temperature Operation	-20±3°C, Dry t=240 hrs	
High Temperature Storage	80±3°C , Dry t=240 hrs	1,2
Low Temperature Storage	-30±3°C ,Dry t=240 hrs	1,2
Thermal Shock Test	-20°C ~ 25°C ~ 70°C 30 m in. 5 min. 30 min. (1 cycle) Total 100 cycle(Dry)	1,2
Storage Humidity Test	60 °C, Humidity 90%, 240 hrs	1,2
Vibration Test (Packing)	Sweep frequency : 10 ~ 55 ~ 10 Hz/1min Amplitude : 0.75mm Test direction : X.Y.Z/3 axis Duration : 30min/each axis	2

Note 1 : Condensation of water is not permitted on the module.

Note 2 : The module should be inspected after 1 hour storage in normal conditions (15-35°C , 45-65%RH).

Definitions of life end point :

- Current drain should be smaller than the specific value.
- Function of the module should be maintained.
- Appearance and display quality should not have degraded noticeably.
- Contrast ratio should be greater than 50% of the initial value.

9. GENERAL PRECAUTION

9.1 Use Restriction

This product is not authorized for use in life supporting systems, aircraft navigation control systems, military systems and any other application where performance failure could be life-threatening or otherwise catastrophic.

9.2 Disassembling or Modification

Do not disassemble or modify the module. It may damage sensitive parts inside LCD module, and may cause scratches or dust on the display. AMPIRE does not warrant the module, if customers disassemble or modify the module.

9.3 Breakage of LCD Panel

- (1) If LCD panel is broken and liquid crystal spills out, do not ingest or inhale liquid crystal, and do not contact liquid crystal with skin.
- (2) If liquid crystal contacts mouth or eyes, rinse out with water immediately.
- (3) If liquid crystal contacts skin or cloths, wash it off immediately with alcohol and rinse thoroughly with water.
- (4) Handle carefully with chips of glass that may cause injury, when the glass is broken.

9.4 Electric Shock

- (1) Disconnect power supply before handling LCD module.
- (2) Do not pull or fold the LED cable.
- (3) Do not touch the parts inside LCD modules and the fluorescent LED's connector or cables in order to prevent electric shock.

9.5 Absolute Maximum Ratings and Power Protection Circuit

- (1) Do not exceed the absolute maximum rating values, such as the supply voltage variation, input voltage variation, variation in parts' parameters, environmental temperature, etc., otherwise LCD module may be damaged.
- (2) Please do not leave LCD module in the environment of high humidity and high temperature for a long time.
- (3) It's recommended to employ protection circuit for power supply.

9.6 Operation

- (1) Do not touch, push or rub the polarizer with anything harder than HB pencil lead.
- (2) Use fingerstalls of soft gloves in order to keep clean display quality, when persons handle the LCD module for incoming inspection or assembly.
- (3) When the surface is dusty, please wipe gently with absorbent cotton or other soft material.
- (4) Wipe off saliva or water drops as soon as possible. If saliva or water drops contact with polarizer for a long time, they may cause deformation or color fading.
- (5) When cleaning the adhesives, please use absorbent cotton wetted with a little petroleum benzene or other adequate solvent.

9.7 Mechanism

Please mount LCD module by using mounting holes arranged in four corners tightly.

9.8 Static Electricity

- (1) Protection film must remove very slowly from the surface of LCD module to prevent from electrostatic occurrence.
- (2) Because LCD modules use CMOS-IC on circuit board and TFT-LCD panel, it is very weak to electrostatic discharge. Please be careful with electrostatic discharge. Persons who handle the module should be grounded through adequate methods.

9.9 Strong Light Exposure

The module shall not be exposed under strong light such as direct sunlight. Otherwise, display characteristics may be changed.

9.10 Disposal

When disposing LCD module, obey the local environmental regulations.

9.11 Others

Do not keep the LCD at the same display pattern continually. The residual image will happen and it will damage the LCD. Please use screen saver.

10. OUTLINE DIMENSION

REV	REVISION RECORD	DATE	NAME
0	NEW RELEASE	05-20-16	EMILY

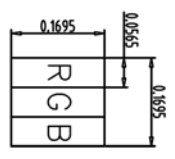

A Block

CN1

1	NC	21	LV3P
2	VDD	22	GND
3	VDD	23	NC
4	VDD_EDID	24	NC
5	SCL_EDID	25	NC
6	SDA_EDID	26	NC
7	NC	27	NC
8	LVON	28	NC
9	LVOP	29	CABC_EN
10	GND	30	NC
11	LV1N	31	NC
12	LV1P	32	NC
13	GND	33	NC
14	LV2N	34	NC
15	LV2P	35	BIST
16	GND	36	NC
17	LVCLKN	37	NC
18	LVCLKP	38	NC
19	GND	39	NC
20	LV3N	40	NC

1	VDD
2	SCL
3	SDA
4	/INT
5	RES
6	GND

I2C interface:

Note:
 1. Unless indicated, Tolerance "±0.5"
 2. LVDS Connector: Starcom/300E40-0010RA-G3 or Equivalent
 3. CTP Connector: P1.0 6Pin/CSA10-06-P-R or Equivalent

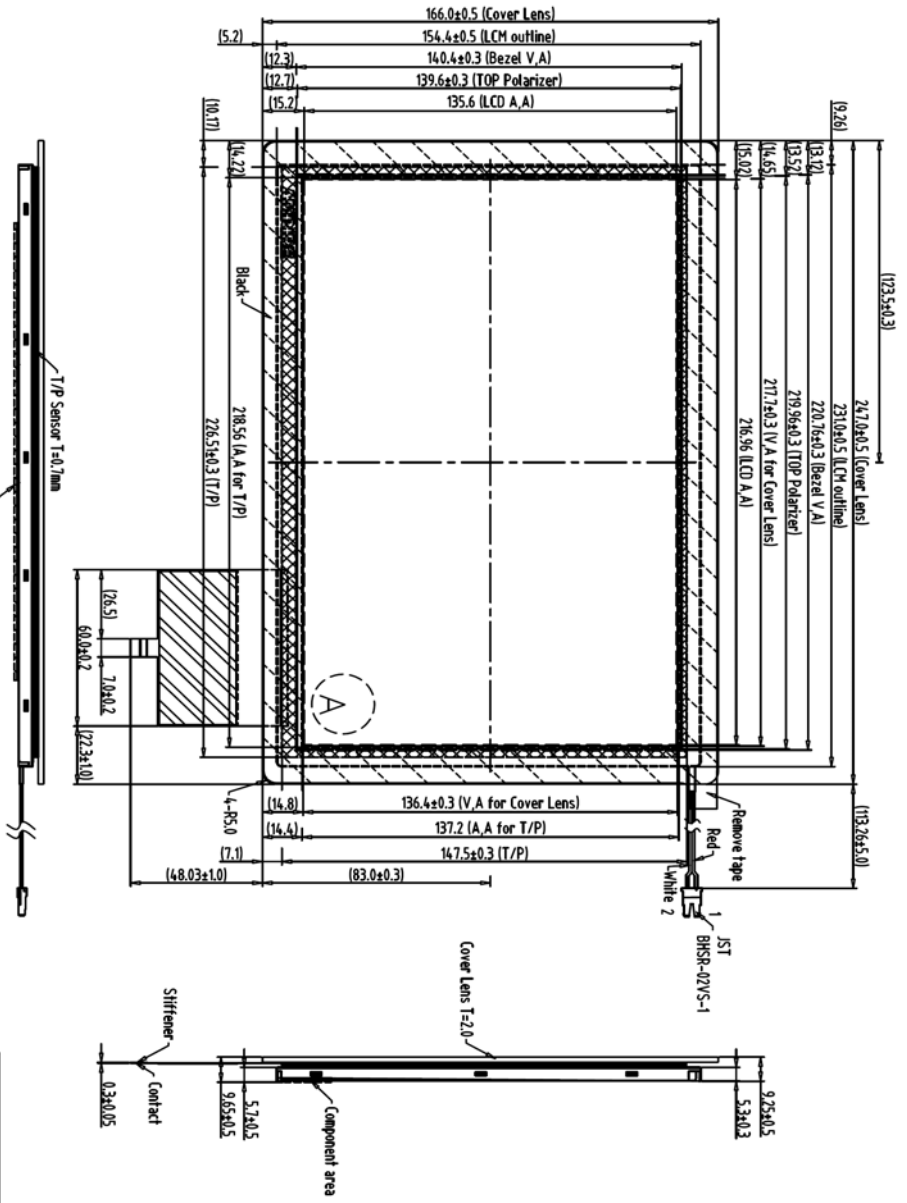

1	1280800NG-00	LCM	7																
2	1280800NB-T	FPC(I2C)	8																
3	EETI	EX3132	9																
4	Cover lens	(247.0x166.0x2.0mm)	10																
5			11																
6			12																

TOLERANCE	GRADIENT	A	B	DIM.	MM	DWG.	EMILY	DATE
				IE NO.		CHK.		DATE
				PARTS NO. LCM	1280800NG-T45	APPD.		DATE

TTTTT	AMPIRE 晶采光电科技
1280800NG-T45	
(10.1")	
DWG. NO. *160571MA	SHEET 1 OF 1

REV	REVISION RECORD	DATE	NAME
0	NEW RELEASE	16-01-16	EMILY

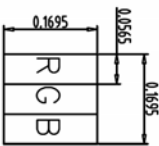

A Block

CN1

1	NC	21	LV3P
2	VDD	22	GND
3	VDD	23	NC
4	VDD_EDID	24	NC
5	SCL_EDID	25	NC
6	SDA_EDID	26	NC
7	NC	27	NC
8	LVON	28	NC
9	LVOP	29	CABC_EN
10	GND	30	NC
11	LV1N	31	NC
12	LV1P	32	NC
13	GND	33	NC
14	LV2N	34	NC
15	LV2P	35	BIST
16	GND	36	NC
17	LVCLKN	37	NC
18	LVCLKP	38	NC
19	GND	39	NC
20	LV3N	40	NC

I2C interface:

1	VDD
2	SCL
3	SDA
4	/INT
5	RES
6	GND

Note:
 1. Unless indicated, Tolerance "±0.5"
 2. LVDS Connector: Starconn/300E40-0010RA-G3 or Equivalent
 3. CTP Connector: P1.0 6Pin/CSA10-06-P-R or Equivalent

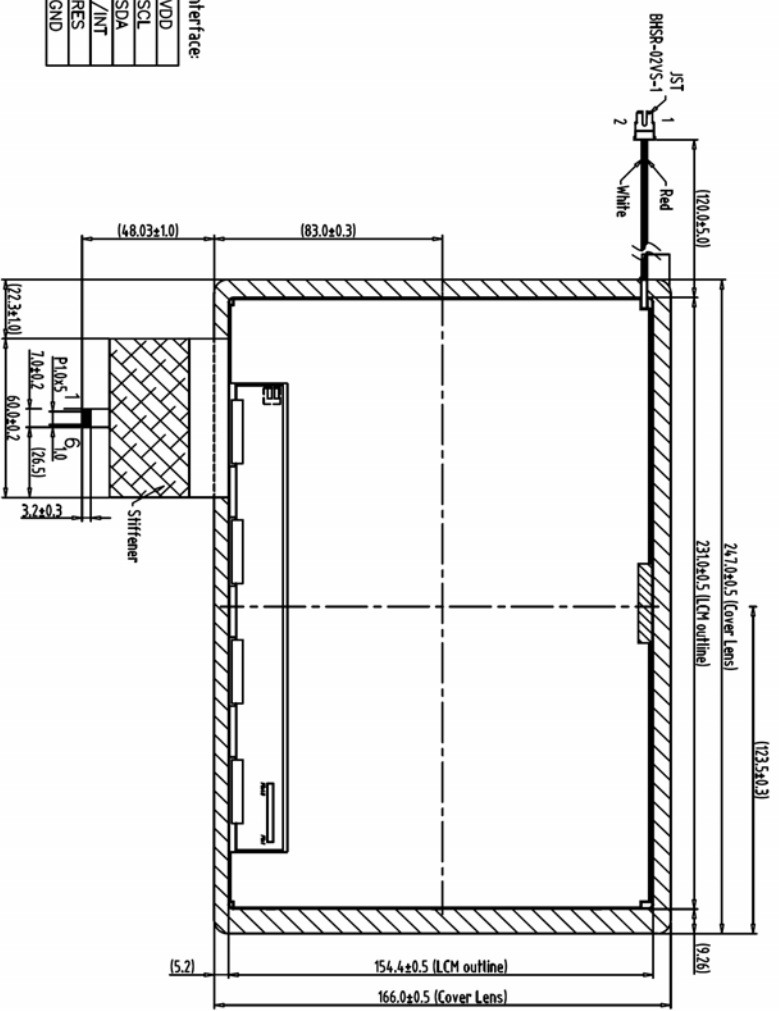

Back view

1	1280800NG-00 LCM	7																	
2	1280800NB-1 FPC(12C)	8																	
3	ETI EX3132	9																	
4	Cover lens (247.0x166.0x2.0mm)	10																	
5		11																	
6		12																	

TOLERANCE GRADE(F)

A

B

DIK.

MM

DWN.

EMILY

DATE

05-20-16

DATE

DATE

DATE

DATE

DATE

DATE

DATE

DATE

AMPIRE 晶采光電科技

1280800NG-T45

(10.1")

DWG. NO. *160572MA

SHEET 1 OF 1