

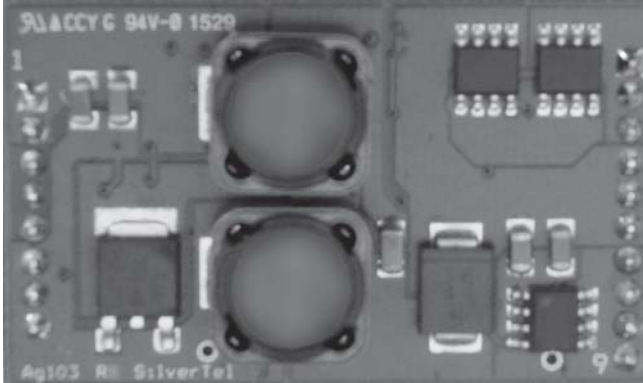

Ag103

Intelligent Sealed Lead Acid Solar Battery Charger
Module



Zwingenstrasse 6-8, A-2380 Perchtoldsdorf
Tel. Vienna +43/(0)1/86 305 - 5000
Fax Vienna +43/(0)1/86 305 - 98
e-mail: office@codico.com
www.codico.com

1 Features

- Multi-Stage Charging
- Solar Panel or DC Input
- Maximum Power Point Tracking (MPPT)
- Very Low Power Consumption
- Wide DC Input Voltage Range
- High Efficiency DC-DC Converter
- Intelligent 'Top-up' Float Charge
- Programmable Charge Current
- Battery Condition Indicator
- Temperature Compensation
- Overload & Short-circuit Protection
- Simple Integration

2 Description

The Ag103 is a micro-processor based intelligent, low cost, sealed lead acid (SLA) battery charging module designed to be used with solar panels. It uses digital technology to optimise the charging of 12V sealed lead acid batteries between 1.2Ah and 12Ah capacity. Using intelligent charging techniques, including maximum power point tracking, the Ag103 technology maximises both battery lifetime and the amount of power derived from the solar panel.

The Ag103 can take a dc input range of 9V to 36V DC, this gives great flexibility allowing the system and charger to use a variety of power levels of solar panels, or a low cost power supply.

Table of Contents

1 Features 1

2 Description..... 1

 2.1 Table of Figures..... 2

Ag103 Product Selector 3

3 Pin Description 4

4 Functional Description 6

 4.1 Operation..... 6

 4.2 Input 7

 4.3 Capacity Select..... 8

 4.4 Load Enable 9

 4.5 Thermal Compensation 9

 4.6 Status Output..... 11

 4.6.1 Mode 0 – Bulk Charge Operation 11

 4.6.2 Mode 1– Float Charge..... 12

 4.6.3 Mode 2 – Over Current..... 12

 4.6.4 Mode 3 – Over Temperature 12

 4.6.5 Mode 4 – Disconnected battery..... 12

 4.6.6 Mode 5 - Input Voltage Removed/ No Solar Power 12

5 Typical Application..... 14

6 Operating Temperature Range 16

7 Protection 16

 7.1 Over Current & Short Circuit Protection..... 16

 7.2 Over Temperature Protection 16

 7.3 Low Battery Terminal Voltage Protection 16

 7.4 Deep Discharge Protection..... 16

 7.5 Battery Reversal 16

8 Features 17

 8.1 MPPT- Maximum Power Point Tracking..... 17

9 Electrical Characteristics 18

 9.1 Absolute Maximum Ratings* 18

 9.2 Recommended Operating Conditions..... 18

 9.3 DC Electrical Characteristics* 18

10 Package 19

2.1 Table of Figures

Figure 1: Block Diagram with External Components..... 3

Figure 2: Ag103 DIL Package Format 5

Figure 3: Basic Ag103 Charge Profile..... 6

Figure 4: Input Connections – Solar, DC or AC Input 7

Figure 5: Capacity Select..... 8

Figure 6: Output Adjustment 10

Figure 7: STAT Output Configurations..... 11

Figure 8: STAT Output Timing 13

Figure 9: Typical Application - Permanent Load 14

Figure 10: Typical Application - Battery Back Up..... 15

Figure 11: MPPT of a 20W solar panel..... 17

Ag103 Product Selector

Part Number	Input Voltage	Output Voltage	Battery Capacity	Marking	Package
Ag103*	9V to 36V	12V	1.2Ah to 12Ah	Ag103	DIL

* The Ag103 fully meets the requirements of the RoHS directive 2002/95/EC on the restriction of hazardous substances in electronic equipment.

Table 1: Ordering Information

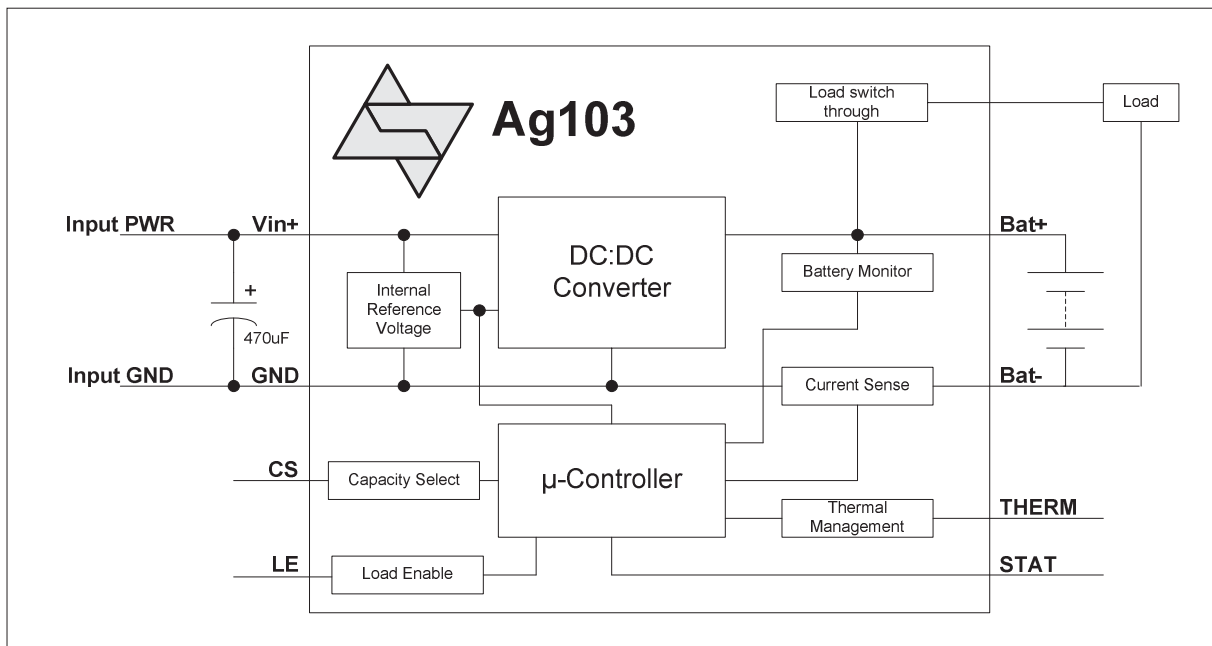

Figure 1: Block Diagram with External Components

3 Pin Description

Pin	Name	Description
1	VIN+	Positive Supply (Input). This pin connects to a positive dc supply (9V to 36V).
2	VIN+	Positive Supply (Input). This pin connects to a positive dc supply (9V to 36V).
3	CS	Capacity Select (Input). This pin connects to an external resistor to set the capacity of the battery to be charged (1.2Ah to 12Ah).
4	STAT	Charge Status (Output). This output pin is used to indicate the system status.
5	LE	Load Enable (Input). Connect this pin to GND via a 2k resistor to permanently connect the battery to the load. Leave open circuit for battery back up mode.
6	GND	Ground Return (Input). This pin connects to the ground return of the power supply.
7	GND	Ground Return (Input). This pin connects to the ground return of the power supply.
8	GND	Ground Return (Input). This pin connects to the ground return of the power supply.
9	BAT-	Battery Negative (Output). The output pin connects to the battery negative terminal. It must NOT be connected directly to the GND pin.
10	BAT-	Battery Negative (Output). The output pin connects to the battery negative terminal. It must NOT be connected directly to the GND pin.
11	BAT-	Battery Negative (Output). The output pin connects to the battery negative terminal. It must NOT be connected directly to the GND pin.
12	THERM	Thermistor (Input). The pin can be connected to an external thermistor to add temperature compensation (if required).
13	BAT+	Battery Positive (Output). The output pin connects to the battery positive terminal.
14	BAT+	Battery Positive (Output). The output pin connects to the battery positive terminal.
15	BAT+	Battery Positive (Output). The output pin connects to the battery positive terminal.
16	Load Output	Load Output (Output). The Load output pin connects the battery positive terminal to the users load.
17	Load Output	Load Output (Output). The Load output pin connects the battery positive terminal to the users load.
18	Load Output	Load Output (Output). The Load output pin connects the battery positive terminal to the users load.

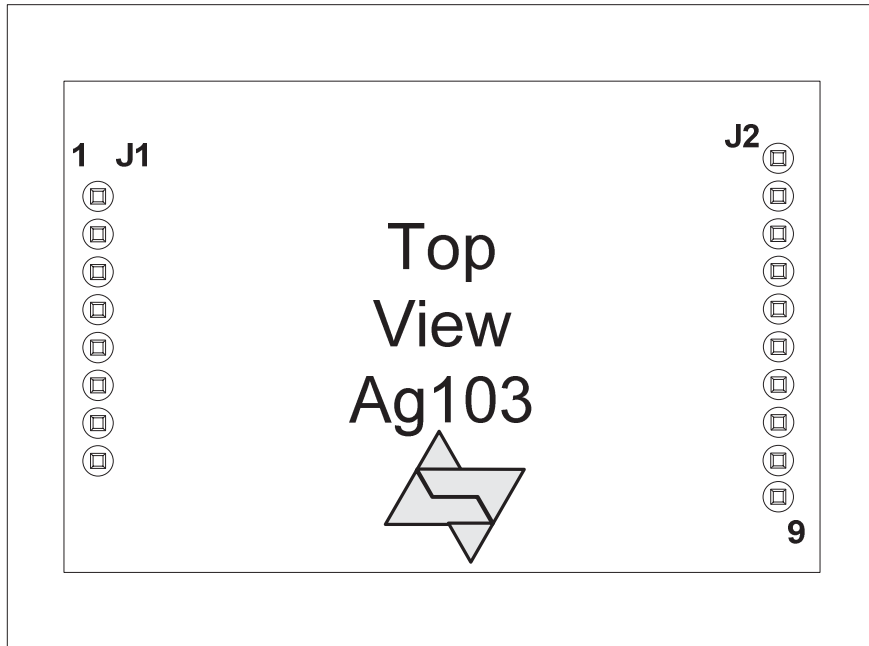

Figure 2: Ag103 DIL Package Format

4 Functional Description

4.1 Operation

In many safety critical systems it is essential that the battery is charged quickly with no stress or damage. Battery manufacturers also recommend using multi-stage charging to reduce the stress on the battery while giving the shortest possible charge time. The Ag103 achieves this using an optimum multi-stage charge cycle, shown in Figure 3.

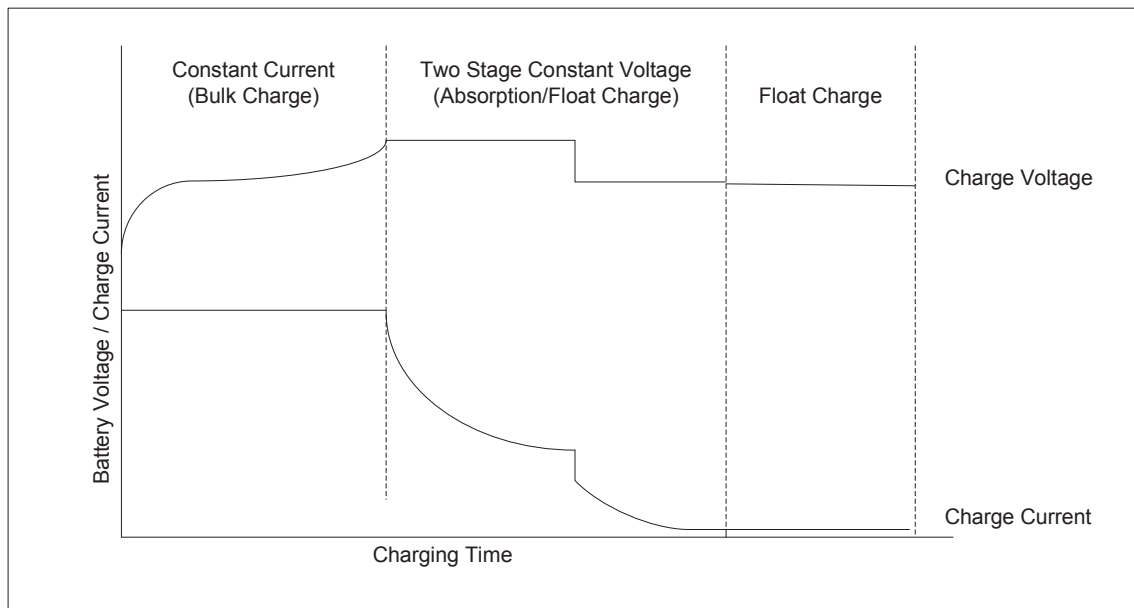

Figure 3: Basic Ag103 Charge Profile

The Ag103 implements the ideal charging cycle by applying a higher bulk charge voltage for 70% - 80% of the charge cycle and a lower absorption charge voltage for the remaining 20% - 30%. This is done to prevent the battery from gassing as it approaches full charge.

Once the battery has reached the optimum level, the Ag103 will maintain an accurate float voltage to keep the battery topped up.

The charge profile can be further optimised by using thermal compensation (see Section 4.5).

4.2 Input

The Ag103 can take either a solar panel input or a very wide dc input range of 9Vdc to 36Vdc, making this module extremely flexible. For stable operation it is recommended to fit a 470 μ F capacitor across the input pins, this should be placed as close to these pins as possible.

The Ag103 can also be powered from an AC power supply with the addition of an external bridge rectifier. It is important that the rectified voltage across the input pins is within the 9Vdc to 36Vdc limits, Figure 4 shows examples of these inputs.

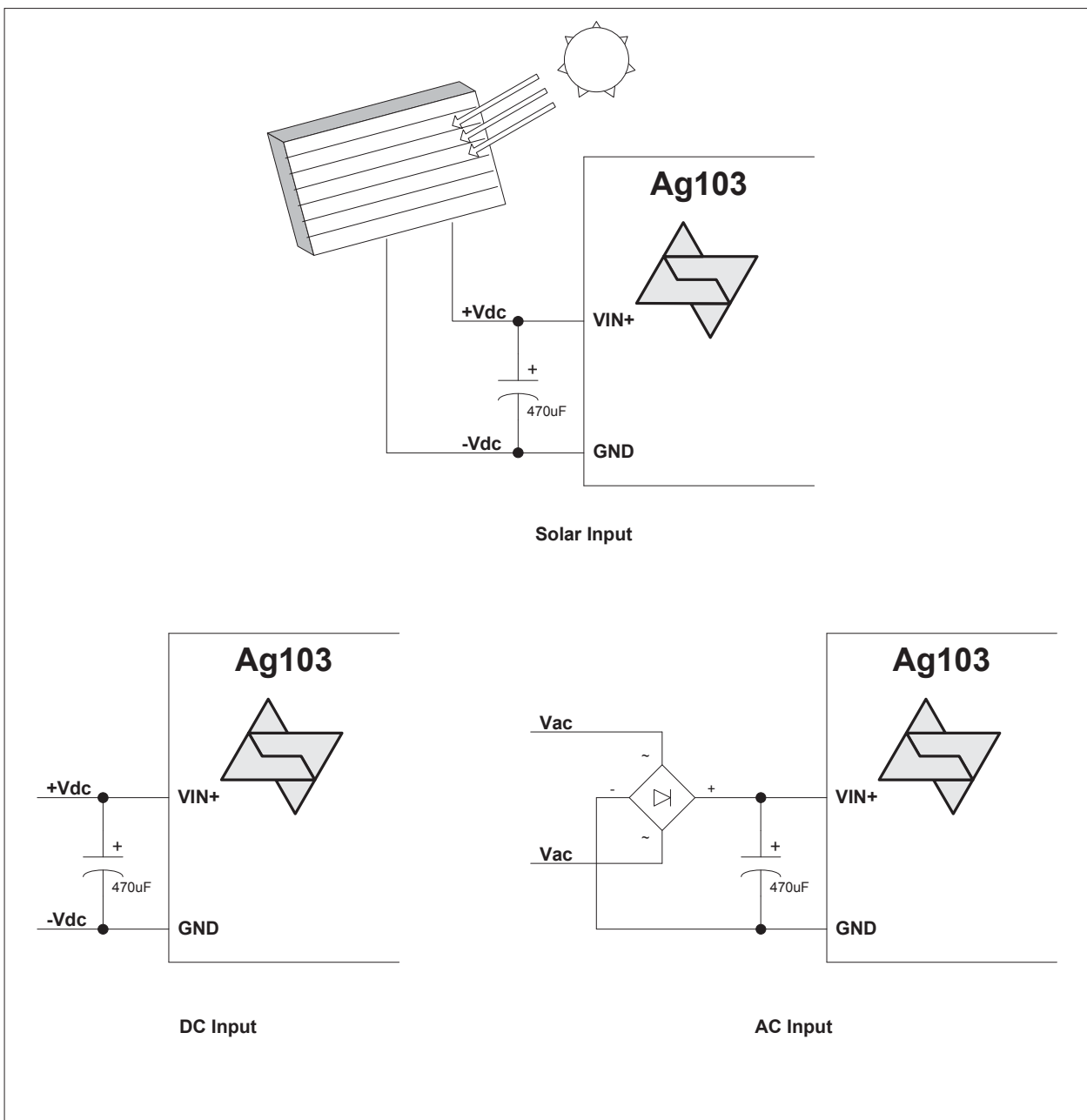

Figure 4: Input Connections – Solar, DC or AC Input

For a solar panel input Table 2 below shows various 12V* panel sizes that can be chosen to charge different size batteries.

Panel Power (W)	Panel Current (A)	Matched battery Size (optimum)	Maximum battery size panel can charge
5W	0.29	1.2Ah	2.8Ah
10W	0.58	2.3Ah or less	5.8Ah
20W	1.14	4Ah or less	11Ah
30W	1.74	7Ah or less	17Ah
40W	2.33	9Ah or less	23Ah
50W	2.85	12Ah or less	28Ah

Table 2: Panel Selection

* Majority of panels are referred to as 12V panels but their open circuit voltage is 21V.

4.3 Capacity Select

The Ag103 is capable of being programmed to charge a range of SLA batteries from 1.2Ah up to 12Ah, by connecting a resistor between the CS pin and the GND pin, see Figure 5.

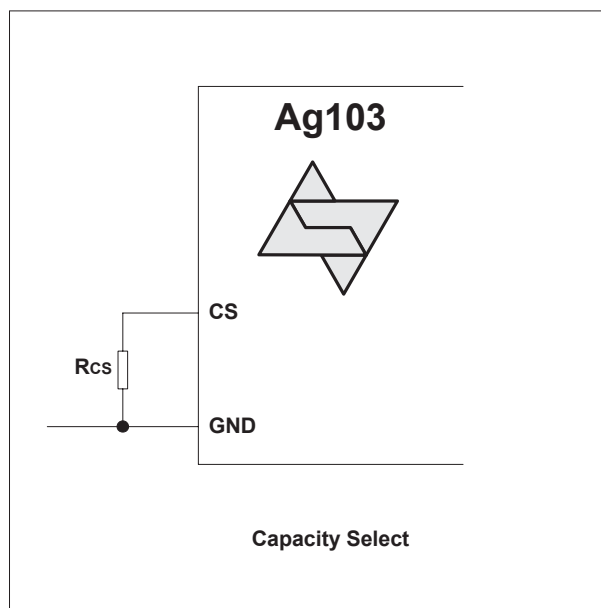

Figure 5: Capacity Select

The CS pin has an internal pull up resistor to a voltage reference which sets the voltage on this pin. This voltage is measured at start-up and the optimum charge profile for the battery is programmed. The value of R_{CS} is shown in Table 3.

Battery Capacity (Ah)	R _{CS} Resistance (Ohms)*	Min Input Voltage (V)	Voltage at the CS Pin (V)	Bulk Charge Current Limit (A) ±10%
1.2	1K ±1%	9	0.3	0.3
2	2K ±1%	9	.55	0.5
2.1	3K ±1%	9	.76	0.525
2.3	3K9 ±1%	9	.93	0.575
2.8	4K7 ±1%	9	1.05	0.7
3.2	6K2 ±1%	12	1.26	0.8
4	6K8 ±1%	12	1.30	1
7	7K5 ±1%	12	1.37	1.2
12	9K1 ±1%	12	1.52	1.2

Table 3: Value of R_{CS}

* To prevent damaging the battery it is important that the correct value of R_{CS} is set. If R_{CS} is not fitted, then the Ag103 will default to 1.2Ah capacity.

4.4 Load Enable

The Ag103 can either connect the battery constantly to the load by connecting a 2k resistor between LE and GND, see Figure 9, or it can be used in a battery back up mode where the battery is only connected to the load if the internal μ -controller detects the input has been disconnected, or the panel voltage has dropped below 9V. This mode is selected by leaving the LE open circuit, see figure 10.

4.5 Thermal Compensation

The optimum terminal voltage for the charging process is also dependent on battery temperature. This is because the electrochemical activity is affected by temperature changes. Therefore, as the temperature rises, the charging voltage should be reduced to prevent overcharge. Likewise as the temperature falls, the charge voltage should be increased to avoid undercharge. In order to maximise the life of the battery the use of temperature compensation is recommended.

The Ag103 makes this easy to implement with only the addition of a low cost Thermistor. The Ag103 measures the THERM pin and will automatically adjust the charge profile to compensate for any changes in battery temperature.

A typical recommended value for TH1 as shown in Figure 6 is a 47K NTC (Negative Temperature Coefficient) resistor with B25/50 ~4000K. These are inexpensive and readily available in surface mount or bead format. For correct operation the Thermistor must be in physical contact with the battery.

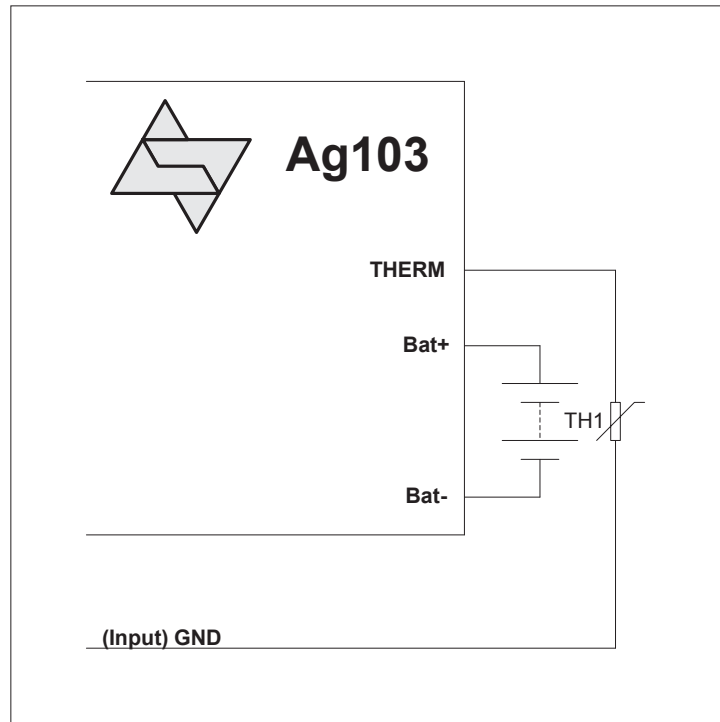

Figure 6: Output Adjustment

When using thermal compensation, if the battery temperature exceeds 50°C, the Ag103 will shut-down the DC-DC converter and the output status indicator (STAT) will report an over temperature error.

The Ag103 will default to a 25°C charge profile if TH1 is not fitted.

4.6 Status Output

The Ag103 has a status indication output pin 'STAT'; that can be connected to a μ -controller input for full status monitoring or can be used with an LED as an indicator (as shown in Figure 7).

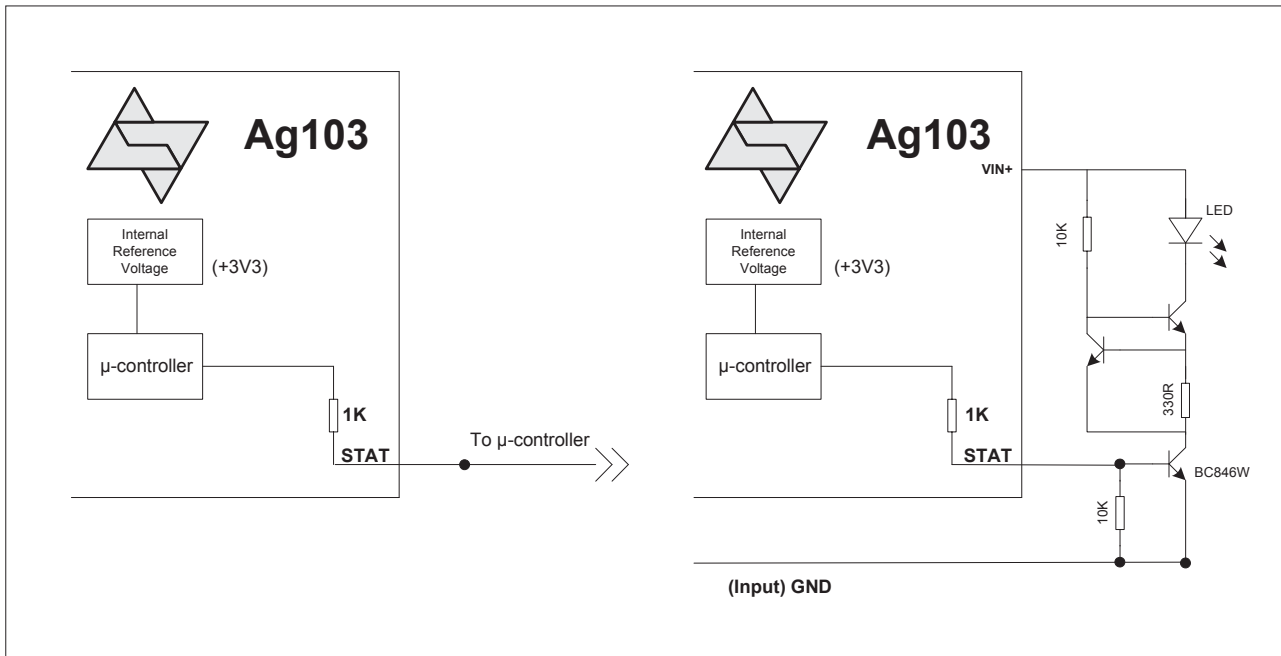

Figure 7: STAT Output Configurations

Table 4, shows the different mode conditions of the Ag103: -

Mode	Status Mode	STAT Output
0	Bulk Charge Operation	Steady State 'Logic 1'
1	Float Charge	50% 'Logic 1' 50% 'Logic 0'
2	Over Current Error	1 Pulse
3	Over Temperature Error	2 Pulses
4	Disconnected Battery Error	3 Pulses
5	Input Voltage Removed / No Solar Power	Steady State 'Logic 0'

Table 4: STAT Output Conditions

4.6.1 Mode 0 – Bulk Charge Operation

Once the Ag103 has checked the battery capacity and sees a 12V battery connected it will power up and the 'STAT' pin will output a steady state 'logic 1'.

The Ag103 will continue to output this state until the battery has reached it's 80% charge before switching to float charge and entering Mode 1.

4.6.2 Mode 1– Float Charge

After the battery has reached it's 80% charge the Ag103 will change it's charging status to float charge by dropping it's terminal voltage down to ~13.65V. The 'STAT' pin will drop to a logic 0 for 1s and then back to a logic 1 for 1s. This cycle will repeat itself over the period of its float charge.

4.6.3 Mode 2 – Over Current

If an output over current condition is detected, the Ag103 will shutdown its DC-DC converter and will go into Mode 2. The STAT pin will drop to a logic 0 for 100ms, followed by a logic 1 for 100ms before returning to a logic 0. The Ag103 will then reset and wait 2 seconds before re-attempting to power up. If the over current is still there when trying to power up, the Ag103 will immediately shut back down and repeat the process. Once the over current has been removed the Ag103 will return to Mode 0 (bulk charge operation).

4.6.4 Mode 3 – Over Temperature

If a battery over temperature condition occurs, the Ag103 will shutdown its DC-DC converter to protect the battery and enter Mode 3. The STAT pin will drop to a logic 0 for 100ms before generating two logic 1 pulses, with a 100ms mark and 100ms space. This will repeat over a 2s period until the battery temperature has dropped below 50°C (the maximum operating temperature). Once the battery temperature has dropped below 50°C the Ag103 will return to Mode 0 (bulk charge operation).

4.6.5 Mode 4 – Disconnected battery

If the battery is disconnected or there is no battery present at power up, the Ag103 will shutdown its DC-DC converter, go into Mode 4 and output three 100ms logic 1 pulses, with a 100ms mark and 100ms space. This will repeat over a 2s period until a 12V battery is connected. When a 12v battery is connected the Ag103 will go into Mode 0 (bulk charge operation).

4.6.6 Mode 5 - Input Voltage Removed/ No Solar Power

When the input voltage is removed or the solar panel can no longer provide any power to the Ag103, the STAT pin will output a logic 0 until power has been reconnected or the panel can provide enough power to charge the connected battery.

Figure 8 shows the timing of the STAT output in more detail: -

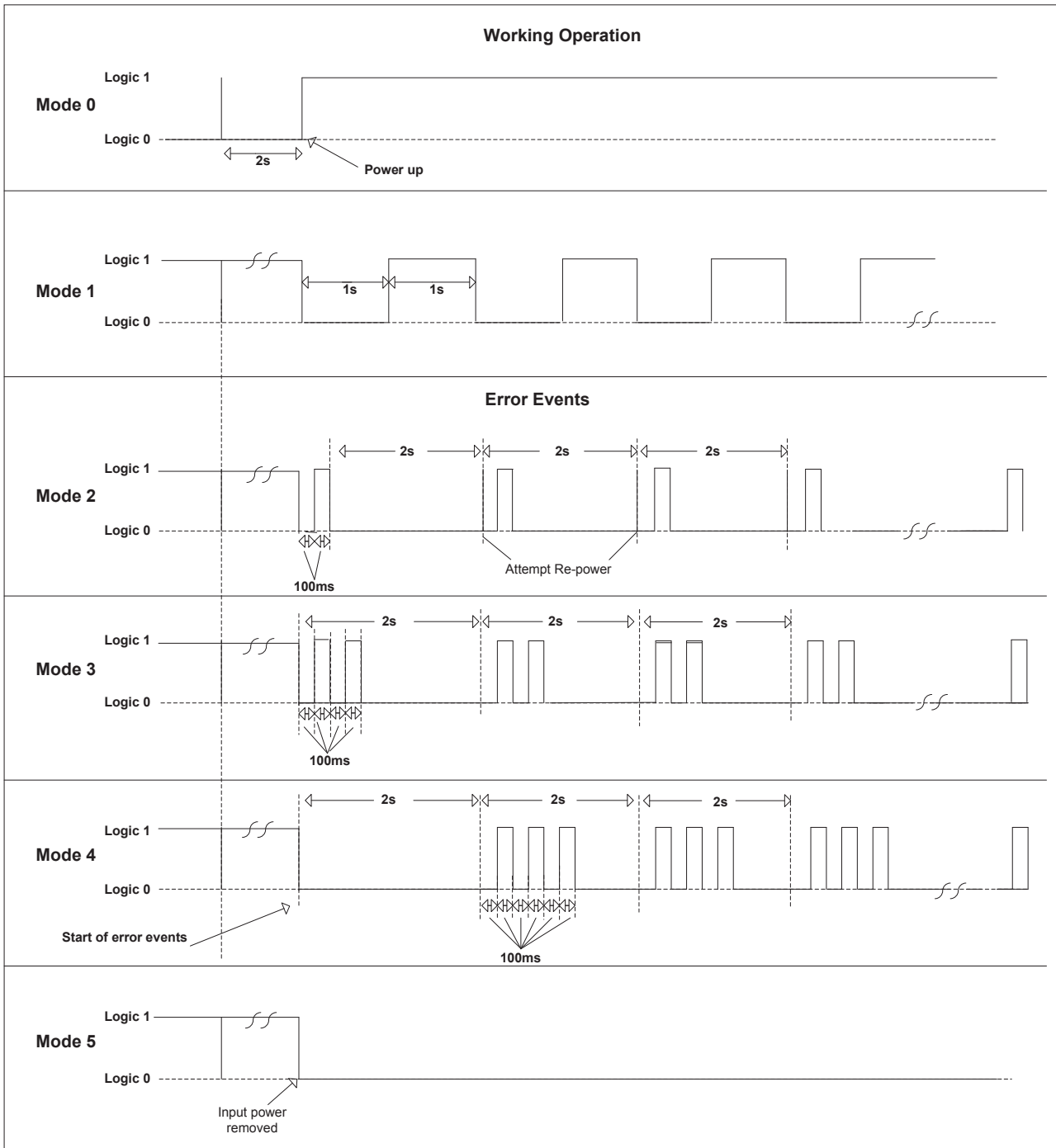

Figure 8: STAT Output Timing

5 Typical Application

The Ag103 is ideal for solar powered applications such as roadside warnings, parking meters and LED street lighting. Figure 9 shows a very simple method of connecting the Ag103 for this application where the power is permanently connected to the load. However if your application requires only to be used as a battery back up system, for example emergency lighting, alarm systems, door access control and UPS, then a typical application is shown in figure 10.

C1 should be positioned as close to the input pins as possible and TH1 should be in physical contact with the battery. It is also very important that the GND and Bat- pins are not connected together as this could permanently damage the battery.

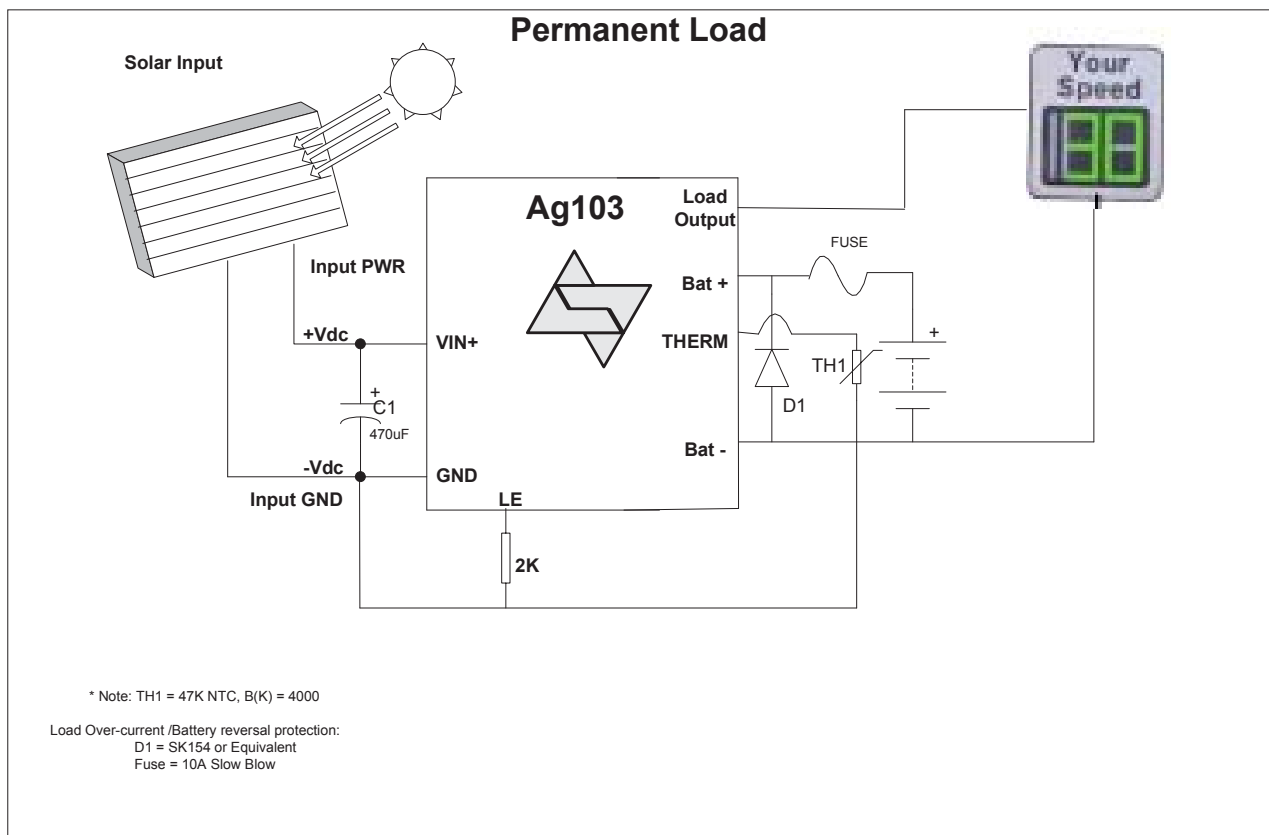

Figure 9: Typical Application - Permanent Load

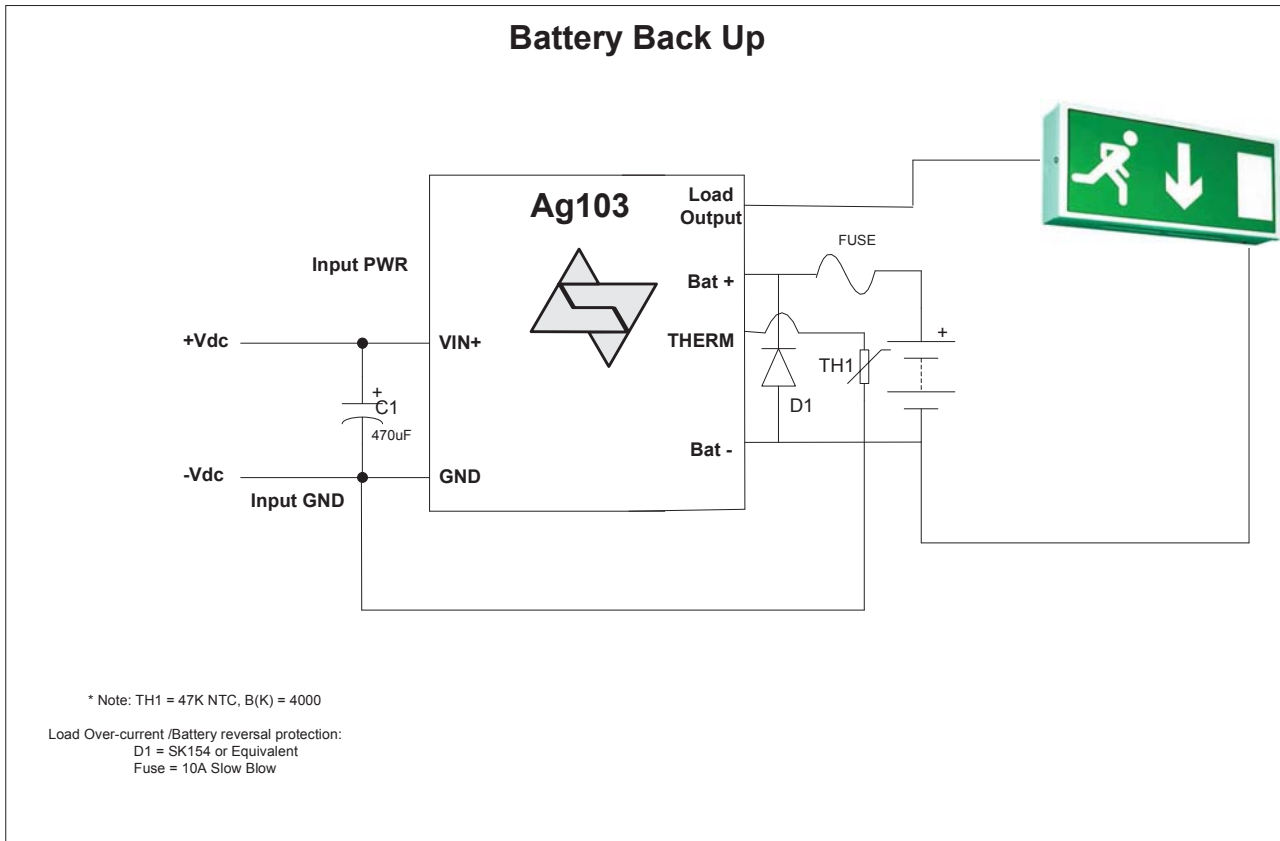

Figure 10: Typical Application - Battery Back Up

6 Operating Temperature Range

For most applications the Ag103 will be positioned close to the battery and the maximum operating temperature will be limited by the battery to 50°C. However if the battery is being charged remotely, then the Ag103 can be operated from -20°C to +70°C.

7 Protection

The Ag103 offers four primary protection circuits: -

7.1 Over Current & Short Circuit Protection

The Ag103 output has over current and short circuit protection. This is triggered when the output current exceeds 200mA above the bulk charge current shown in Table 3. If an over current fault is detected, the Ag103 will shut-down the DC-DC converter and the STAT output will report an over current error.

7.2 Over Temperature Protection

This can only be activated if the thermal compensation thermistor is fitted. If the battery temperature exceeds 50°C, the Ag103 will shut-down the DC-DC converter and the STAT output will report an over temperature error.

7.3 Low Battery Terminal Voltage Protection

If the battery terminal voltage is <7V, the Ag103 Status output will report Mode 4 and the Ag103 will remain idle and wait until a 12V battery has been connected.

This is primarily to protect the user from accidentally connecting a 6V battery to the Ag103. It also protects the Ag103 from being connected to a damaged or a deep discharged battery.

7.4 Deep Discharge Protection

The Ag103 constantly monitors the terminal voltage of the battery. If the load connected draws too much power or has been constantly drawing power from the battery causing the terminal voltage to fall below 10.5V, the Ag103 will disconnect the load from the battery to stop it being deep discharged. The Ag103 will only allow the load to be reconnected once the terminal voltage on the battery recovers to 12.5V or higher.

7.5 Battery Reversal

The Ag103 does not provide battery reversal protection, however Figure 9 shows a simple method of providing this safety feature. This also provides protection for an over-current or short on the Load Output pin.

8 Features

8.1 MPPT- Maximum Power Point Tracking

The Ag103 has MPPT built in which keeps the solar panel in a state where it can produce the maximum amount of power it is capable of. This optimises the amount of power harvesting from a solar panel, such that the maximum power is being delivered to charge the battery.

The Ag103 constantly monitors the terminal voltage of a 12V solar panel and the amount of current it is drawing. If there is a cloudy day or limited amount of sun the solar panels voltage automatically folds over and the power output drops. The Ag103 tracks this drop and alters its charging profile/power to ensure it gets the maximum power out of the solar panel, thereby providing the maximum charge to the battery that can be achieved.

Figure 11 below shows an example of the Maximum Power Point of a 20W panel.

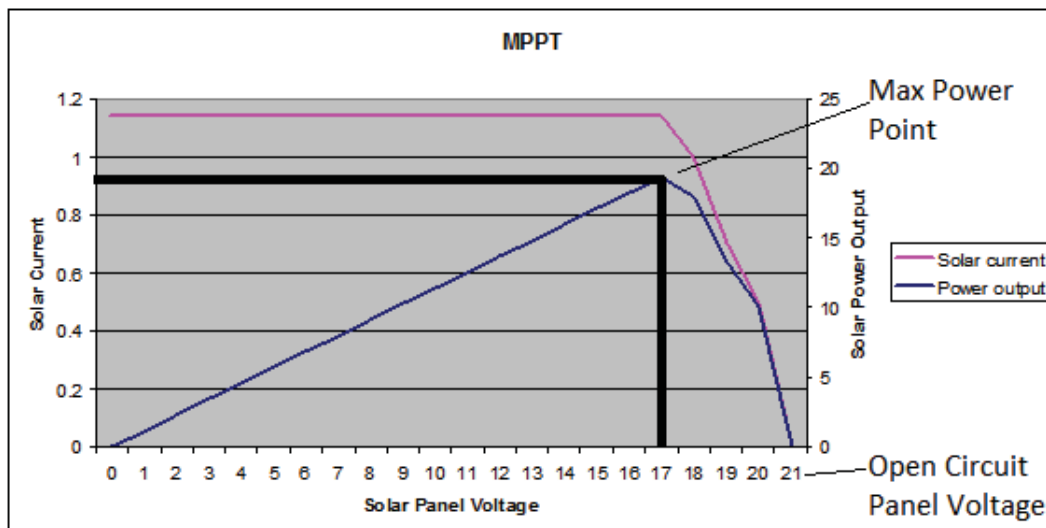

Figure 11: MPPT of a 20W solar panel



Zwingenstrasse 6-8, A-2380 Perchtoldsdorf
Tel. Vienna +43/(0)1/86 305 - 5000
Fax Vienna +43/(0)1/86 305 - 98
e-mail: office@codico.com
www.codico.com

9 Electrical Characteristics

9.1 Absolute Maximum Ratings*

	Parameter	Symbol	Min	Max	Units
1	DC Supply Voltage	V_{CC}	-0.3	40	V
2	Storage Temperature	T_S	-40	+100	°C

*Exceeding the above ratings may cause permanent damage to the product. Functional operation under these conditions is not implied. Maximum ratings assume free airflow.

9.2 Recommended Operating Conditions

	Parameter	Symbol	Min	Typ	Max	Units
1	DC Input Supply Voltage	V_{IN}	9	12	36	V
2	Solar Input Voltage (open circuit)	V_{IN}		21		V_{OC}
3	Operating Temperature	T_{OP}	-20	25	70†	$T_a / ^\circ C$

†See Section Operating Temperature Range

9.3 DC Electrical Characteristics*

	DC Characteristic	Sym	Min	Typ*	Max	Units	Test Comments
1	Bulk Charge Constant Current	I_{OUT}		See Table 3		A	
2	Absorption Charge Voltage 1	$V_{OUT1}\ddagger$	14.2	14.4	14.6	V	
3	Float Charge Voltage	$V_{OUT2}\ddagger$	13.5	13.65	13.8	V	
4	STAT Output Low Voltage Output High Voltage	V_{OL} V_{OH}	3.3		0.5	V V	
5	Output Ripple and Noise (at the battery terminal)	V_{RN}		50		mVp-p	12Ah battery
6	DC-DC Converter Efficiency	EFF_{DC}		87		%	At 12V-18V input
7	Charger Efficiency	EFF_{BAT}		82		%	
8	Short-Circuit Duration	T_{SC}			∞	sec	
9	Load Output	$I_{L_{OUT}}$			7	A	10A Fuse**

*Typical figures are at 25°C with a nominal input voltage = 12V and are for design aid only. Not Guaranteed

** Fuse to be fitted for protection against over current on the Load output pin. (see figures 9)

‡Measured between the GND and the BAT+ pins



Zwingenstrasse 6-8, A-2380 Perchtoldsdorf
Tel. Vienna +43/(0)1/86 305 - 5000
Fax Vienna +43/(0)1/86 305 - 98
e-mail: office@codico.com
www.codico.com

10 Package

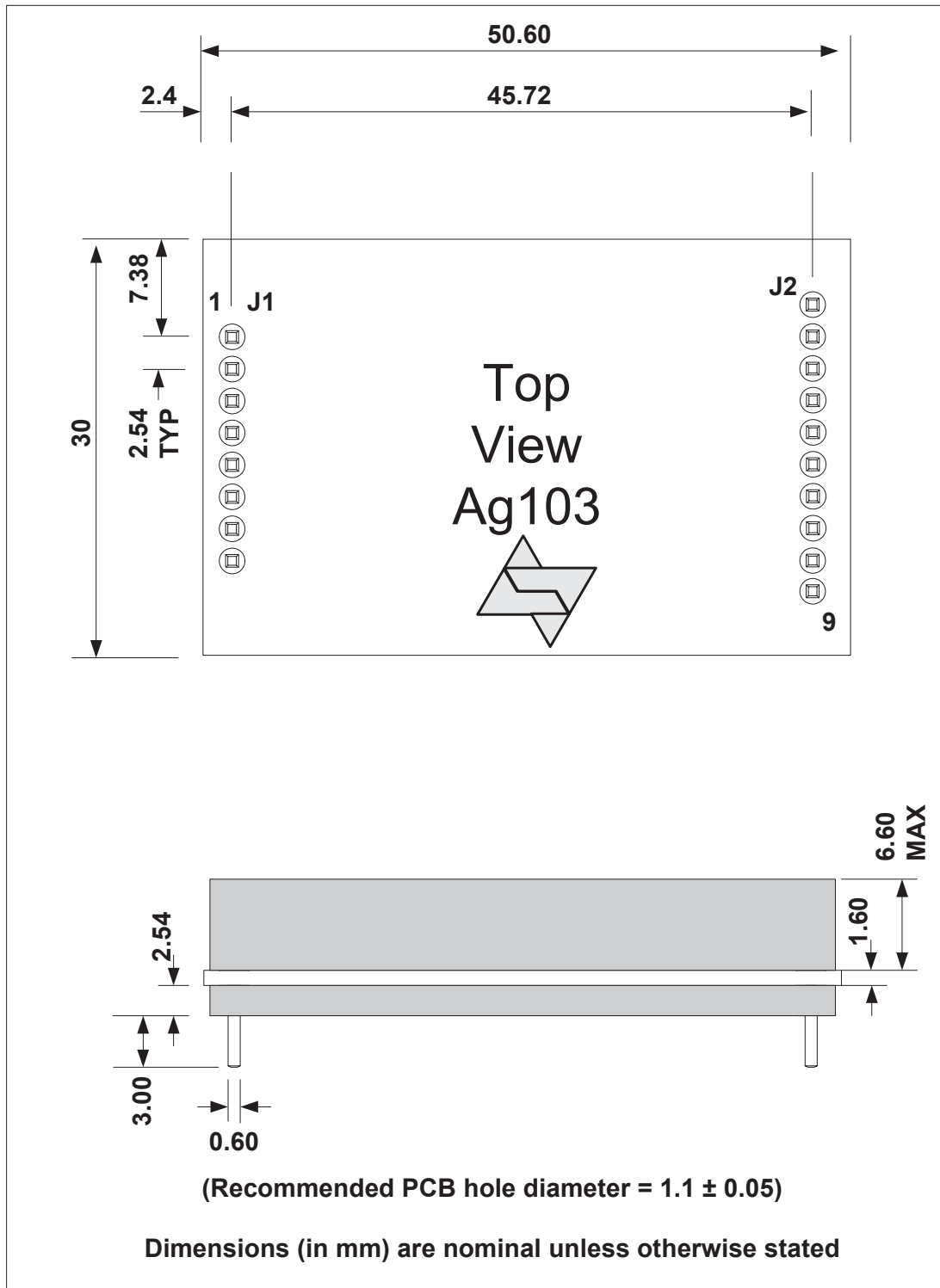

Information published in this datasheet is believed to be correct and accurate. Silver Telecom assumes no liability for errors which may occur or for liability otherwise arising out of use of this information or infringement of patents which may occur as a result of such use. No license is granted by this document under patents owned by Silver Telecom or licensed from third parties by Silver Telecom. The products, their specification and information appearing in this document are subject to change by Silver Telecom without notice.