



晶采光電科技股份有限公司
AMPIRE CO., LTD.

SPECIFICATIONS FOR LCD MODULE

CUSTOMER	
CUSTOMER PART NO.	
AMPIRE PART NO.	AM-12801024ATMQW-00H
APPROVED BY	
DATE	

Approved For Specifications

Approved For Specifications & Sample

AMPIRE CO., LTD.

**Building A., 4F., No.116, Sec. 1, Sintai 5th Rd., Xizhi Dist,
New Taipei City 221, Taiwan (R.O.C.)**

新北市汐止區新台五路一段 116 號 4 樓(東方科學園區 A 棟)

TEL:886-2-26967269 , FAX:886-2-26967196 or 26967270

APPROVED BY	CHECKED BY	ORGANIZED BY

RECORD OF REVISION

Revision Date	Page	Contents	Editor
2015/6/29	-	New Release	Lawlite

1. Features

17.0 inch Amorphous-TFT-LCD (Thin Film Transistor Liquid Crystal Display) module.
This module is composed of a 17.0" TFT-LCD panel, LCD driver and backlight unit.

2. PHYSICAL SPECIFICATIONS

Item	Specifications	Remark
LCD size	17.0 inch(Diagonal)	
Number of Pixels	1280(H) × 1024(V)	
Display mode	Normally white, TN	
Number of Colors	16.7M (6Bit+HFRC)	
Pixel pitch	0.264(W) × 0.264(H)	
Active area	337.92(W) × 270.336(H)	
Module size	358.5 × 296.5 × 12.9 (typ)	
Surface treatment	Anti-Glare, 3H	
Viewing Angle	160 /140(Typ.)	
Backlight	White LED	
Color arrangement	RGB vertical strip	

3. ABSOLUTE MAXIMUM RATINGS

ITEM	SYMBOL	MIN.	MAX.	UNIT	REMARK
Power Supply Voltage for LCD	VCC	0	6.0	V	
Logic Input Voltage	VI	0	6.0	V	
Backlight Power Supply Voltage	VLED	0	15	V	
Backlight ON-OFF Voltage	LED_EN	0	6	V	
Backlight Dimming Control Input Voltage	LED_PWM	0	6	V	
LED Forward voltage	VF	2.8	6.0	V	1). 2)
LED Forward current	IF	--	6.0	mA	
Operation Temperature	Top	-30	80	°C	3). 4). 5). 6).
Storage Temperature	Tstg	-30	80	°C	3). 4). 5). 6).

[Note]

- 1).Product life-time relate to LED, please operate production follow statement at page 8“(2)back light”.
- 2).When LED current over the definition of operating current ,product life-time will decay rapidly or operate unusual.
- 3) The relative temperature and humidity range are as below sketch, 90%RHMax.($T_a \leq 40^\circ\text{C}$). 4).The maximum wet bulb temperature $\leq 39^\circ\text{C}$ ($T_a > 40^\circ\text{C}$) and without dewing.
- 5).If you use the product in an environment which over the definition of temperature and humidity too long to effect the result of eye-etching.
- 6) If you operate the product in normal temperature range, the center surface of front side panel should be under 80°C

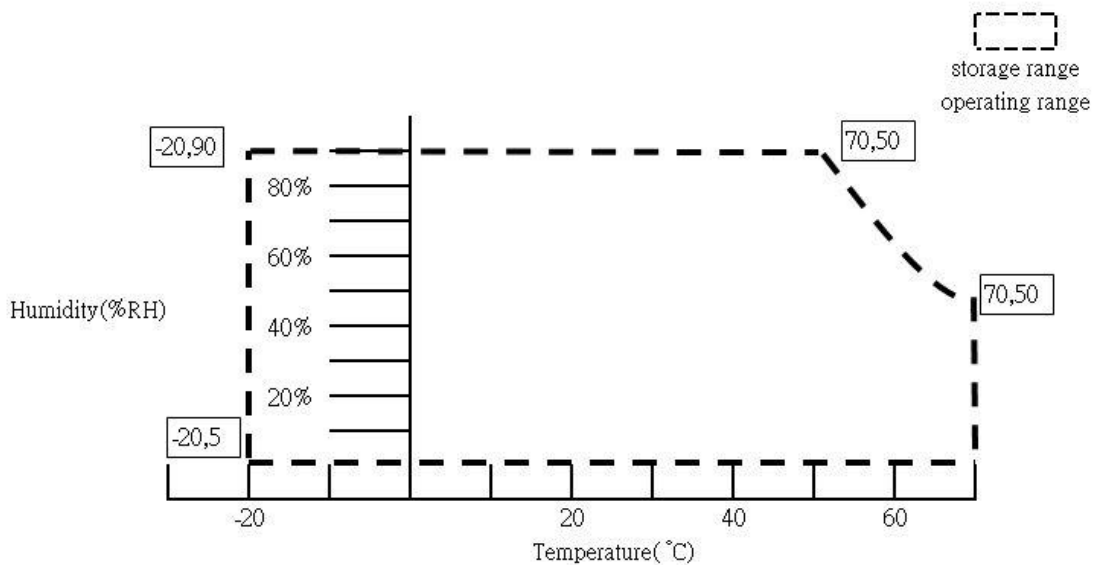

4. ELECTRICAL CHARACTERISTICS

(1).TFT-LCD

ITEM		SYMBOL	MIN	TYP	MAX	UNIT	NOTE
LCD Power Voltage		VCC	4.5	5.0	5.5	V	
LCD Power Current		ICC	-	290	500	mA	*1)
LCD Rush Current		VCC_Irus			3	A	*3)
Logic Input Voltage (LVDS: IN+,IN-)	Common Voltage	VCM	$\frac{ VID }{2}$	-	$2.4 \cdot \frac{ VID }{2}$	V	Logic Input Voltage (LVDS: +,IN-)
	Differential Input Voltage	VID	200	-	600	mV	
	Threshold Voltage (HIGH)	VTH	-	-	100	mV	
	Threshold Voltage (LOW)	VTL	-100	-	-	mV	
Logic Input Voltage	VIH	0.7*DVDD	-	DVDD	V		Logic Input Voltage
	VIL	GND	-	0.3*DVDD	V		
Power consumption		P		TBD	TBD	W	

【Note】

*1)TYP. specification : Gray-level test Pattern (TYP Freq. @5.0V)

MAX. specification : Black test Pattern (TYP Freq. @5.0V)



Gray-level Pattern

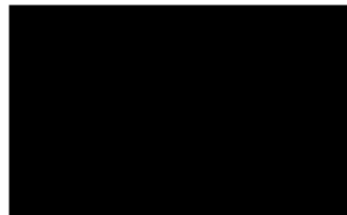

Black Pattern

*2) LVDS Signal Definite :

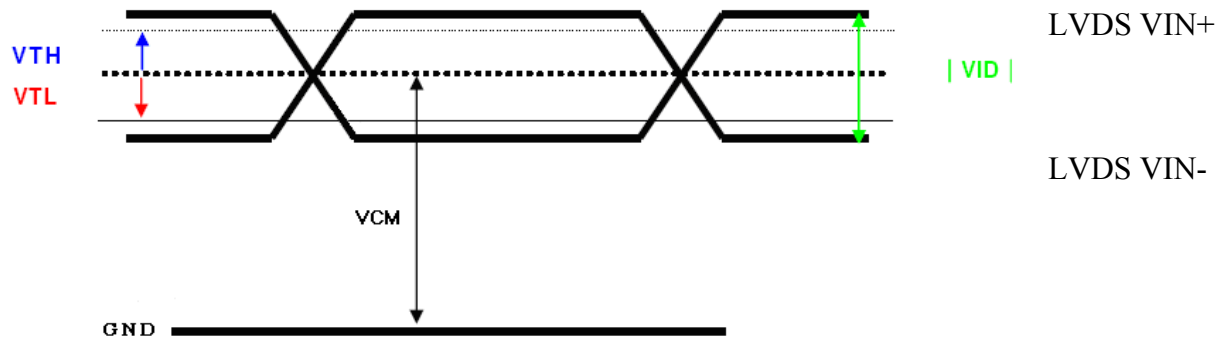

V_{IN+} : Positive differential DATA & CLK Input

V_{IN-} : Negative differential DATA & CLK Input

*3) Irush measure condition

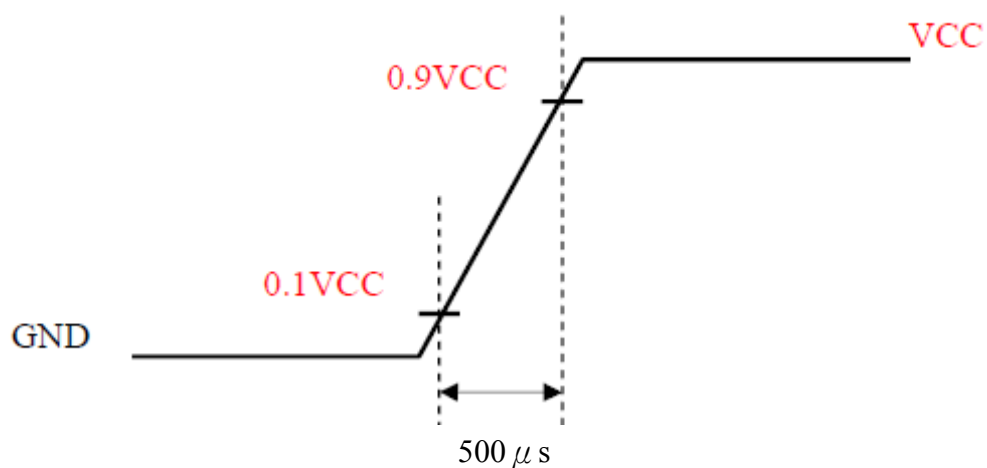
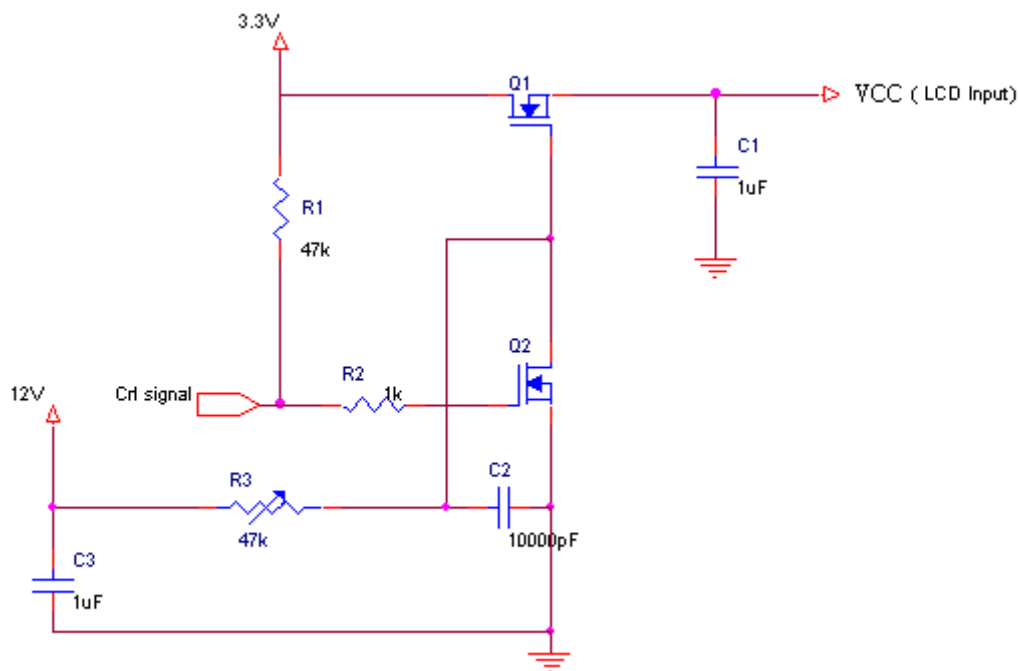

(2) Backlight

1. Electrical specification

1-1 single

LED $T_a=25^{\circ}\text{C}$ (T_a : ambient temperature)

Item	Symbol	Condition	Min	Typ	Max	Unit	Remarks
Forward Voltage	VF	$T_a=25^{\circ}\text{C}$ Each serial=110mA	2.8	3.1	3.4	V	1) 2) 3)
Forward Current	IF	$T_a=25^{\circ}\text{C}$ Each serial=110mA	--	110	--	mA	1) 2) 3)
Backlight Lifetime	-		--	50,000	--	Hr	4) 5)

Remarks :

*1)LED Circuit Diagram :



*2) A : Anode(+), K : Cathode(-)

*3) Definition of the LED life time: Luminance (L) under 50% of specification.

*4) When the ambient temperature T_a overstep 25°C , it will serious damage life time.

*5) When the LED operation current I_F overstep 110mA, it will serious damage life time.

(3).Converter Specification for Backlight

$T_a=25^{\circ}\text{C}$

ITEM	SYMBOL	MIN	TYP	MAX	UNIT	NOTE
LED Driver Input Voltage	VLED	10.8	12.0	13.2	V	
LED Driver Input Current	IVLED	-	1180	1600	mA	*1)
LED Rush Current	VLED_Irush			3	A	*3)
Dimming Control	High	2.4	--	5.5	V	Dimming Control
	Low	0		0.8		
PWM Frequency	LED_PWM	100	200	1K	Hz	*2)
Duty Ratio		5	-	100	%	
ON/OFF Control	High	2.4		5.5	V	ON/OFF Control
	Low	0		0.8		
Power Consumption (Backlight)	BLW	--	TBD	TBD	W	

- *1) Maximum LED Driver Input Current at 10.8V Input Voltage/PWM Duty 100%.
- *2) The ADJ adjust signal level is 0~3.3V , operation frequency:100Hz~1KHz ◦

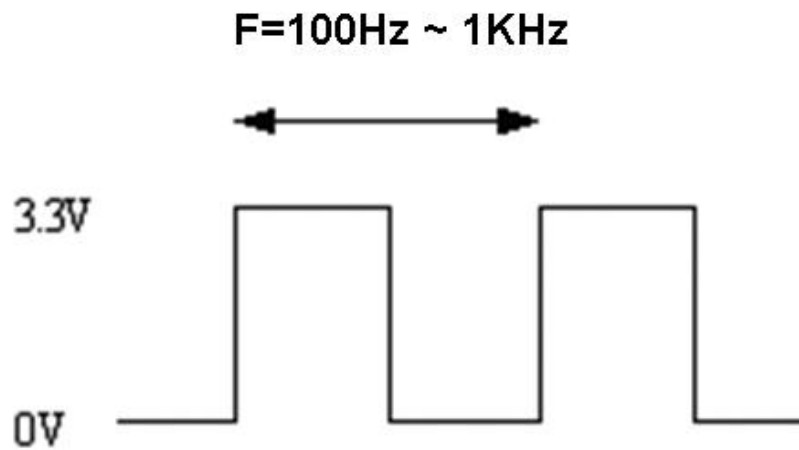

The ADJ can adjust LED BL brightness , where Duty and Luminance are in direct ratio.

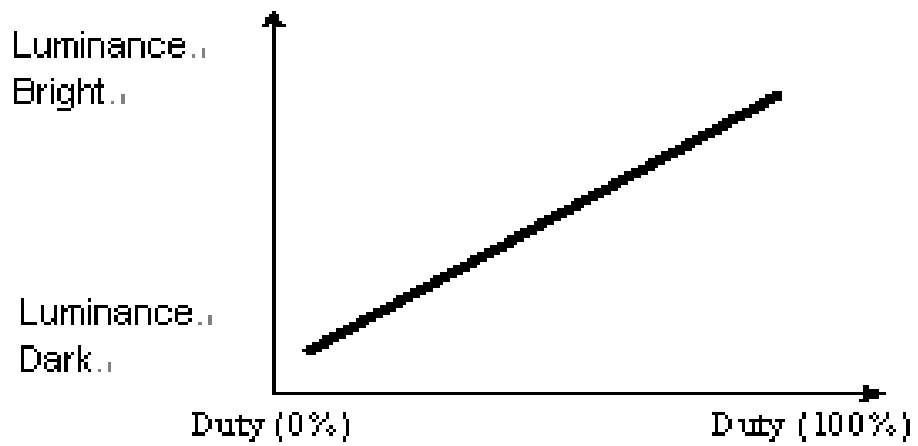

*3) Irush measure condition

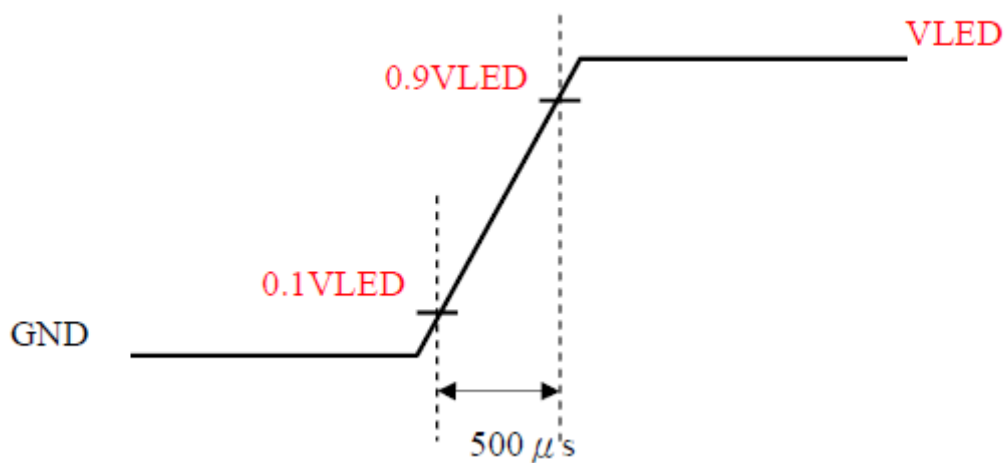
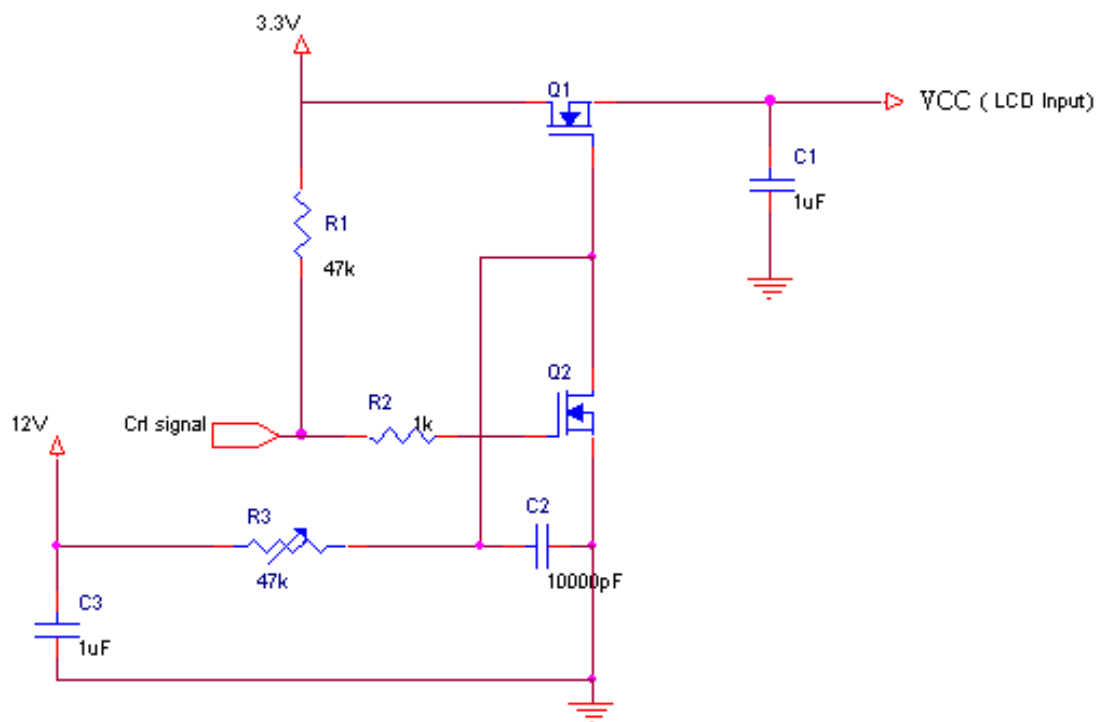

(4). Power and Signal sequence

Power Sequence :

$0.50 \text{ ms} \leq T1 \leq 10 \text{ ms}$	$200 \text{ ms} \leq T3$	$10 \text{ ms} \leq T8$
$0.01 \text{ ms} < T2 \leq 50 \text{ ms}$	$10 \text{ ms} \leq T5$	$200 \text{ ms} \leq T9$
$0.50 \text{ ms} \leq T4 \leq 10 \text{ ms}$	$10 \text{ ms} \leq T6$	$500 \text{ ms} \leq T11$
$0.01 \text{ ms} < T10 \leq 50 \text{ ms}$	$0 \text{ ms} \leq T7$	

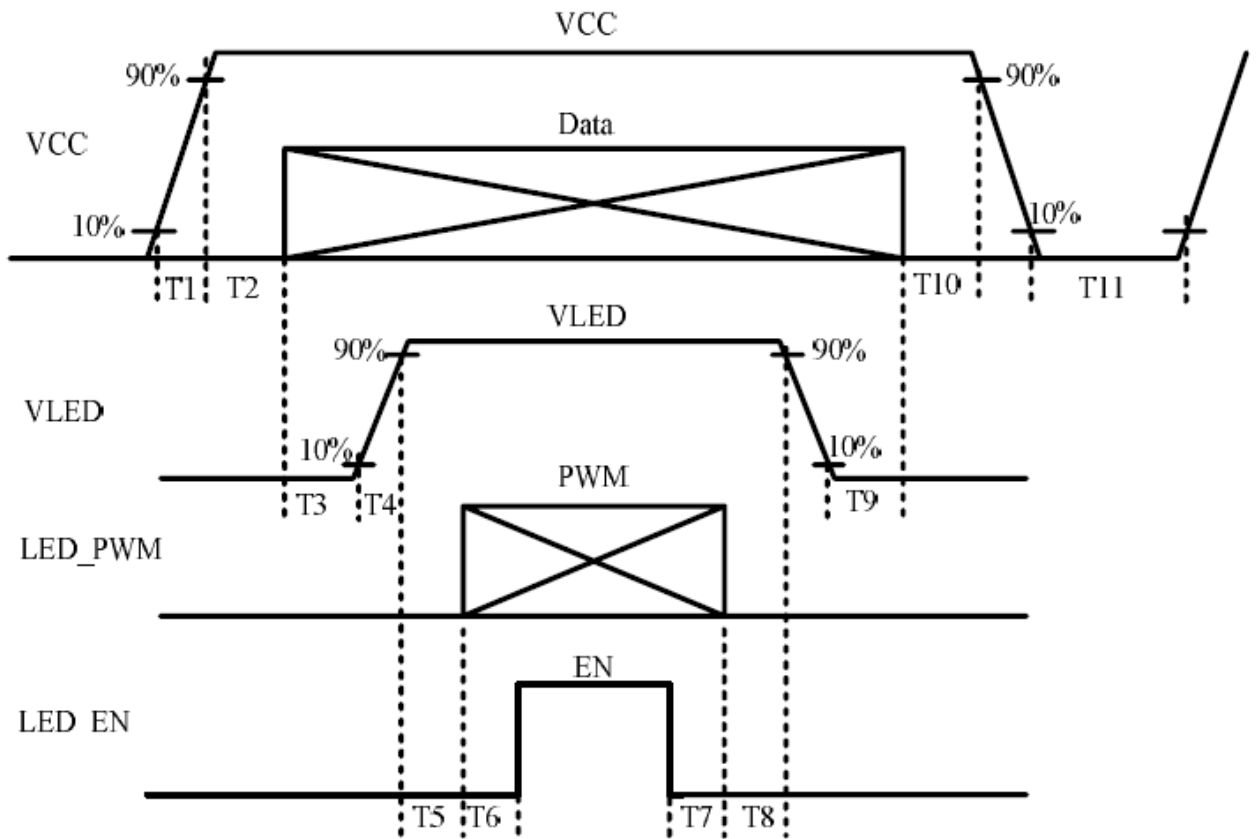

Data: NIND0 ~ NIND3 , PIND0 ~ PIND3 , NINC , PINC , DENA

5. INTERFACE PIN CONNECTION

Used connector: 093G30-B2001A-M4(STARCONN) or equivalent

PIN NO.	SYMOBL	FUNCTION
1	RXO0-	minus signal of odd channel 0(LVDS)
2	RXO0+	plus signal of odd channel 0(LVDS)
3	RXO1-	minus signal of odd channel 1(LVDS)
4	RXO1+	plus signal of odd channel 1(LVDS)
5	RXO2-	minus signal of odd channel 2(LVDS)
6	RXO2+	plus signal of odd channel 2(LVDS)
7	GND	ground
8	RXOC-	minus signal of odd clock channel (LVDS)
9	RXOC+	plus signal of odd clock channel (LVDS)
10	RXO3-	minus signal of odd channel 3(LVDS)
11	RXO3+	plus signal of odd channel 3(LVDS)
12	RXE0-	minus signal of even channel 0(LVDS)
13	RXE0+	plus signal of even channel 0(LVDS)
14	GND	ground
15	RXE1-	minus signal of even channel 1(LVDS)
16	RXE1+	plus signal of even channel 1(LVDS)
17	GND	ground
18	RXE2-	minus signal of even channel 2(LVDS)
19	RXE2+	plus signal of even channel 2(LVDS)
20	RXEC-	minus signal of even clock channel (LVDS)
21	RXEC+	plus signal of even clock channel (LVDS)
22	RXE3-	minus signal of even channel 3(LVDS)
23	RXE3+	plus signal of even channel 3(LVDS)
24	GND	ground
25	GND	ground
26	GND	ground
27	GND	ground
28	VCC	Power supply input voltage(5.0 V)
29	VCC	Power supply input voltage(5.0 V)
30	VCC	Power supply input voltage(5.0 V)

- 1) Please keep the NC Pin and don't connect it to GND or other signals.
- 2) GND Pin must connect to the ground, don't let it be a vacant pin.

(2) CN2 (Backlight)

Outlet connector : 7905Y10-000000-M1-R (STARCONN)

Plug connector : H790525-101000 (STARCONN) or equivalent

PIN #	SYMBOL	FUNCTION
1	VLED	+12V Power Supply
2	VLED	+12V Power Supply
3	VLED	+12V Power Supply
4	VLED	+12V Power Supply
5	GND	GND
6	GND	GND
7	GND	GND
8	GND	GND
9	LED_EN	ON : 5V / OFF: 0V (*1)
10	LED_PWM	Light Dimming Control : PWM Input for Dimming: L : 0V / H : 5V Freq : 100-1000Hz Duty : 5%-100%

*1) Enable High=5.5 to 2.4, Low=0 to 0.8V

6. INTERFACE TIMING

(1) Timing Specifications

		ITEM	SYMBOL	MIN	TYP	MAX	UNIT
LCD Timing	DCLK	Frequency	f_{CLK}	44	54	67.5	MHz
		Period	t_{CLK}	14.81	18.52	22.2	ns
	DATA Enable	Horizontal Active	t_{HA}		640		t_{CLK}
		Horizontal Blank	t_{HB}	140	204	-	t_{CLK}
		Horizontal Total Time	t_H	780	844	2047	t_{CLK}
		Vertical Active Time	t_{VA}		1024		tH
		Vertical Blank Time	t_{VB}	8	42	126	tH
		Vertical Total Time	t_V	1032	1066	1150	tH
DENA	Vertical Frame Rate	Fr	50	60	75	Hz	

(2) Timing Chart

a. Horizontal Timing

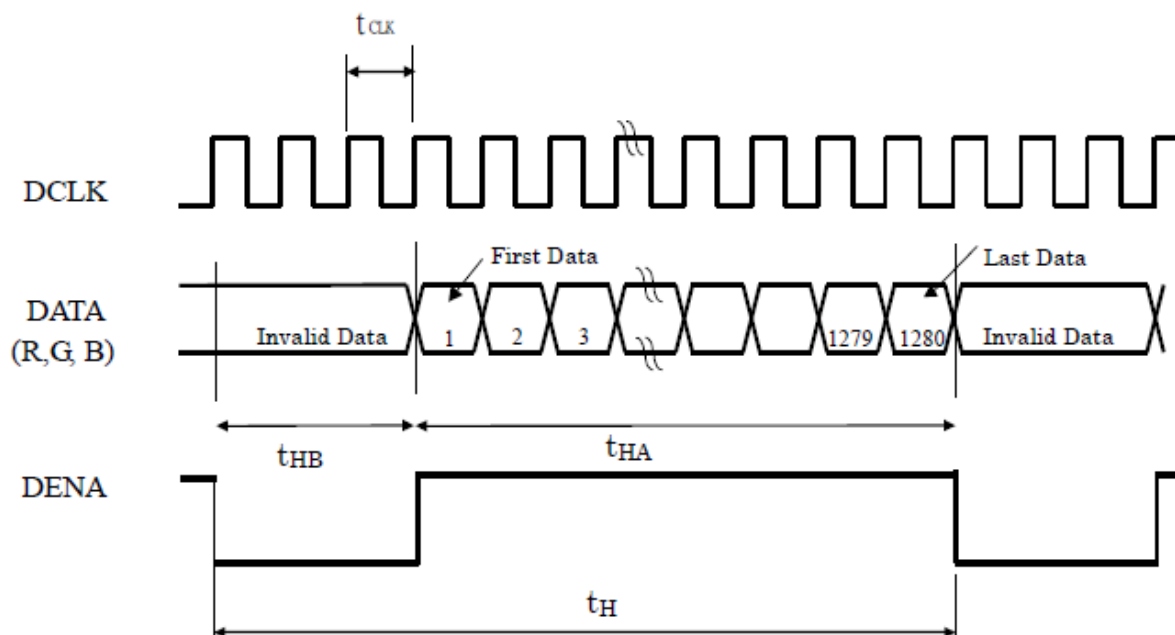

b. Vertical Timing

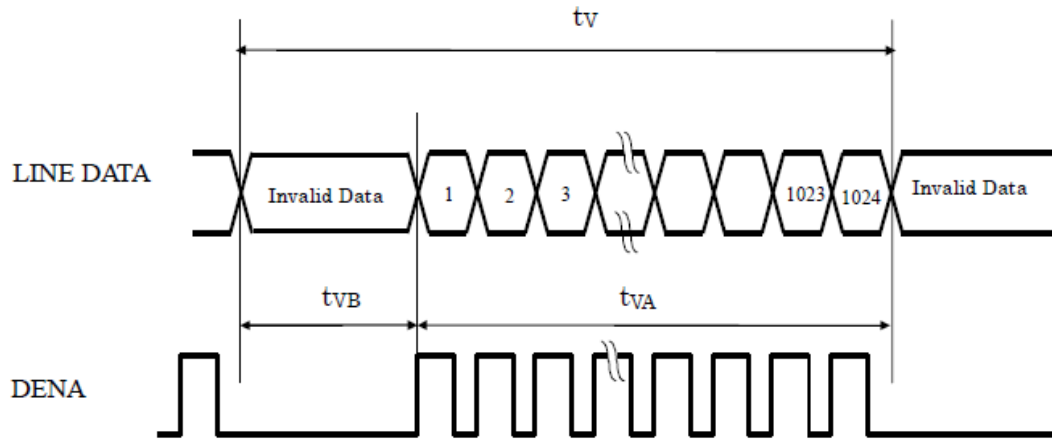

(3) LVDS DATA (VESA) : Timing Chart

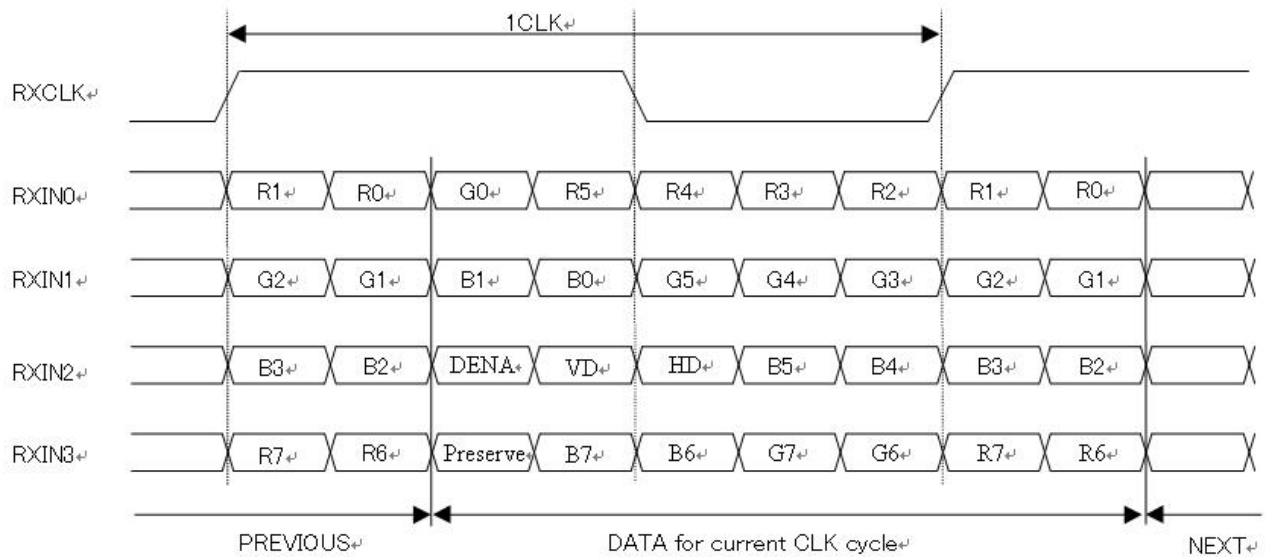

(4) Color Data Assignment

COLOR	INPUT DATA	R DATA								G DATA								B DATA							
		R7 MSB	R6	R5	R4	R3	R2	R1	R0 LSB	G7 MSB	G6	G5	G4	G3	G2	G1	G0 LSB	B7 MSB	B6	B5	B4	B3	B2	B1	B0 LSB
BASIC COLOR	BLACK	0	0	0	0	0	0	0	0	0	0	0	0	0	0	0	0	0	0	0	0	0	0	0	0
	RED(255)	1	1	1	1	1	1	1	1	0	0	0	0	0	0	0	0	0	0	0	0	0	0	0	
	GREEN(255)	0	0	0	0	0	0	0	0	1	1	1	1	1	1	1	0	0	0	0	0	0	0	0	
	BLUE(255)	0	0	0	0	0	0	0	0	0	0	0	0	0	0	0	1	1	1	1	1	1	1	1	
	CYAN	0	0	0	0	0	0	0	0	1	1	1	1	1	1	1	1	1	1	1	1	1	1	1	
	MAGENTA	1	1	1	1	1	1	1	1	0	0	0	0	0	0	0	1	1	1	1	1	1	1	1	
	YELLOW	1	1	1	1	1	1	1	1	1	1	1	1	1	1	1	0	0	0	0	0	0	0	0	
	WHITE	1	1	1	1	1	1	1	1	1	1	1	1	1	1	1	1	1	1	1	1	1	1	1	
RED	RED(0)	0	0	0	0	0	0	0	0	0	0	0	0	0	0	0	0	0	0	0	0	0	0		
	RED(1)	0	0	0	0	0	0	0	1	0	0	0	0	0	0	0	0	0	0	0	0	0	0		
	RED(2)	0	0	0	0	0	0	1	0	0	0	0	0	0	0	0	0	0	0	0	0	0	0		
	RED(254)	1	1	1	1	1	1	1	0	0	0	0	0	0	0	0	0	0	0	0	0	0	0		
	RED(255)	1	1	1	1	1	1	1	1	0	0	0	0	0	0	0	0	0	0	0	0	0	0		
GREEN	GREEN(0)	0	0	0	0	0	0	0	0	0	0	0	0	0	0	0	0	0	0	0	0	0	0		
	GREEN(1)	0	0	0	0	0	0	0	0	0	0	0	0	0	1	0	0	0	0	0	0	0	0		
	GREEN(2)	0	0	0	0	0	0	0	0	0	0	0	0	0	1	0	0	0	0	0	0	0	0		
	GREEN(254)	0	0	0	0	0	0	0	1	1	1	1	1	1	1	0	0	0	0	0	0	0	0		
	GREEN(255)	0	0	0	0	0	0	0	1	1	1	1	1	1	1	1	0	0	0	0	0	0	0		
BLUE	BLUE(0)	0	0	0	0	0	0	0	0	0	0	0	0	0	0	0	0	0	0	0	0	0	0		
	BLUE(1)	0	0	0	0	0	0	0	0	0	0	0	0	0	0	0	0	0	0	0	0	0	1		
	BLUE(2)	0	0	0	0	0	0	0	0	0	0	0	0	0	0	0	0	0	0	0	0	1	0		
	BLUE(254)	0	0	0	0	0	0	0	0	0	0	0	0	0	0	1	1	1	1	1	1	1	0		
	BLUE(255)	0	0	0	0	0	0	0	0	0	0	0	0	0	0	1	1	1	1	1	1	1	1		

[Note]

1) Definition of gray scale:

Color (n): n indicates gray scale level; higher n means brighter level.

2) Data: 1-High, 0-Low.

3) This assignment is applied to both odd and even data.

7. BLOCK DIAGRAM

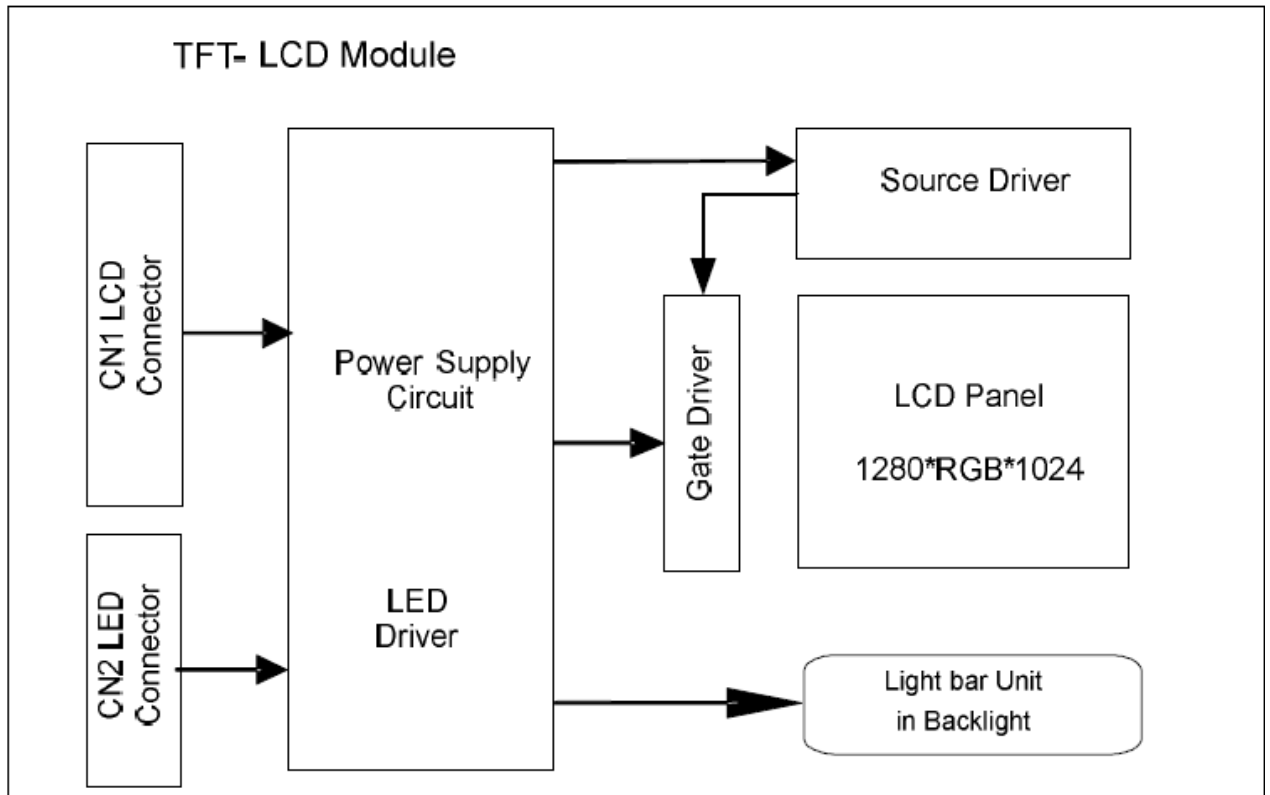

8. OPTICAL CHARACTERISTICS

Ta=25°C , VCC=3.3

ITEM		SYMBOL	CONDITION	min	typ	max	UNIT	REMARK
Contrast Ratio		CR	$\theta = \psi = 0^\circ$	--	700	--	--	*1) 2)
Luminance(CEN)		L	$\theta = \psi = 0^\circ$	360	450	--	cd/m ²	*1) 3)
9P Uniformity		ΔL	$\theta = \psi = 0^\circ$	75	80	--	%	*1) 3)
Response Time		Tr	$\theta = \psi = 0^\circ$	--	10	15	ms	*5)
		Tf	$\theta = \psi = 0^\circ$	--	15	25		
Crosstalk		CT	$\theta = \psi = 0^\circ$	--	--	--	%	*6)
Viewing Angle	Horizontal	ψ	$CR \geq 10$	-70~70	-80~80	--	Deg.	*4)
	Vertical	θ		-60~60	-70~70	--		
Color Coordinates		White	$\theta = \psi = 0^\circ$	(0.263) (0.279)	(0.313) (0.329)	(0.363) (0.379)		*3)
		Red		TBD	TBD	TBD		
		Green		TBD	TBD	TBD		
		Blue		TBD	TBD	TBD		
Gamut		CG	$\theta = \psi = 0^\circ$	67	72	--	--	--
Gamma		γ	VESA	2	2.2	2.4	--	*7)

[Note]

Definition of these measurement items is as follows:

1) Setup of Measurement Equipment

The LCD module should be turn-on to a stable luminance level to be reached. The measurement should be executed after lighting Backlight for 20 minutes and in a dark room.

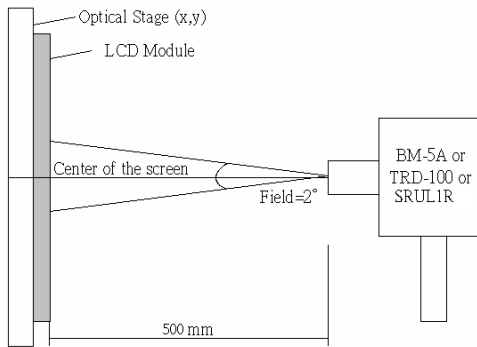

2).Definition of Contrast Ratio:

CR=ON (White) Luminance/OFF (Black) Luminance

3).Definition of Luminance and Luminance uniformity:

Center Luminance, &Color coordinate: measuring the luminance of the point no. 5

Average Luminance: measuring average luminance of points no.1-no.9

Uniformity: $\Delta L = [L (\text{Min})/L (\text{Max})] \times 100 \%$

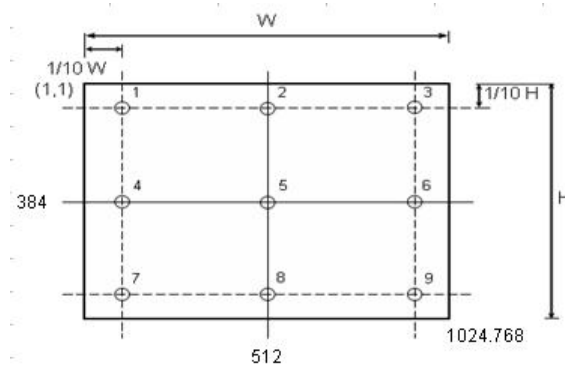

4).Definition of Viewing Angle (θ , ψ):

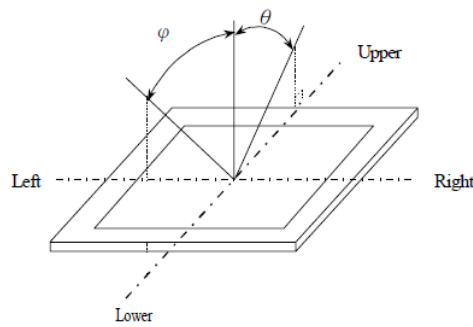

5) Definition of Response Time:

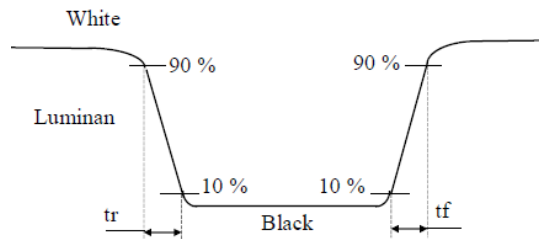

6) Definition of crosstalk:

$$CT = |Y_B - Y_A| / Y_A \times 100 (\%)$$

Y_A : The luminance of measured position at pattern A

Y_B : The luminance of measured position at pattern B with Gray level 0

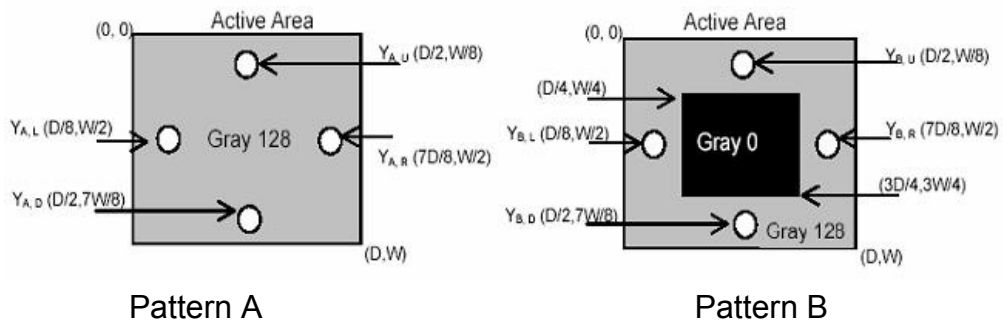

7) Definition of Gamma (γ), follow VESA standard sampling every 16 gray level

(0,16,32,.....224,240,255)

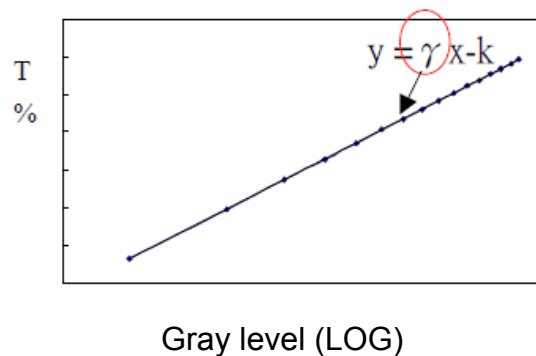

9. RELIABILITY TEST CONDITIONS

(1) Temperature and Humidity

TEST ITEMS	CONDITIONS	REMARK
High Temperature High Humidity Operation	70°C; 90%RH; 240hrs (No condensation)	
High Temperature Operation	70°C; 240hrs	
High Temperature Storage	80°C; 240hrs	
Low Temperature Operation	-20°C; 240hrs	
Low Temperature Storage	-30°C; 240hrs	
Thermal Shock	Between -30°C(1hr) ~ 80°C(1hr); 100 Cycles	
Image Sticking	25 °C ± 2 °C ; 4hrs	Note 1
MTBF	Life assurance 20,000hrs	

[Note]

Definition of these measurement items is as follows:

1) Image Sticking :

Condition of image sticking test: 25°C

Operation with test pattern sustained for 4hrs, then change to gray pattern immediately.

After 5 min, the Mura must be disappeared completely.

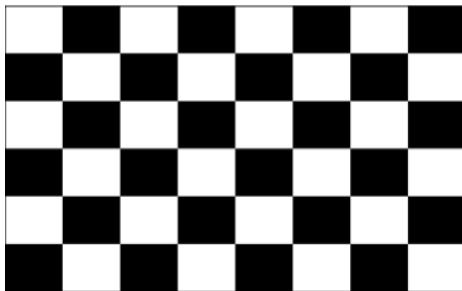

(a) Test Pattern(Chess Board Pattern)



(b) judgment Pattern(Mid-Gray Pattern)

(2) Shock & Vibration

ITEMS	CONDITIONS
SHOCK (NON-OPERATION)	Shock level: 1470 m/s ² (150 G) Waveform: half sinusoidal wave, 2ms Number of shocks: one shock each direction
VIBRATION (NON-OPERATION)	Sweep:1G, 10~300Hz Vibration : sinusoidal wave, 30min /axis

(3) ESD

POSITION	CONDITION(MDL turn off)
Connector	1. 200 pF , 0 Ω , ±250 V 2. contact mode for each pin
Module	1. 150 pF , 330 Ω , ±15K V (Air mode) , ±8K V (Contact mode) 2. Air mode, test 25 times for each test point 3. Contact mode, 25 times for each test point

(4) Judgment standard

The judgment of the above test should be made as follow: Pass: Normal display image with no line defect.

Fail: No display image or line defects

10. OUTLINE DIMENSION

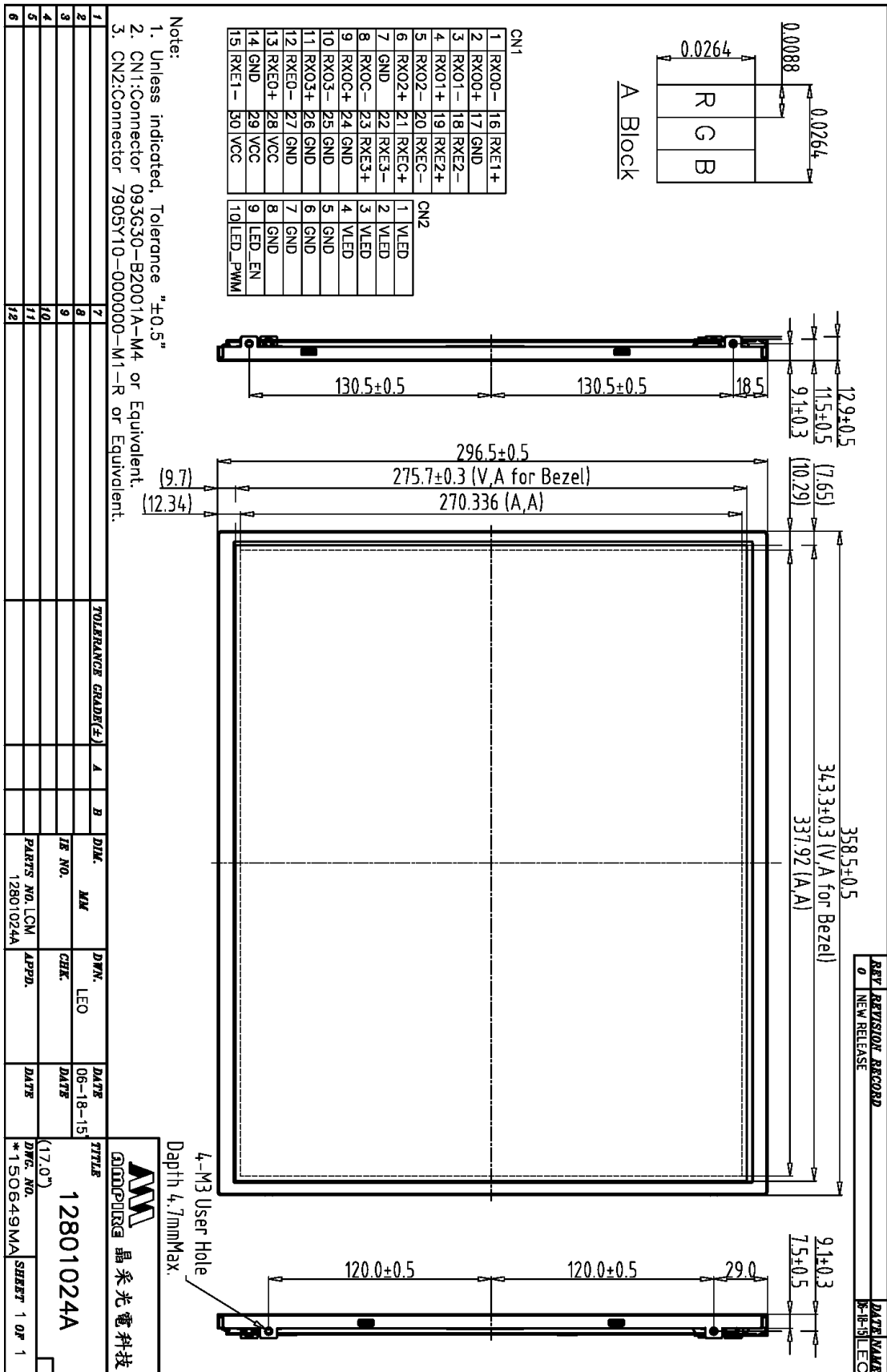

REV	REVISION RECORD	DATE NAME
0	NEW RELEASE	8-18-15 LEO

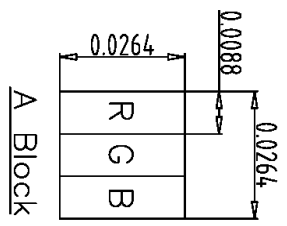

CN1		CN2	
1	RX00-	16	RXE1+
2	RX00+	17	GND
3	RX01-	18	RXE2-
4	RX01+	19	RXE2+
5	RX02-	20	RXE3-
6	RX02+	21	RXE3+
7	GND	22	RXE3-
8	RX03-	23	RXE3+
9	RX03+	24	GND
10	RX03-	25	GND
11	RX03+	26	GND
12	RXE0-	27	GND
13	RXE0+	28	VCC
14	GND	29	VCC
15	RXE1-	30	VCC

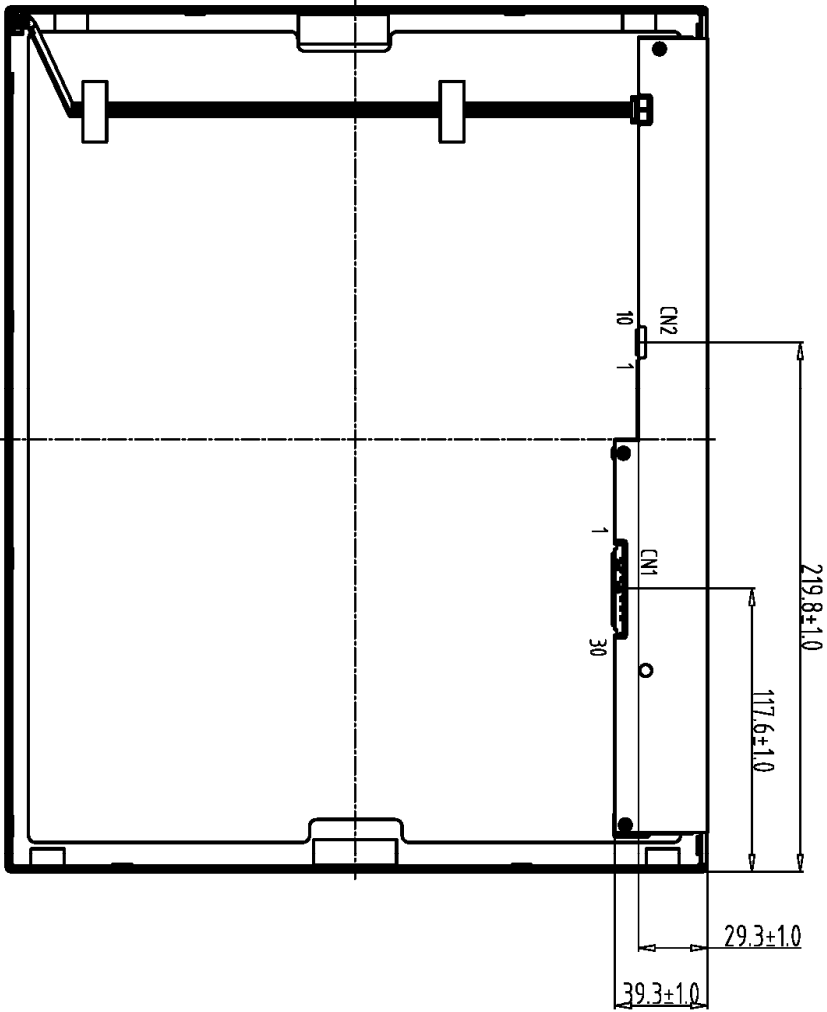

Back view

- Note:
- Unless indicated, Tolerance "±0.5"
 - CN1:Connector 093G30-B2001A-M4 or Equivalent.
 - CN2:Connector 7905Y10-000000-M1-R or Equivalent.

1		7		TOLERANCE GRADIENT		A	B	DIM.	MM	DWN.	LEO	DATE	DATE	STYLE	DATE	DWG. NO.	SHEET
2		8										06-18-15		AMPIRE		12801024A	1 OF 1
3		9						IS NO.		CHEK.		DATE		晶采光電科技			
4		10						PARTS NO.	12801024A	APPD.		DATE					
5		11										DATE					
6		12										DATE					