



晶采光電科技股份有限公司  
AMPIRE CO., LTD.

# SPECIFICATIONS FOR LCD MODULE

<b>CUSTOMER</b>	
<b>CUSTOMER PART NO.</b>	
<b>AMPIRE PART NO.</b>	<b>AM-640480G2TNQW-00H</b>
<b>APPROVED BY</b>	
<b>DATE</b>	

- Approved For Specifications  
 Approved For Specifications & Sample

**AMPIRE CO., LTD.**  
**Building A., 4F., No.116, Sec. 1, Sintai 5th Rd., Xizhi Dist,**  
**New Taipei City 221, Taiwan (R.O.C.)**  
**新北市汐止區新台五路一段 116 號 4 樓(東方科學園區 A 棟)**  
**TEL:886-2-26967269 , FAX:886-2-26967196 or 26967270**

APPROVED BY	CHECKED BY	ORGANIZED BY

## RECORD OF REVISION

Revision Date	Page	Contents	Editor
2008/6/16	--	New Release	Sunglin
2008/9/8	3	Correct the physical specification	Sunglin
2009/3/17	7	Correct LED PWM Frequency	JOHN
2010/1/15	3	Improved inner FPC material to better reliability	Eric
2014/3/3	4	Update LED life time to 30000hr	Patrick

## 1. INTRODUCTION

This is a color active matrix TFT-LCD that uses amorphous silicon TFT as a switching device. This model is composed of a 5.7inch TFT-LCD panel, touch panel, a driving circuit and LED backlight system. This TFT-LCD has a high resolution (640(R.G.B) X 480) and can display up to 262,144 colors.

### 1-1. Features

- VGA Resolution
- 6 Bits color driver with 1 channel TTL interface
- Wide range operation temperature
- Improved inner FPC material to better reliability.

## 2. PHYSICAL SPECIFICATIONS

Item	Specifications	unit
Display resolution(dot)	640RGB (W) x 480(H)	dots
Display area	115.2 (W) x 86.4 (H)	mm
Pixel pitch	0.18 (W) x 0.18 (H)	mm
Color configuration	R.G.B Vertical stripe	
Overall dimension	127.0(W)x98.43(H)x6.6(D)---(Typ)	mm
Surface treatment	Antiglare	
Brightness	500	cd/m <sup>2</sup>
Contrast ratio	250 : 1	
Backlight unit	LED	
Display color	262,144	colors
Viewing Direction	12 o'clock (Gray Inversion)	
Display Mode	Normally White	

## 3. ABSOLUTE MAXIMUM RATINGS

ITEM	SYMBOL	MIN	MAX	UNIT	NOTE
Power Supply Voltage	Vcc	-0.5	5	V	
Signal Input Voltage	DCLK , DE, RGB	-0.5	Vcc + 0.5	V	
Operation Temperature	Top	-20	70	°C	(1)
Storage Temperature	Tstg	-30	80	°C	(1)

## 4. ELECTRICAL CHARACTERISTICS

### 4-1 TFT LCD Module voltage

ITEM	SYMBOL	MIN	TYP	MAX	UNIT	NOTE
Power Voltage For LCD	V <sub>CC</sub>	3.0	3.3	3.6	V	(1)
Power Voltage For VLED	VLED	--	5.0	--	V	
Logic Input Voltage	V <sub>IH</sub>	V <sub>CC</sub> *0.7	--	V <sub>CC</sub>	V	
	V <sub>IL</sub>	0	--	V <sub>CC</sub> *0.3	V	
ADJ Input Voltage	V <sub>IH</sub>	3.0	--	5.0	V	
	V <sub>IL</sub>	GND	--	0.3	V	

\* LED Life Time : MTBF 30,000 hours. (Ta=25°C)

### 4-2 TFT LCD current consumption

ITEM	SYMBOL	MIN	TYP	MAX	UNIT	NOTE
LCD Power Current	I <sub>CC</sub>	-	82	-	mA	(1)
LED Power Current	I <sub>LED</sub> (VLED=5V)	-	290	-	mA	(2)

NOTE : (1) Typ : under 64 gray pattern Max : under black pattern



(a) 64 Gray Pattern

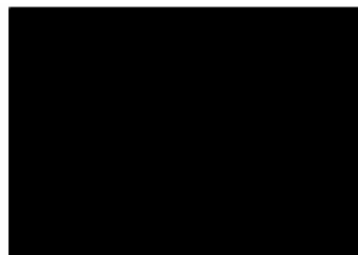

(b) Black Pattern

(2) Typ : When V<sub>LED</sub> is 5.0V Max : When V<sub>LED</sub> is 4.5V

One LED Dice :

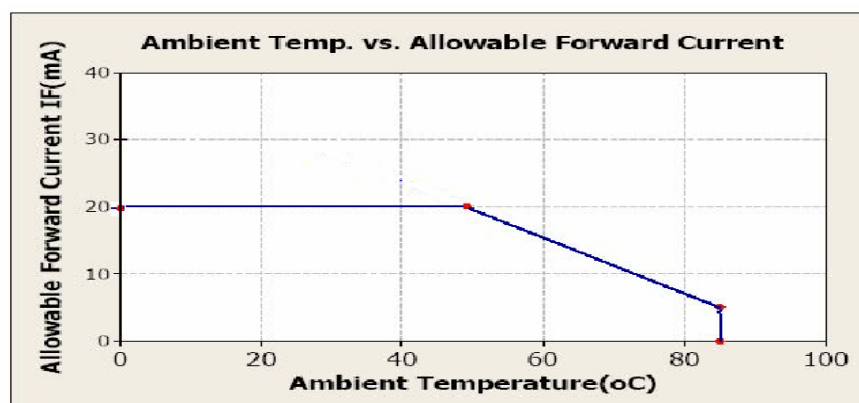

## 6. INTERFACE

Pin No	Symbol	Function
1	U/D	Up or Down Display Control
2	(NC)	No connection
3	Hsync(NC)	Horizontal SYNC. (Sync mode used)
4	VLED	Power Supply for LED
5	VLED	Power Supply for LED
6	VLED	Power Supply for LED
7	Vcc	Power Supply for LCD
8	Vsync(NC)	Vertical SYNC. (Sync mode used)
9	DE	Data Enable
10	Vss	Power Ground
11	Vss	Power Ground
12	ADJ	Adjust for LED Brightness
13	B5	Blue Data 5 (MSB)
14	B4	Blue Data 4
15	B3	Blue Data 3
16	Vss	Power Ground
17	B2	Blue Data 2
18	B1	Blue Data 1
19	B0	Blue Data 0 (LSB)
20	Vss	Power Ground
21	G5	Green Data 5 (MSB)
22	G4	Green Data 4
23	G3	Green Data 3
24	Vss	Power Ground
25	G2	Green Data 2
26	G1	Green Data 1
27	G0	Green Data 0 (LSB)
28	Vss	Power Ground
29	R5	Red Data 5 (MSB)
30	R4	Red Data 4
31	R3	Red Data 3
32	Vss	Power Ground
33	R2	Red Data 2
34	R1	Red Data 1
35	R0	Red Data 0 (LSB)
36	Vss	Power Ground
37	Vss	Power Ground
38	DCLK	Clock Signals
39	Vss	Power Ground
40	L/R	Left or Right Display Control

NOTE :

1. ADJ adjust brightness to control Pin , Pulse duty the bigger the brighter.

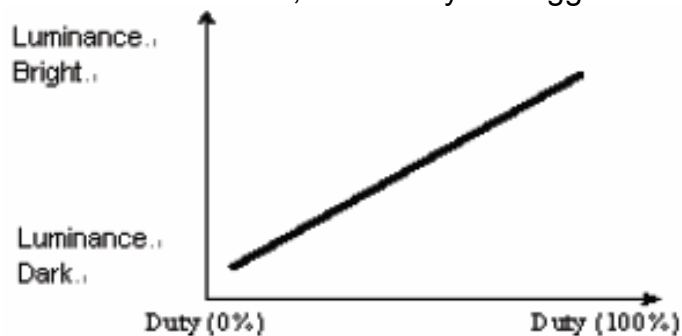

2. ADJ signal = 0 ~ 5.0V , operation frequency : 300Hz~1KHz

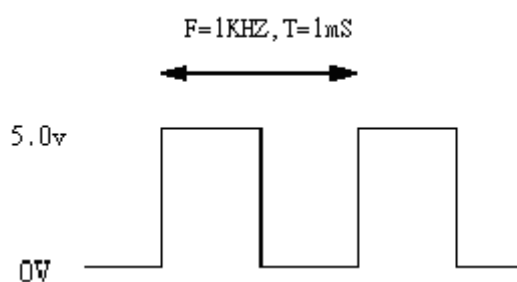

3. VSS Pin must ground contact , can not be floating.

4. U/D and L/R are controlled function

L/R	U/D	Function
1	0	Normally display
0	0	Left and Right opposite
1	1	Up and Down opposite
0	1	Left and Right opposite , Up and Down opposite

## 7. INPUT SIGNAL :

### 7-1 Timing Specification.

PARAMETER	Symbol	Min.	Typ.	Max	Unit
CLK frequency	$F_{CPH}$		25.175		MHz
CLK period	$T_{CPH}$	-	39.7	-	ns
CLK pulse duty	$T_{CWH}$	40	50	60	%
HS period	$T_H$	-	800	-	$T_{CPH}$
HS pulse width	$T_{WH}$	5	30	-	$T_{CPH}$
HS-first horizontal data time	$T_{HS}$	112	144	175	$T_{CPH}$
DEN pulse width	$T_{EP}$	-	640	-	$T_{CPH}$
VS pulse width	$T_{WV}$	1	3	5	$T_H$
VS-DEN time	$T_{STV}$	-	35	-	$T_H$
VS period	$T_V$	-	525	-	$T_H$

**Note:** When SYNC mode is used, 1st data start from 144th CLK after HS falling (when  $STHD[5:0]=00000$ )

PARAMETER	Symbol	Min.	Typ.	Max	Unit
OEV pulse width	$T_{OEV}$		100	-	$T_{CPH}$
CKV pulse width	$T_{CKV}$	-	96	-	$T_{CPH}$
HS-CKV time	$T_1$	-	52	-	$T_{CPH}$
HS-OEV time	$T_2$	-	8	-	$T_{CPH}$
HS-POL time	$T_3$	-	72	-	$T_{CPH}$
STV setup time	$T_{SUV}$	-	46	-	$T_{CPH}$
STV pulse width	$T_{WSTV}$	-	1	-	$T_H$

## 7-2 Timing chart

### Clock and Data input waveforms

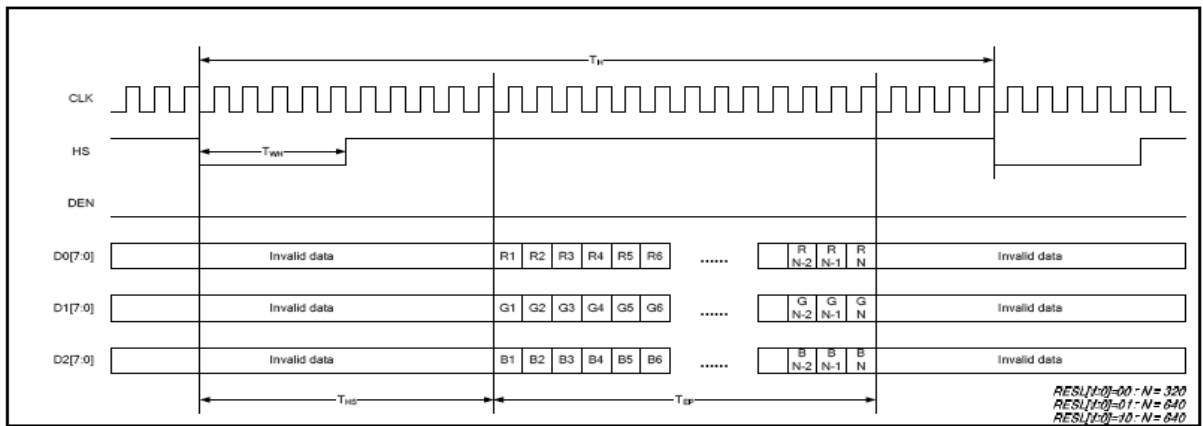
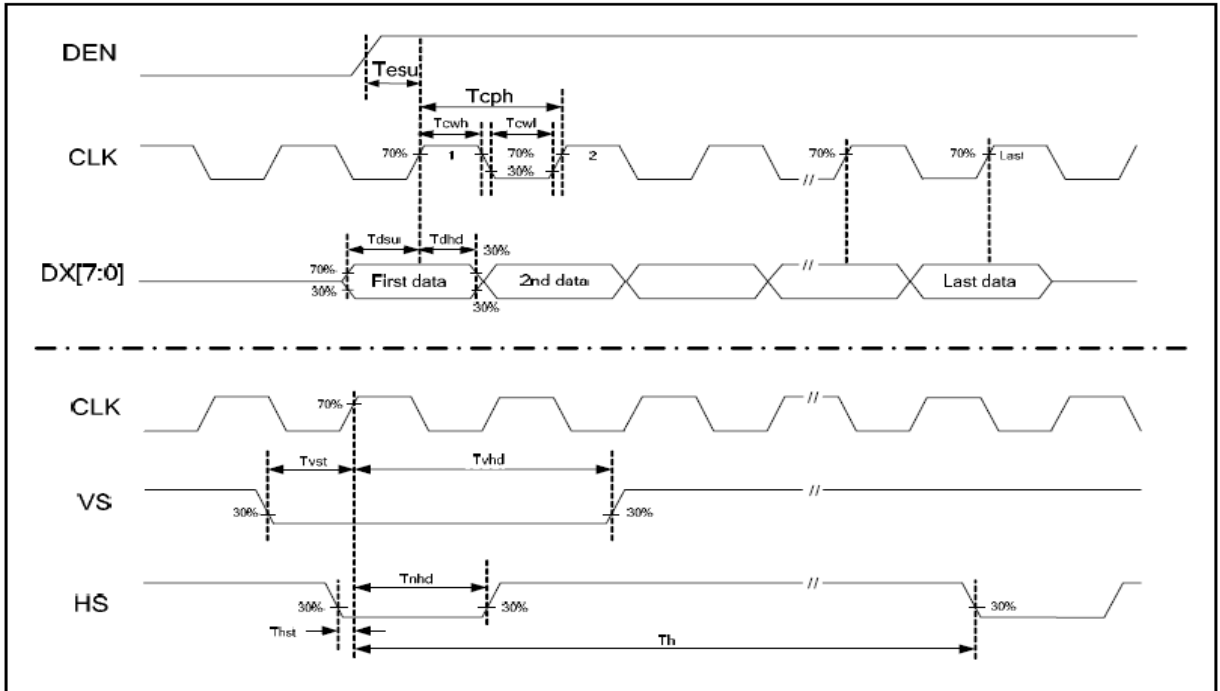

Parallel RGB SYNC Mode Horizontal Data Format

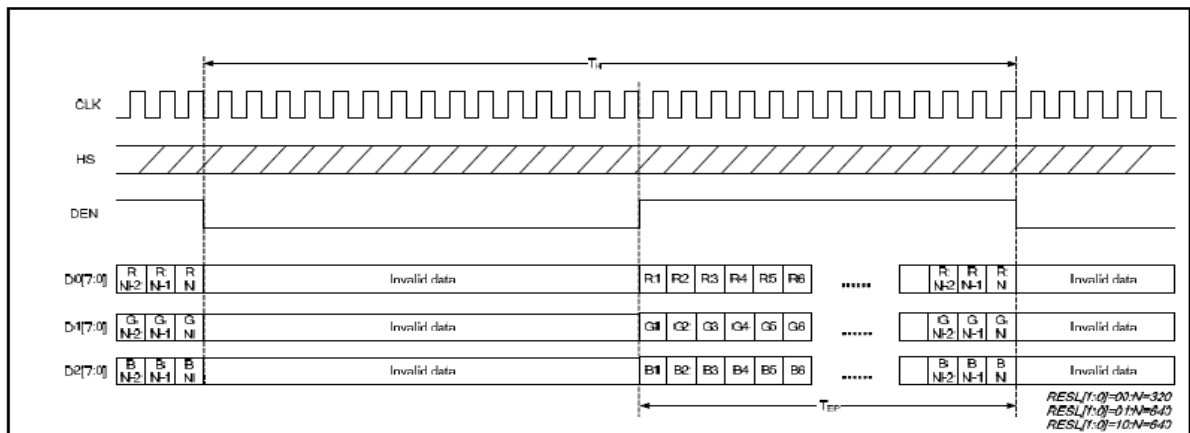

Parallel RGB DE Mode Horizontal Data Format



### 7-3 Color Data Assignment

COLOR	Input Data	R DATA						G DATA						B DATA					
		R5 MSB	R4	R3	R2	R1	R0 LSB	G5 MSB	G4	G3	G2	G1	G0 LSB	B5 MSB	B4	B3	B2	B1	B0 LSB
BASIC COLOR	BLACK	0	0	0	0	0	0	0	0	0	0	0	0	0	0	0	0	0	0
	RED(63)	1	1	1	1	1	1	0	0	0	0	0	0	0	0	0	0	0	0
	GREEN(63)	0	0	0	0	0	0	1	1	1	1	1	1	0	0	0	0	0	0
	BLUE(63)	0	0	0	0	0	0	0	0	0	0	0	0	1	1	1	1	1	1
	CYAN	0	0	0	0	0	0	1	1	1	1	1	1	1	1	1	1	1	1
	MAGENTA	1	1	1	1	1	1	0	0	0	0	0	0	1	1	1	1	1	1
	YELLOW	1	1	1	1	1	1	1	1	1	1	1	1	0	0	0	0	0	0
	WHITE	1	1	1	1	1	1	1	1	1	1	1	1	1	1	1	1	1	1
RED	RED(0)	0	0	0	0	0	0	0	0	0	0	0	0	0	0	0	0	0	0
	RED(1)	0	0	0	0	0	1	0	0	0	0	0	0	0	0	0	0	0	0
	RED(2)	0	0	0	0	1	0	0	0	0	0	0	0	0	0	0	0	0	0
	RED(62)	1	1	1	1	1	0	0	0	0	0	0	0	0	0	0	0	0	0
	RED(63)	1	1	1	1	1	1	0	0	0	0	0	0	0	0	0	0	0	0
GREEN	GREEN (0)	0	0	0	0	0	0	0	0	0	0	0	0	0	0	0	0	0	0
	GREEN (1)	0	0	0	0	0	0	0	0	0	0	0	1	0	0	0	0	0	0
	GREEN (2)	0	0	0	0	0	0	0	0	0	0	1	0	0	0	0	0	0	0
	GREEN (62)	0	0	0	0	0	0	1	1	1	1	1	0	0	0	0	0	0	0
	GREEN (63)	0	0	0	0	0	0	1	1	1	1	1	1	0	0	0	0	0	0
BLUE	BLUE (0)	0	0	0	0	0	0	0	0	0	0	0	0	0	0	0	0	0	0
	BLUE (1)	0	0	0	0	0	0	0	0	0	0	0	0	0	0	0	0	0	1
	BLUE (2)	0	0	0	0	0	0	0	0	0	0	0	0	0	0	0	0	1	0
	BLUE (62)	0	0	0	0	0	0	0	0	0	0	0	0	0	0	0	0	0	1
	BLUE (63)	0	0	0	0	0	0	0	0	0	0	0	0	0	0	0	0	1	0

NOTE : (1) Definition of Gray Scale , Color(n) : n is series of Gray Scale  
The more n value is the bright Gray Scale  
(2) Data : 1-High , 0-Low

## 8. OPTICAL CHARACTERISTICS

Item	Symbol	Condition	Min.	Typ.	Max.	Unit	Note	
Contrast ratio	CR	Point - 5 $\Theta = \Phi = 0^\circ$	200	250	--	--	(1)(2)(3)	
Luminance	Lw		--	500	-	cd/m <sup>2</sup>	(1)(3)	
Luminance Uniformity	$\Delta L$		70	75	-	%	(1)(3)	
Response Time ( White – Black )	$T_r + T_f$		--	50	--	ms	(1)(3)(5)	
Viewing Angle	Vertical	$\Theta$	CR $\geq$ 10 Point – 5	80	100	-	Deg.	(1)(2)(4)
	Horizontal	$\Phi$		120	140	-		
Color chromaticity	Red	Rx	Point - 5 $\Theta = \Phi = 0^\circ$	0.566	0.616	0.666	--	(1)(3)
		Ry		0.302	0.352	0.402		
	Green	Gx		0.308	0.358	0.408		
		Gy		0.518	0.568	0.618		
	Blue	Bx		0.096	0.146	0.196		
		By		0.086	0.136	0.186		
	White	Wx		0.296	0.346	0.396		
		Wy		0.328	0.378	0.428		

NOTE :

- (1) Measure conditions : 25°C ± 2°C , 60 ± 10%RH under 10Lux , in the dark room by BM-7TOPCON), viewing 2° , VCC=3.3V , VDD=3.3V

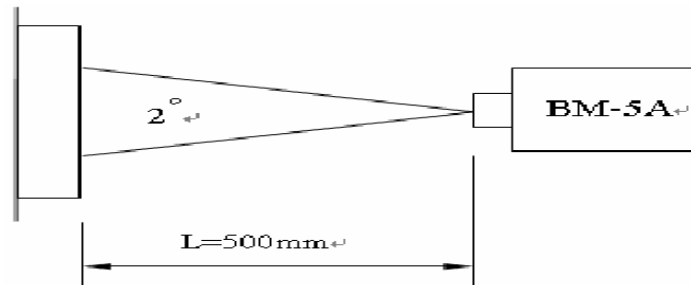

- (2) Definition of Contrast Ratio :

$$\text{Contrast Ratio (CR)} = (\text{White}) \text{ Luminance of ON} \div (\text{Black}) \text{ Luminance of OFF}$$

- (3) Definition of Luminance :

Definition of Luminance Uniformity

Measure white luminance on the point 5 as figure9-1

Measure white luminance on the point 1 ~ 9 as figure9-1

$$\Delta L = [ L(\text{MIN}) / L(\text{MAX}) ] \times 100\%$$

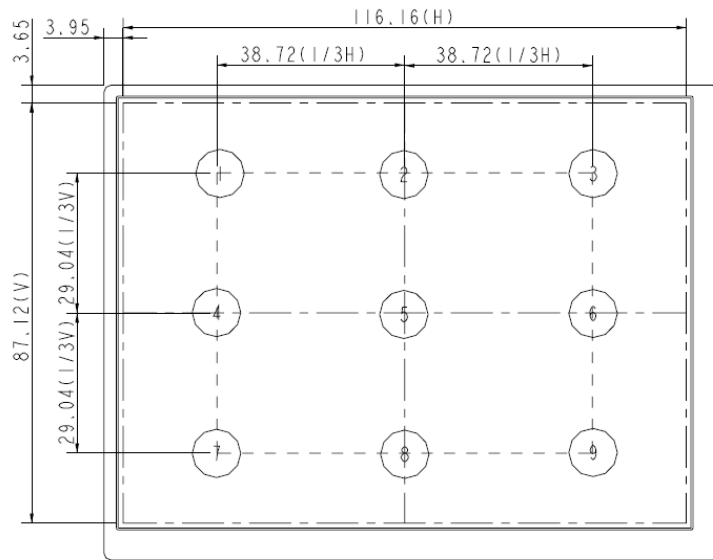

Fig9-1 Measuring point

(4) Definition of Viewing Angle( $\Theta, \Phi$ ), refer to Fig9-2 as below :

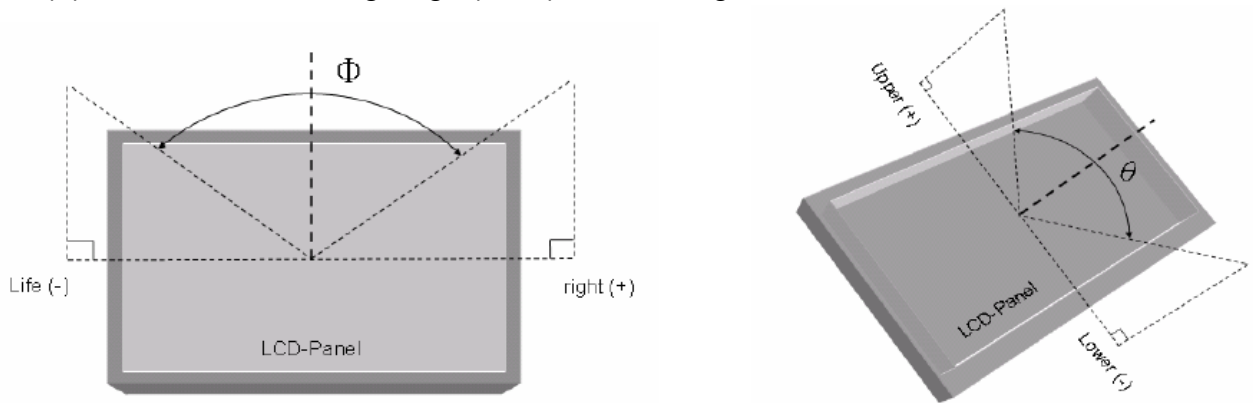

Fig9-2 Definition of Viewing Angle

(5) Definition of Response Time.(White – Black)

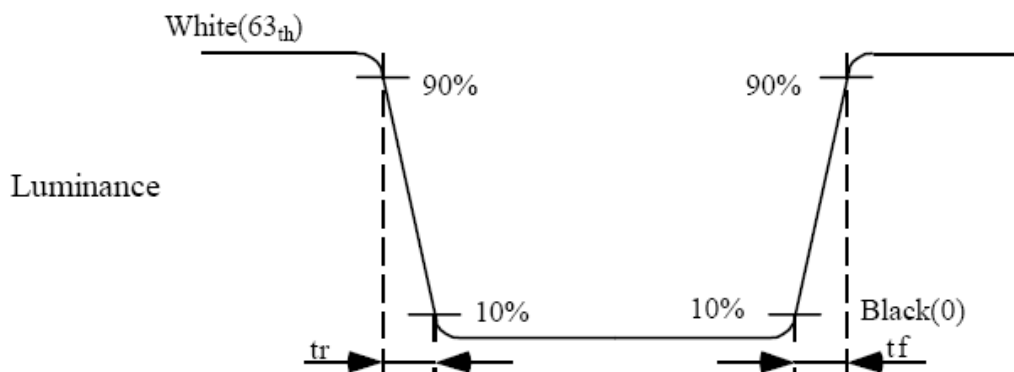

Fig9-3 Definition of Response Time(White-Black)

## 9. RELIABILITY TEST CONDITIONS

Test Item	Test Conditions	Note
High Temperature Operation	70±3°C , Dry t=240 hrs	
Low Temperature Operation	-20±3°C , Dry t=240 hrs	
High Temperature Storage	80±3°C , Dry t=240 hrs	1,2
Low Temperature Storage	-30±3°C , Dry t=240 hrs	1,2
Storage at High Temperature and Humidity	60°C, 90% RH , 240 hrs	1,2
Thermal Shock Test	-20°C (30min) ~ 70°C (30min) 100 cycles	1,2
Vibration Test (Packing)	Sweep frequency : 10 ~ 55 ~ 10 Hz/1min Amplitude : 0.75mm Test direction : X.Y.Z/3 axis Duration : 30min/each axis	2

Note 1 : Condensation of water is not permitted on the module.

Note 2 : The module should be inspected after 1 hour storage in normal conditions (15-35°C , 45-65%RH).

## 10. General Precautions

### 10-1 Safety

Liquid crystal is poisonous. Do not put it your month. If liquid crystal touches your skin or clothes, wash it off immediately by using soap and water.

### 10-2 Handling

1. The LCD panel is plate glass. Do not subject the panel to mechanical shock or to excessive force on its surface.
2. The polarizer attached to the display is easily damaged. Please handle it carefully to avoid scratch or other damages.
3. To avoid contamination on the display surface, do not touch the module surface with bare hands.
4. Keep a space so that the LCD panels do not touch other components.
5. Put cover board such as acrylic board on the surface of LCD panel to protect panel from damages.
6. Transparent electrodes may be disconnected if you use the LCD panel under environmental conditions where the condensation of dew occurs.
7. Do not leave module in direct sunlight to avoid malfunction of the ICs.

### 10-3 Static Electricity

1. Be sure to ground module before turning on power or operation module.
2. Do not apply voltage which exceeds the absolute maximum rating value.

### 10-4 Storage

1. Store the module in a dark room where must keep at  $+25\pm 10^{\circ}\text{C}$  and 65%RH or less.
2. Do not store the module in surroundings containing organic solvent or corrosive gas.
3. Store the module in an anti-electrostatic container or bag.

### 10-5 Cleaning

1. Do not wipe the polarizer with dry cloth. It might cause scratch.
2. Only use a soft sloth with IPA to wipe the polarizer, other chemicals might permanent damage to the polarizer.

### 10-5 Others

1. Do not keep the LCD at the same display pattern continually. The residual image will happen and it will damage the LCD. Please use screen saver.
2. AMIPRE will provide one year warrantee for all products and three months warrantee for all repairing products.

# 11. OUTLINE DIMENSION

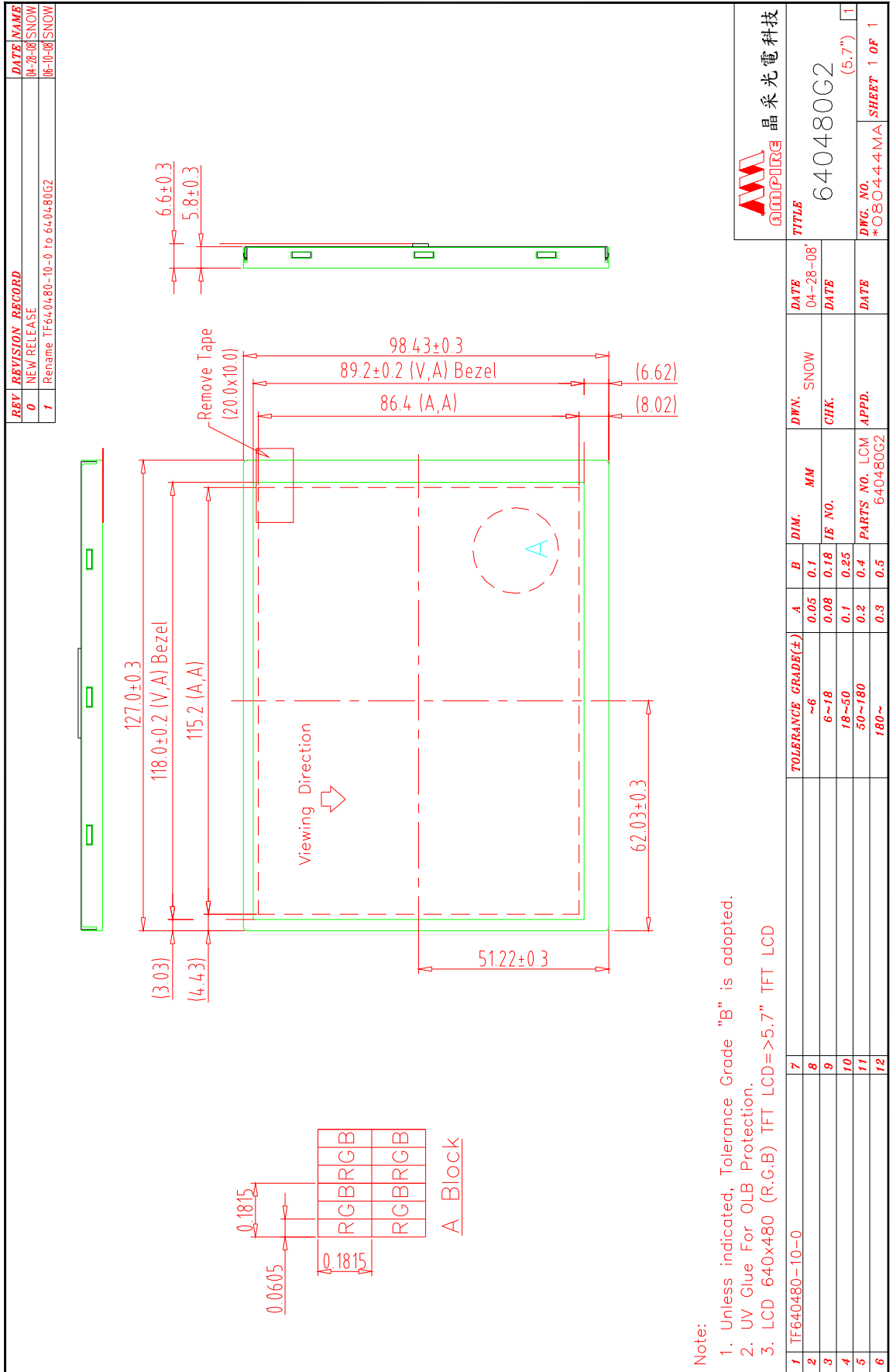

REV	REVISION RECORD	DATE	NAME
0	NEW RELEASE	04-28-08	SNOW
1	Rename TF640480-10-0 to 640480G2	08-10-08	SNOW

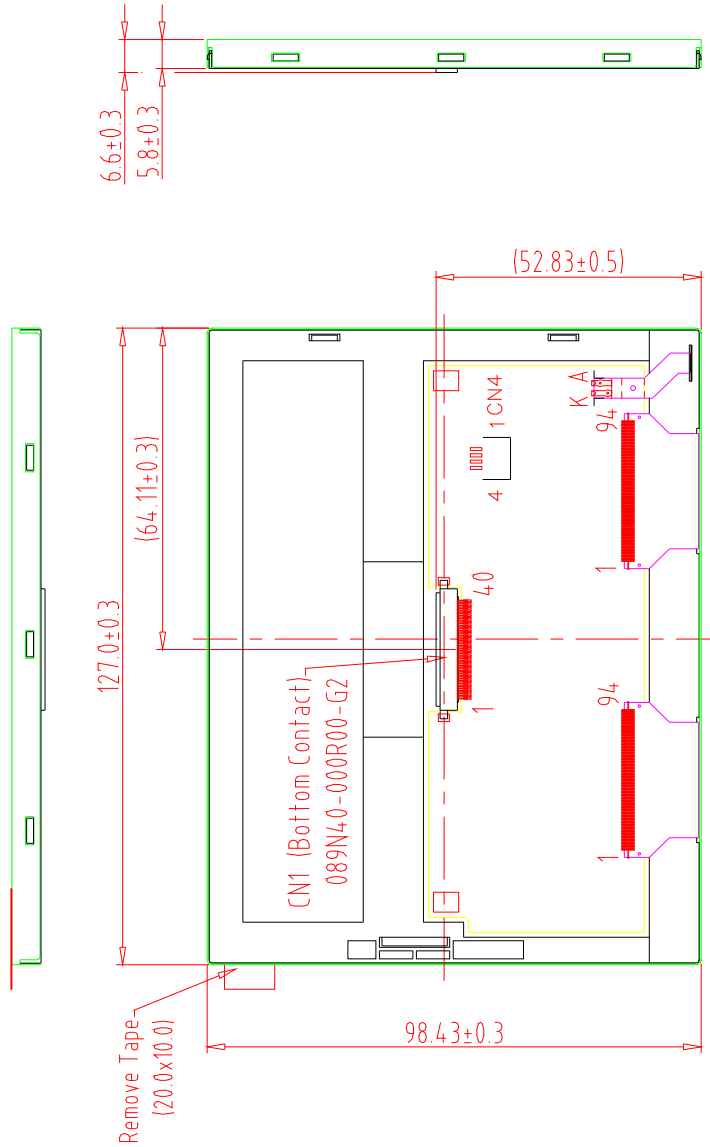

CN1			
1	U/D	21	G5
2	DMS(NC)	22	G4
3	HSYNC(NC)	23	G3
4	VLED	24	VSS
5	VLED	25	G2
6	VLED	26	G1
7	VCC	27	G0
8	VSNC(NC)	28	VSS
9	DE	29	R5
10	VSS	30	R4
11	VSS	31	R3
12	ADJ	32	VSS
13	B5	33	R2
14	B4	34	R1
15	B3	35	R0
16	VSS	36	VSS
17	B2	37	VSS
18	B1	38	DCLK
19	B0	39	VSS
20	VSS	40	L/R

Back view

Note:

1. Unless indicated, Tolerance Grade "B" is adopted.
2. UV Glue For OLB Protection.
3. LCD 640x480 (R.G.B) TFT LCD=>5.7" TFT LCD

NO.	DESCRIPTION	TOLERANCE GRADE(±)	A	B	DIM.	MM	DWN.	SNOW	DATE
7	TF640480-10-0	~6	0.05	0.1					04-28-08
8		6~18	0.08	0.18	IE NO.				DATE
9		18~50	0.1	0.25					
10		50~180	0.2	0.4	PARTS NO. LCM-1				
11		180~	0.3	0.5	640480G2				
12									



TITLE	640480G2
DWG. NO.	*0804-45MA
SHEET	1 OF 1