

## FEATURES

- Fixed DC output, 12V @17A (204W)
- Industry standard quarter brick 2.3" x 1.45" x 0.46" (58.4 x 36.8 x 11.7mm) package without baseplate (0.5" [12.7mm] with baseplate)
- Wide range Vin 18 to 75 Vdc
- Trimmable 10.8Vout to 13.2Vout @ 210W max.
- 2250 Volt Basic isolation
- Remote ON/Off enable control
- DOSA-compatible pinouts, with trim and sense
- High efficiency synchronous rectifier topology
- Stable no-load operation
- Monotonic startup into pre-bias output condition
- Certified to UL/EN 60950-1, CSA-C22.2 No. 60950-1, 2nd edition safety approvals
- Extensive self-protection, OVP, input undervoltage, current limiting and thermal shutdown

## PRODUCT OVERVIEW

The UWQ-12/17-Q48T series offers high output current (up to 17 Amps) in an industry standard "quarter brick" package requiring no heat sink for most applications. The UWQ-12/17-Q48T is trimmable from 10.8Vout to 13.2Vout and includes output sense pins to compensate for output voltage inaccuracy delivered at the load. The UWQ-12/17-Q48T series delivers fixed DC output voltages up to 204 Watts (12V @17A) for printed circuit board mounting. Wide range inputs of 18 to 75 Volts DC (48 Volts nominal) are ideal for wireless base stations, datacom, and telecom systems.

Advanced automated surface mount assembly, thermal management technology, and planar magnetics deliver high reliability galvanic isolation rated at 2250 Vdc for basic insulation. To power digital systems, the output delivers fast settling to current steps and stable operation where higher capacitive loads are required. Excellent ripple and

noise specifications deliver stable 12V BUS for IBC applications. For systems needing controlled startup/shutdown, an external remote On/Off control may use either positive or negative logic.

Several self-protection features include input undervoltage lockout, output overvoltage protection, and overtemperature shutdown (using an on-board temperature sensor); overcurrent protection using the "hiccup" autorestart technique provides indefinite short-circuit protection. The synchronous rectifier topology along with advanced thermal management delivers high efficiency for minimal heat generation and "no heat sink" operation.

The UWQ-12/17-Q48T series is certified to safety standards UL/EN/IEC/CSA 60950-1, 2nd edition. It meets Class B EMI conducted emission compliance to EN55022, CISPR22 with an external filter.

## APPLICATIONS

- Wireless base stations embedded systems, datacom and telecom installations
- Disk farms, data centers and cellular repeater sites
- Remote sensor systems
- Instrumentation systems, R&D platforms, automated test fixtures
- Data concentrators, voice forwarding and speech processing systems

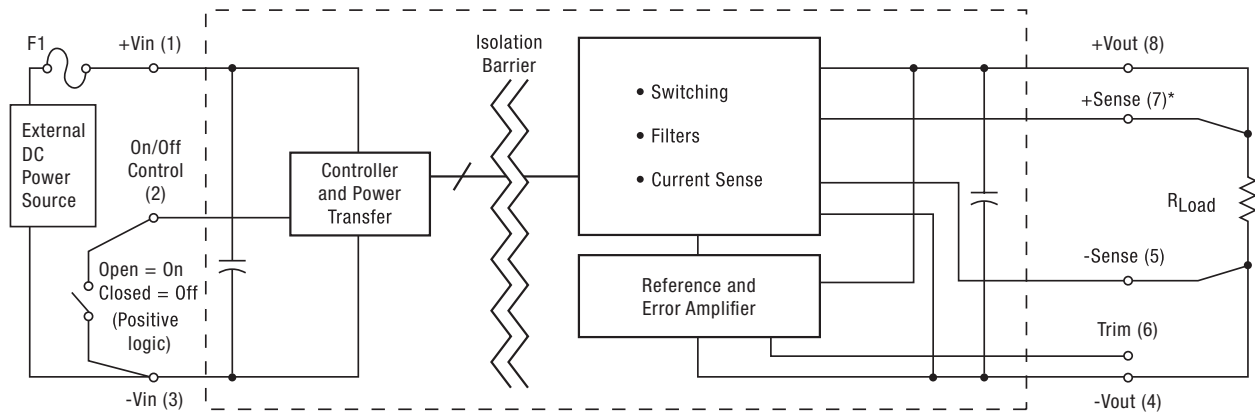

Figure 1. Connection Diagram

Typical topology is shown. Murata Power Solutions recommends an external fuse.



Wide Input, Isolated DOSA Quarter Brick DC-DC Converters with Trim and Sense

ORDERING GUIDE ①															
Root Model ①	Output						Input				Efficiency		Dimensions		
	V <sub>OUT</sub> (Volts)	I <sub>OUT</sub> (Amps, max.)	Power (Watts)	R/N (mV pk-pk)		Regulation (Max.) ②		V <sub>IN</sub> Nom. (Volts)	Range (Volts)	I <sub>IN</sub> no load (mA)	I <sub>IN</sub> full load (Amps)	Min.	Typ.	(inches)	(mm)
				Typ.	Max.	Line	Load								
UWQ-12/17-Q48T-C ②	12	17	204	100	120	±0.25%	±0.3%	48	18-75	80	4.62	90%	92%	2.30x1.45x0.46 max.	58.4x36.8x11.7

① Please refer to the part number structure for additional ordering information and options.  
 ② All specifications are typical at nominal line voltage and full load, +25°C unless otherwise noted. See

detailed specifications. Output capacitors are 1 µF || 10 µF with a 22µF input capacitor. These caps are necessary for our test equipment and may not be needed for your application.

## PART NUMBER STRUCTURE

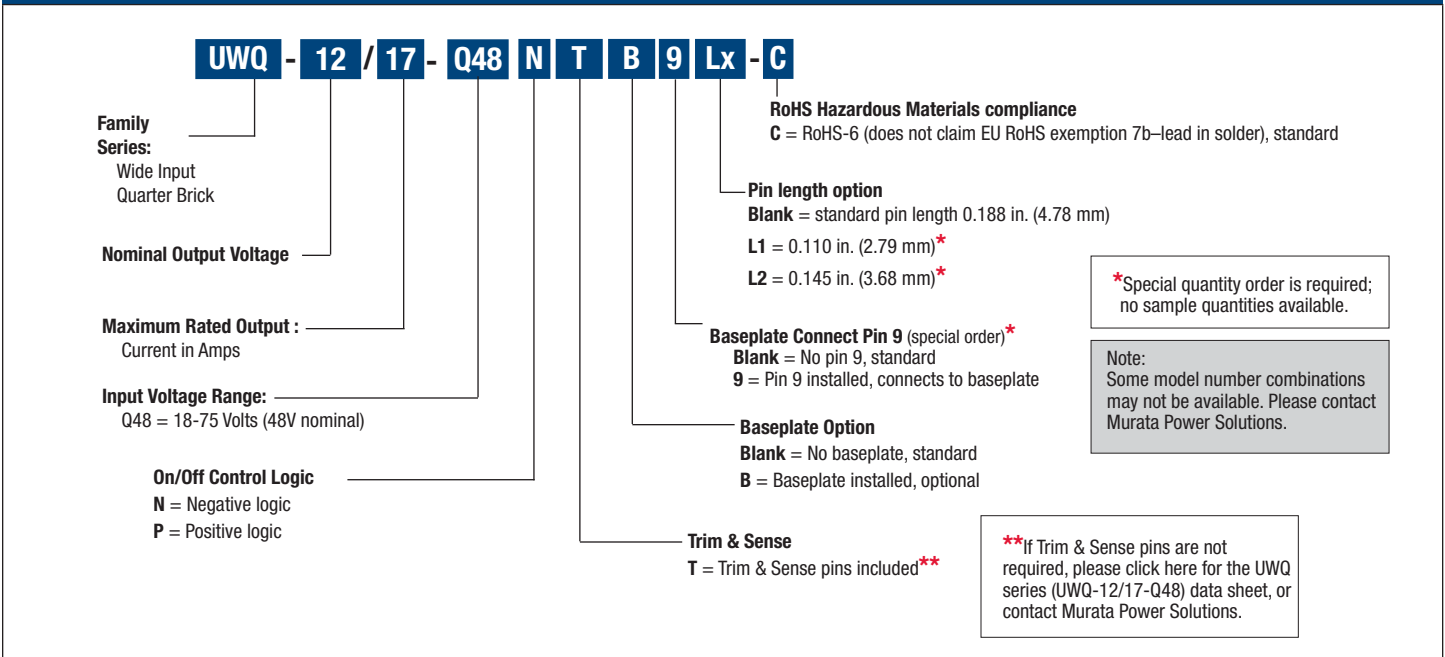

### UWQ Pin 9 Baseplate Connection

The UWQ module has an additional pin 9 on special order that connects to the baseplate but is electrically isolated from the rest of the converter. Please refer to the mechanical drawings. Pin 9 offers a positive method of controlling the electrical potential of the baseplate, independent of the converter.

The baseplate may be ordered by adding a "B" to the model number tree and pin 9 will be pre-installed by adding a "9." The two options are separate. Please refer to the Ordering Guide. Do not order pin 9 without the baseplate. Note that "pin 9" converters may be on limited forecast, requiring minimum order quantities and scheduled deliveries.

### Complete Model Number Example: **UWQ-12/17-Q48NTBL1-C**

Negative On/Off logic, trim & sense included, baseplate installed, 0.110" pin length, RoHS-6 compliance

## FUNCTIONAL SPECIFICATIONS

ABSOLUTE MAXIMUM RATINGS	Conditions/Comments ①	Minimum	Typical/Nominal	Maximum	Units
Input Voltage, Continuous	Full power operation	18	48	80	Vdc
Input Voltage, Transient	Operating or non-operating, 100 mS max. duration			100	Vdc
Isolation Voltage	Input to output			2250	Vdc
On/Off Remote Control	Power on or off, referred to -Vin	0		13.5	Vdc
Output Power		0		210.12	W
Output Current	Current-limited, no damage, short-circuit protected	0		17	A
Storage Temperature Range	Vin = Zero (no power)	-55		125	°C
Absolute maximums are stress ratings. Exposure of devices to greater than any of these conditions may adversely affect long-term reliability. Proper operation under conditions other than those listed in the Performance/Functional Specifications Table is not implied or recommended.					
INPUT		Conditions/Comments ① ③			
Operating voltage range		18	48	75	Vdc
Recommended External Fuse	Fast blow		20		A
Start-up threshold, measured at 50% load	Rising input voltage	16.5	17.5	17.9	Vdc
Undervoltage shutdown, measured at 50% load	Falling input voltage	15	16	17	Vdc
Overvoltage protection	N/A				
Internal Filter Type	L-C				
Input current					
Full Load Conditions	Vin = nominal		4.52	4.76	A
Low Line	Vin = minimum		12.06	12.69	A
Inrush Transient	Vin = 48V.		0.05	0.1	A2-Sec.
Short Circuit Input Current			50	100	mA
No Load input current	Iout = minimum, unit=ON		80	150	mA
Shut down mode input current			5	6.5	mA
Reflected (back) ripple current ②	Measured at input with specified filter		15	25	mA, RMS
Back Ripple Current, No Filtering			500	525	mA-p-p
Back Ripple Current, with 22µf external input capacitor			300	400	mA-p-p
GENERAL and SAFETY					
Efficiency	Vin=48V, full load	90	92		%
Isolation					
Isolation Voltage, input to output	With or without baseplate	2250			Vdc
Isolation Voltage, input to baseplate	With baseplate	1500			Vdc
Isolation Voltage, output to baseplate	With baseplate	1500			Vdc
Insulation Safety Rating	Basic				
Isolation Resistance			100		MΩ
Isolation Capacitance			1500		pF
Safety (certified to the following requirements)	UL-60950-1, CSA-C22.2 No.60950-1, IEC/EN60950-1, 2nd edition		Yes		
Calculated MTBF	Per Telcordia SR-332, issue 1, class 3, ground fixed, Tambient=+25°C		TBC		Hours x 10 <sup>3</sup>
DYNAMIC CHARACTERISTICS					
Fixed Switching Frequency		250	275	300	KHz
Startup Time	Power On, to Vout regulation band, 100% resistive load		60	65	mS
Startup Time	Remote ON to Vout Regulated		60	65	mS
Dynamic Load Response	50-75-50% load step to 3% of Vout		220	275	µSec
Dynamic Load Peak Deviation	same as above		±500	±700	mV
FEATURES and OPTIONS					
Remote On/Off Control ④					
"N" suffix:					
Negative Logic, ON state	ON = Pin connected to -Vin or to external source	0		1	Vdc
Negative Logic, OFF state	OFF = Pin open or connected to external voltage source	3.5		13.5	Vdc
Control Current	Open collector/drain		1	2	mA
"P" suffix:					
Positive Logic, ON state	ON = Pin open or connected to external voltage source	3.5		13.5	V
Positive Logic, OFF state	OFF = Pin connected to -Vin or to external voltage	0		1	V
Control Current	Open collector/drain		1	2	mA
Base Plate	"B" suffix				

## FUNCTIONAL SPECIFICATIONS, (CONT.)

OUTPUT	Conditions/Comments ①	Minimum	Typical/Nominal	Maximum	Units
<b>Total Output Power</b>		0.0	204	210	W
<b>Voltage</b>					
<b>Setting Accuracy, fixed output</b>	At 50% load, not user adjustable	11.64	12	12.36	Vdc
<b>Output Voltage Range</b>	User-adjustable	-10		+10	% of Vnom.
<b>Overvoltage Protection</b>	Via magnetic feedback			15	Vdc
<b>Current</b>					
<b>Output Current Range</b>		0.0	17	17	A
<b>Minimum Load</b>	No minimum load				
<b>Current Limit Inception</b>	97% of Vnom., cold condition	17.5	19.5	21.5	A
<b>Short Circuit</b>					
<b>Short Circuit Current</b>	Hiccup technique, autorecovery within 1.25% of Vout		5	6	A
<b>Short Circuit Duration (remove short for recovery)</b>	Output shorted to -Vout, no damage. Continuous operation				
<b>Short circuit protection method</b>	Hiccup technique-auto recovery				
<b>Regulation ⑤</b>					
<b>Line Regulation</b>	Vin=min. to max., Vout=nom., full load			±0.25	% of Vout
<b>Load Regulation</b>	Iout=min. to max., Vin=nom.			±0.3	% of Vout
<b>Ripple and Noise ⑥</b>	5 Hz- 20 MHz BW, Cout=1µF MLCC paralleled with 10µF tantalum		100	120	mV pk-pk
<b>Temperature Coefficient</b>	At all outputs		0.02		% of Vout./°C
<b>Maximum Capacitive Loading</b>	Low ESR caps	0	5000		µF
<b>Remote Sense Compliance</b>	Sense connected at load			10	% of Vout
<b>MECHANICAL (Through Hole Models)</b>					
<b>Outline Dimensions (open frame)</b>			2.3x1.45x0.46		Inches
			58.4x36.8x11.7		mm
<b>Outline Dimensions (with baseplate)</b>			2.3x1.45x0.5		Inches
			58.4x36.8x12.7		mm
<b>Weight</b>	With baseplate		2.12		Ounces
	With baseplate		60.19		Grams
	Without baseplate		1.6		Ounces
	Without baseplate		45.36		Grams
<b>Through Hole Pin Diameter</b>			0.04 & 0.06		Inches
			1.016 & 1.52		mm
<b>Through Hole Pin Material</b>	Copper alloy				
<b>TH Pin Plating Metal and Thickness</b>	Nickel subplate		50		µ-inches
	Gold overplate		5		µ-inches
<b>Baseplate Material</b>	Aluminum				
<b>ENVIRONMENTAL</b>					
<b>Operating Ambient Temperature Range</b>	See derating curves	-40		85	°C
<b>Operating Case Temperature</b>	With baseplate, no derating	-40		110	°C
<b>Storage Temperature</b>	Vin = Zero (no power)	-55		125	°C
<b>Thermal Protection/Shutdown</b>	Measured in center	115	125	130	°C
<b>Electromagnetic Interference</b>	External filter is required				
<b>Conducted, EN55022/CISPR22</b>	Class B with external filter				
<b>RoHS rating</b>	RoHS-6				

### Notes

- ① Unless otherwise noted, all specifications apply at Vin = nominal, nominal output voltage and full output load. General conditions are near sea level altitude, no base plate installed and natural convection airflow unless otherwise specified. All models are tested and specified with external parallel 1 µF and 10 µF multi-layer output capacitors and a 22µF external input capacitor (see Technical Notes). All capacitors are low-ESR types wired close to the converter. These capacitors are necessary for our test equipment and may not be needed in the user's application.
- ② Input (back) ripple current is tested and specified over 5 Hz to 20 MHz bandwidth. Input filtering is Cin = 33 µF/100V, Cbus = 220µF/100V and Lbus = 12 µH.

- ③ All models are stable and regulate to specification under no load.
- ④ The Remote On/Off Control is referred to -Vin.
- ⑤ Regulation specifications describe the output voltage changes as the line voltage or load current is varied from its nominal or midpoint value to either extreme. The load step is ±25% of full load current.
- ⑥ Output Ripple and Noise is measured with Cout = 1µF paralleled with 10µF, 20 MHz oscilloscope bandwidth and full resistive load.

Wide Input, Isolated DOSA Quarter Brick DC-DC Converters with Trim and Sense

## TYPICAL PERFORMANCE DATA

Efficiency vs. Line Voltage and Load Current @ 25°C

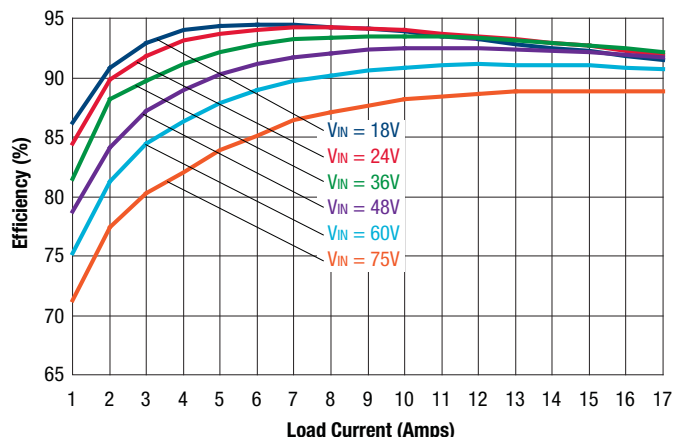

Power Dissipation @ 25°C

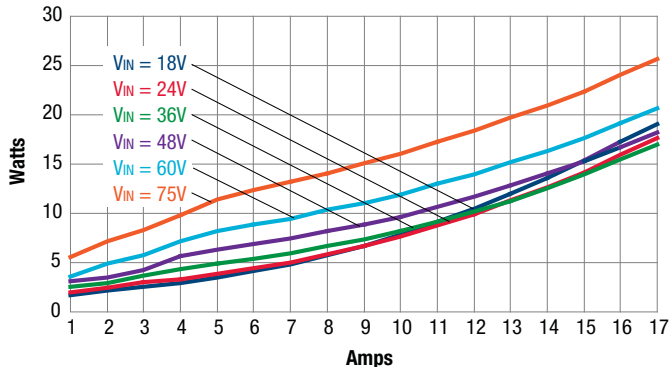

Maximum Current Temperature Derating at Sea Level (V<sub>in</sub> = 24V, airflow from pin 1 to pin 3, with baseplate)

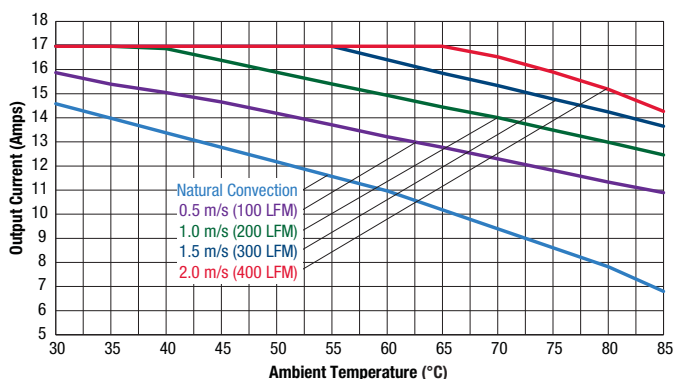

Maximum Current Temperature Derating at Sea Level (V<sub>in</sub> = 36V, airflow from pin 1 to pin 3, with baseplate)

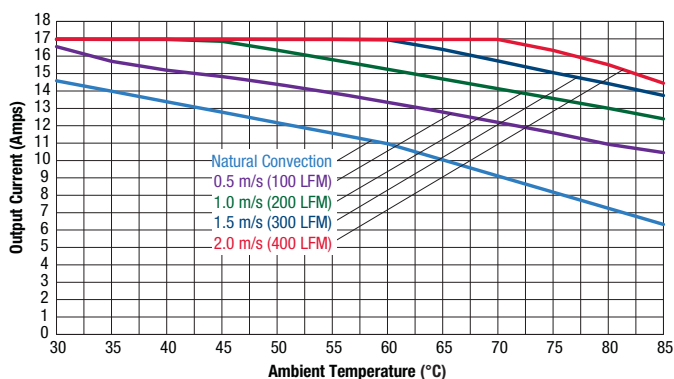

Maximum Current Temperature Derating at Sea Level (V<sub>in</sub> = 48V, airflow from pin 1 to pin 3, with baseplate)

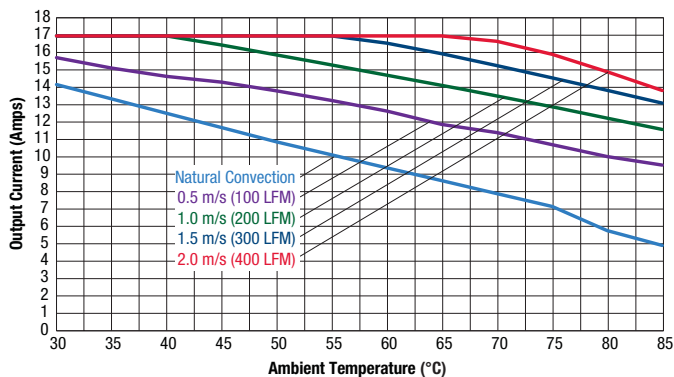

Maximum Current Temperature Derating at Sea Level (V<sub>in</sub> = 60V, airflow from pin 1 to pin 3, with baseplate)

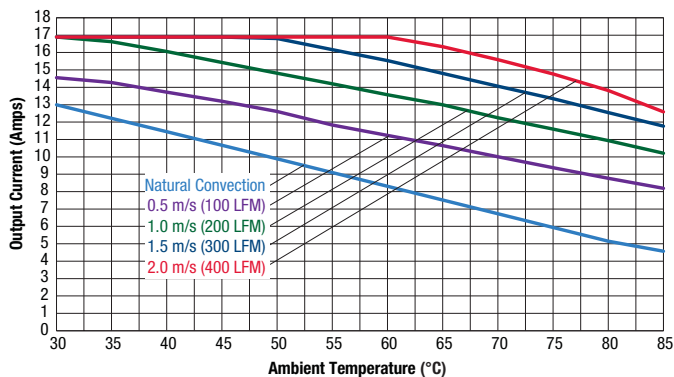

Wide Input, Isolated DOSA Quarter Brick DC-DC Converters with Trim and Sense

## TYPICAL PERFORMANCE DATA

**Maximum Current Temperature Derating at Sea Level**  
(Vin= 24V, airflow from pin 1 to pin 3, without baseplate)

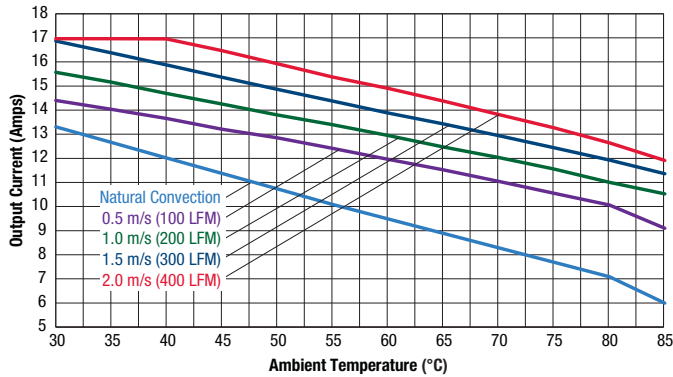

**Maximum Current Temperature Derating at Sea Level**  
(Vin= 36V, airflow from pin 1 to pin 3, without baseplate)

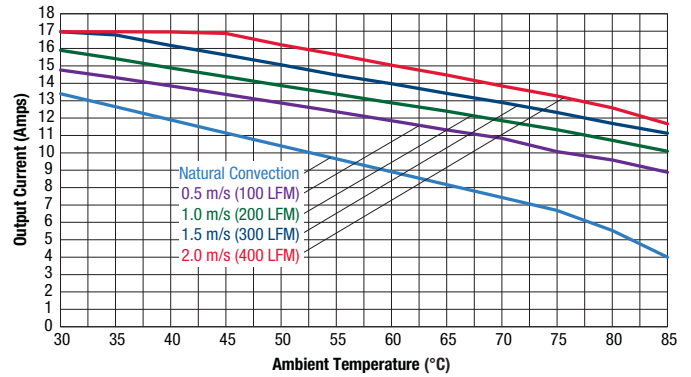

**Maximum Current Temperature Derating at Sea Level**  
(Vin= 48V, airflow from pin 1 to pin 3, without baseplate)

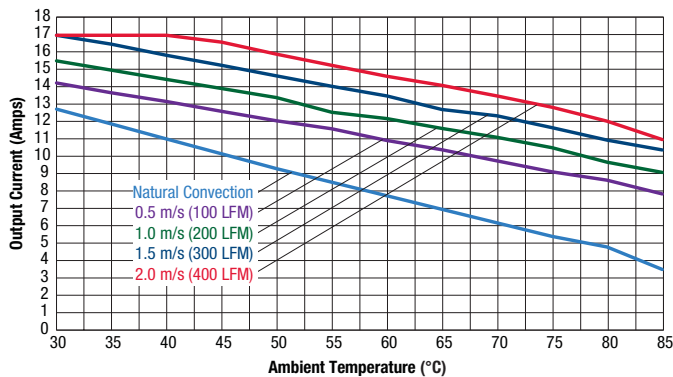

**Maximum Current Temperature Derating at Sea Level**  
(Vin= 60V, airflow from pin 1 to pin 3, without baseplate)

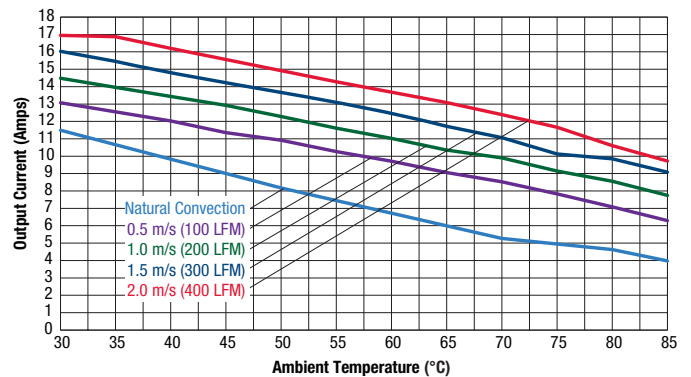

Wide Input, Isolated DOSA Quarter Brick DC-DC Converters with Trim and Sense

## TYPICAL PERFORMANCE DATA

Start-up Delay (Vin=48V, Iout=17A, Ta=+25°C) Ch1=Vin, Ch2=Vout

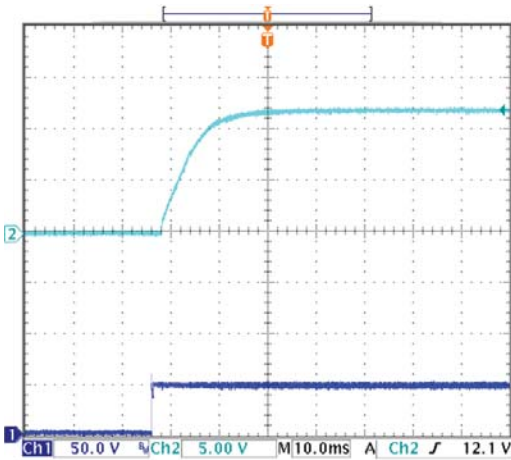

Start-up Delay (Vin=48V, Iout=0A, Load=5000µF, Ta=+25°C) Ch1=Vin, Ch2=Vout

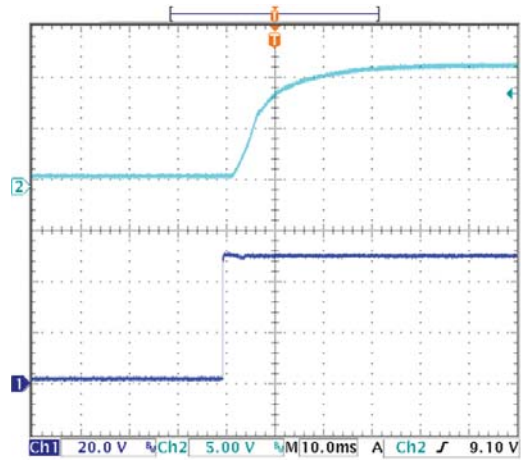

Start-up Delay (Vin=48V, Iout=17A, Load=5000µF, Ta=+25°C) Ch1=Vin, Ch2=Vout

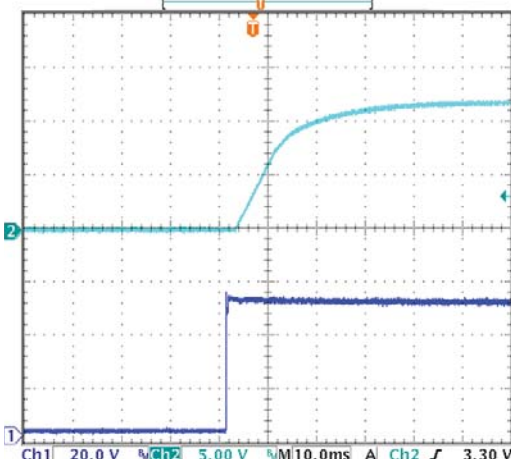

On/Off Enable delay (Vin=48V, Vout=nom, Iout=17A, Ta=+25°C) Ch1=Enable, Ch2=Vout

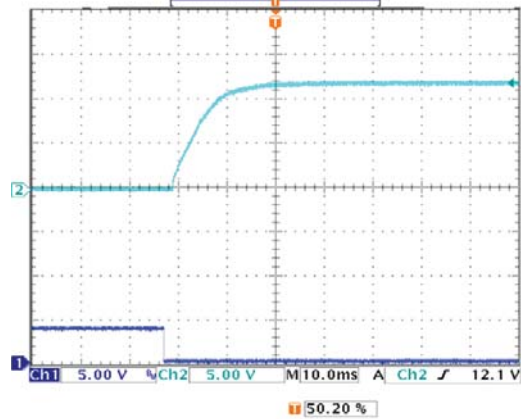

On/Off Enable delay (Vin=48V, Vout=nom, Iout=0A, Load=6000µF, Ta=+25°C) Ch1=Enable, Ch2=Vout

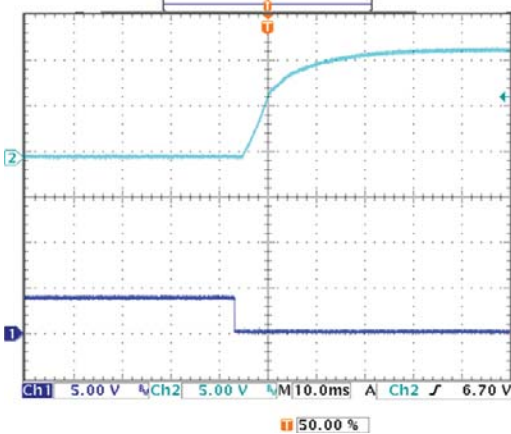

On/Off Enable delay (Vin=48V, Vout=nom, Iout=17A, Load=6000µF, Ta=+25°C) Ch1=Enable, Ch2=Vout

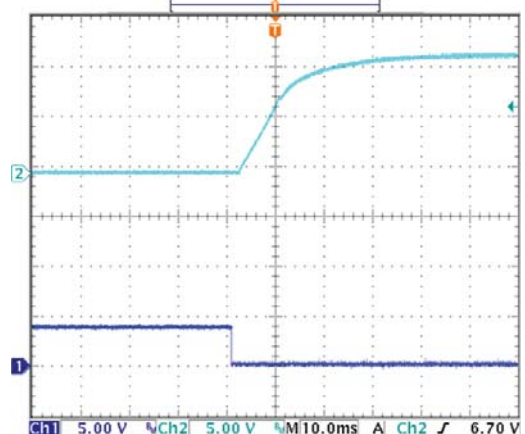

Wide Input, Isolated DOSA Quarter Brick DC-DC Converters with Trim and Sense

## TYPICAL PERFORMANCE DATA

Stepload Transient Response ( $V_{in}=48V$ ,  $I_{out}=50-75-50\%$  of  $I_{max}$ ,  $C_{load}=1\mu F \parallel 10\mu F$ ,  $I_o=5A/div$ ,  $T_a=+25^\circ C$ ) Ch2=Vout, Ch4=Iout

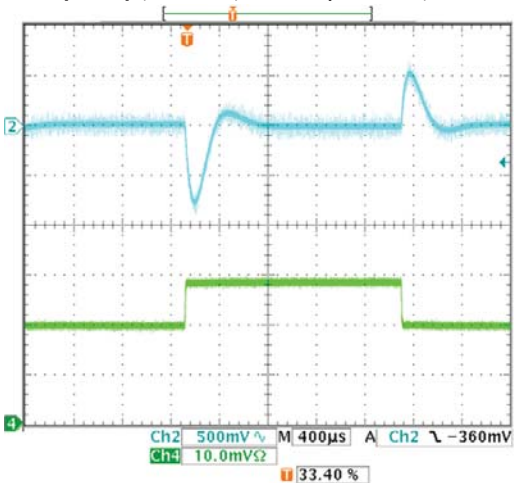

Stepload Transient Response ( $V_{in}=48V$ ,  $I_{out}=50-75-50\%$  of  $I_{max}$ ,  $C_{load}=6000\mu F$ ,  $I_o=5A/div$ ,  $T_a=+25^\circ C$ ) Ch2=Vout, Ch4=Iout

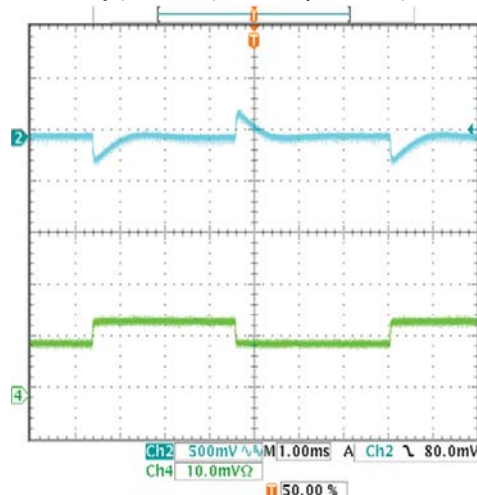

Output Ripple & Noise ( $V_{in}=48V$ ,  $I_{out}=0A$ ,  $C_{load}=1\mu F \parallel 10\mu F$ ,  $T_a=+25^\circ C$ ,  $BW=20MHz$ )

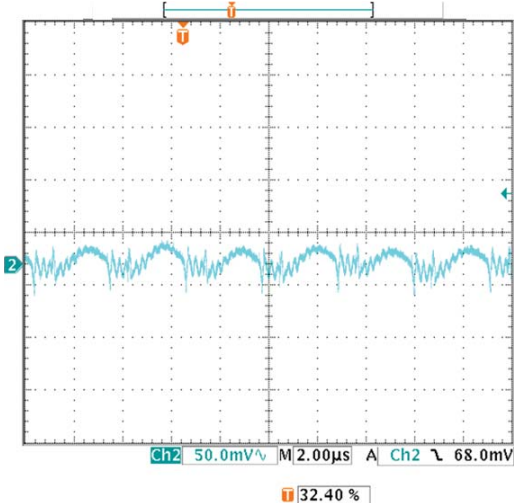

Output Ripple & Noise ( $V_{in}=48V$ ,  $I_{out}=17A$ ,  $C_{load}=1\mu F \parallel 10\mu F$ ,  $T_a=+25^\circ C$ ,  $BW=20MHz$ )

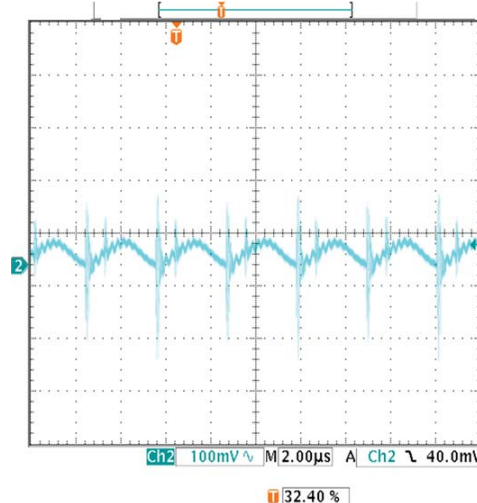

Pre-biased Output Voltage Startup Operation ( $V_{in}=48Vdc$ ,  $I_{out}=0A$ ,  $C_{out}=5000\mu F$ ,  $T_a=+25^\circ C$ ) Ch1=Vin, Ch2=Vout.

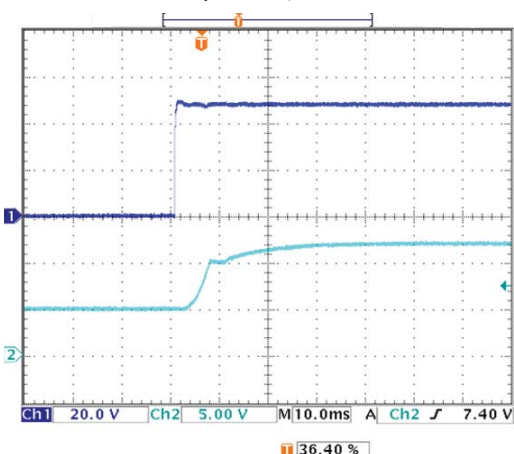

Thermal image with hot spot at 9.22A with 25°C ambient temperature. Natural convection is used with no forced airflow. Identifiable and recommended maximum value to be verified in application.

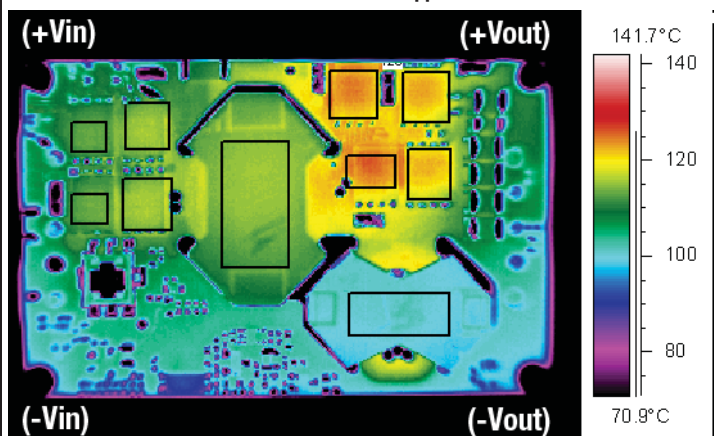



## MECHANICAL SPECIFICATIONS – OPEN FRAME

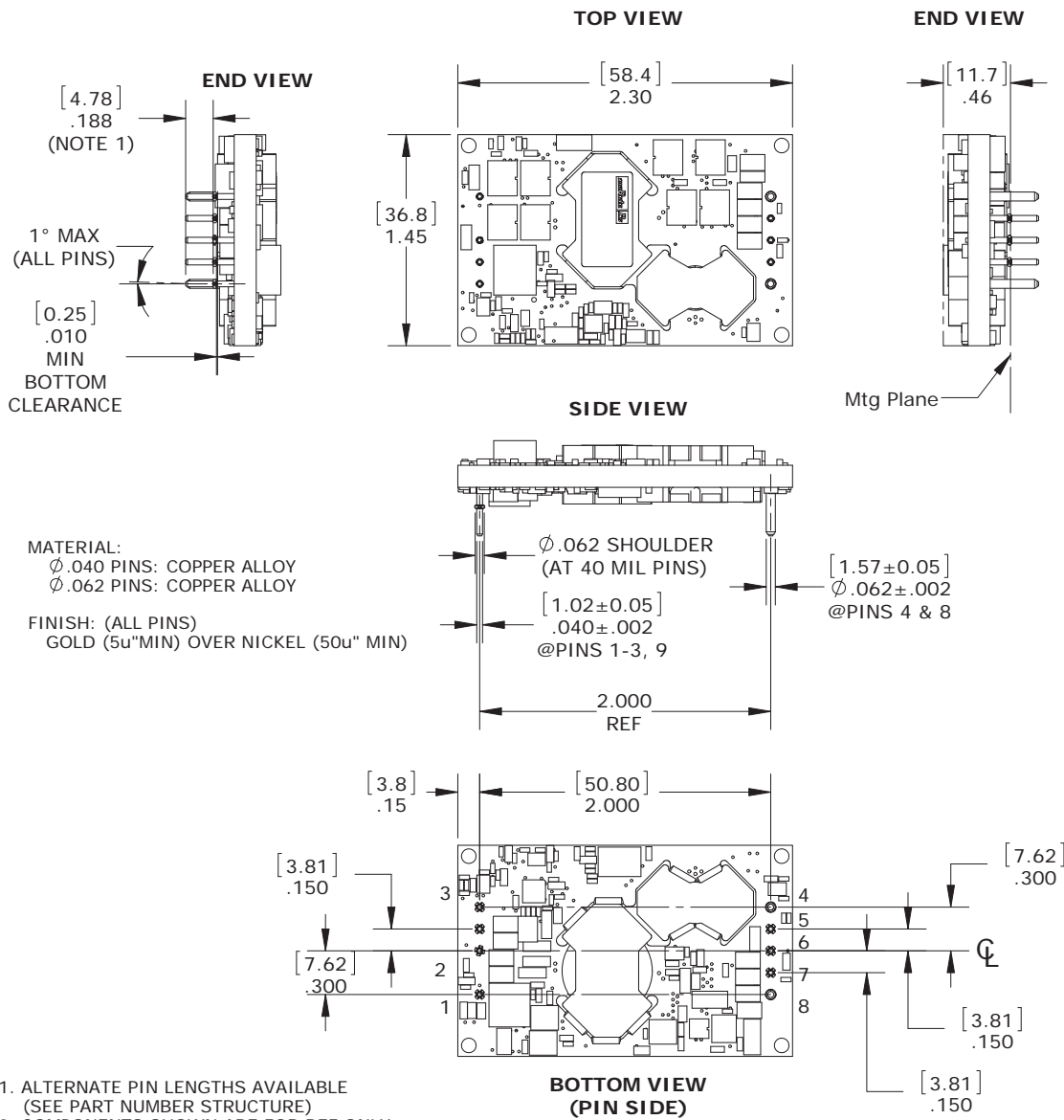

1. ALTERNATE PIN LENGTHS AVAILABLE (SEE PART NUMBER STRUCTURE)
2. COMPONENTS SHOWN ARE FOR REF ONLY
3. DIMENSIONS ARE IN INCHES [mm]
4. PIN LOCATION DIMENSIONS APPLY AT CIRCUIT BOARD LEVEL
5. THESE CONVERTERS MEET THE MECHANICAL SPECIFICATIONS OF A QUARTER BRICK DC-DC CONVERTER

### INPUT/OUTPUT CONNECTIONS

Pin	Function
1	+Vin
2	Remote On/Off *
3	-Vin
4	-Vout
5	-Sense
6	Trim
7	+Sense
8	+Vout
9	No pin

\*The Remote On/Off can be provided with either positive (P suffix) or negative (N suffix) logic.

Dimensions are in inches (mm shown for ref. only).

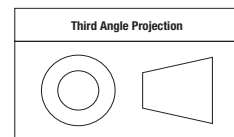

Tolerances (unless otherwise specified):  
 .XX ± 0.02 (0.5)  
 .XXX ± 0.010 (0.25)  
 Angles ± 2°

Components are shown for reference only and may vary between units.

## MECHANICAL SPECIFICATIONS – WITH BASEPLATE

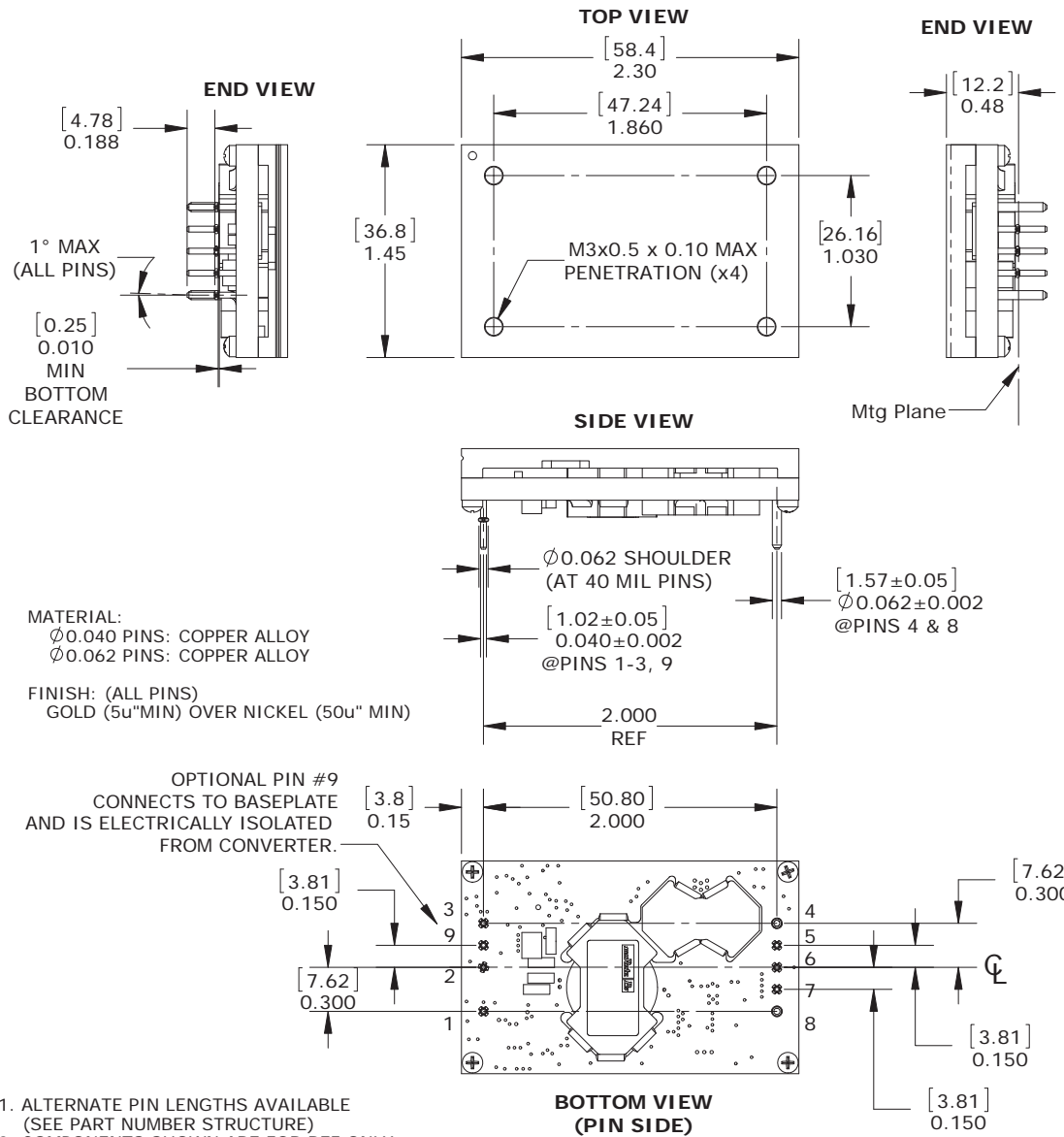

**MATERIAL:**  
 Ø0.040 PINS: COPPER ALLOY  
 Ø0.062 PINS: COPPER ALLOY

**FINISH: (ALL PINS)**  
 GOLD (5u"MIN) OVER NICKEL (50u" MIN)

1. ALTERNATE PIN LENGTHS AVAILABLE (SEE PART NUMBER STRUCTURE)
2. COMPONENTS SHOWN ARE FOR REF ONLY
3. DIMENSIONS ARE IN INCHES [mm]
4. PIN LOCATION DIMENSIONS APPLY AT CIRCUIT BOARD LEVEL
5. THESE CONVERTERS MEET THE MECHANICAL SPECIFICATIONS OF A QUARTER BRICK DC-DC CONVERTER

### INPUT/OUTPUT CONNECTIONS

Pin	Function
1	+Vin
2	Remote On/Off *
3	-Vin
4	-Vout
5	-Sense
6	Trim
7	+Sense
8	+Vout
9	Baseplate (Optional)

\*The Remote On/Off can be provided with either positive (P suffix) or negative (N suffix) logic.

Dimensions are in inches (mm shown for ref. only).

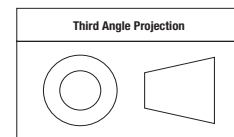

Tolerances (unless otherwise specified):  
 .XX ± 0.02 (0.5)  
 .XXX ± 0.010 (0.25)  
 Angles ± 2°

Components are shown for reference only and may vary between units.

**MECHANICAL SPECIFICATIONS**

**RECOMMENDED FOOTPRINT  
(VIEW THROUGH CONVERTER)**  
REF: DOSA STANDARD SPECIFICATION  
FOR QUARTER BRICK DC/DC CONVERTERS

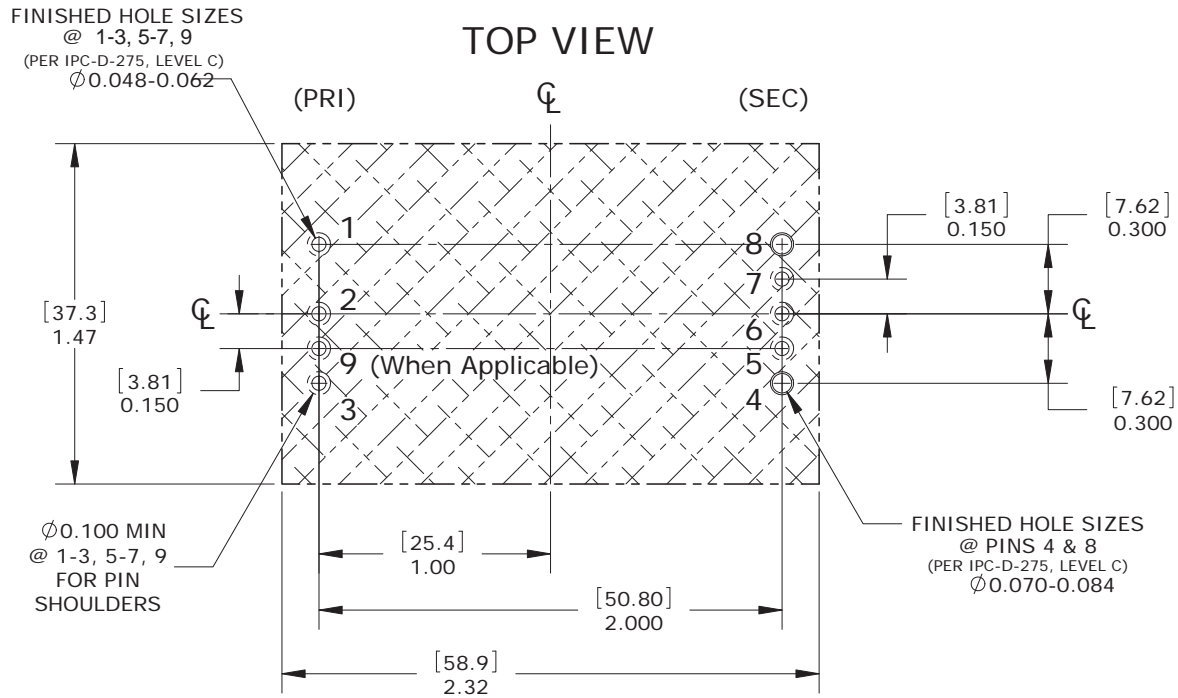

IT IS RECOMMENDED THAT NO PARTS  
BE PLACED BENEATH CONVERTER  
(HATCHED AREA)

Dimensions are in inches (mm shown for ref. only).

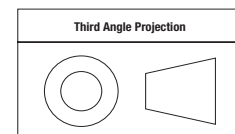

Tolerances (unless otherwise specified):  
.XX ± 0.02 (0.5)  
.XXX ± 0.010 (0.25)  
Angles ± 2°

Components are shown for reference only  
and may vary between units.

**STANDARD PACKAGING**

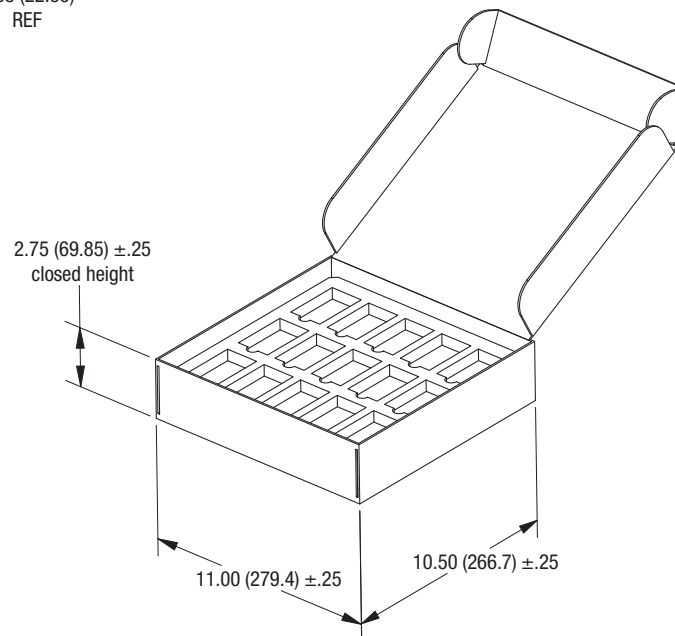
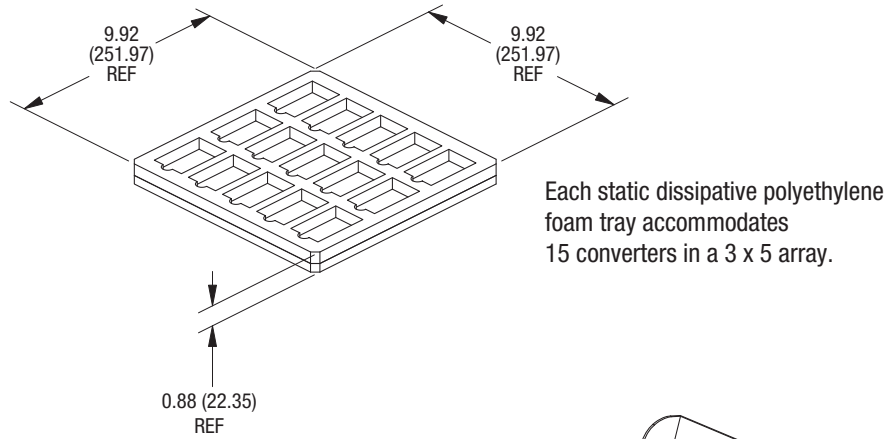

Carton accommodates two (2) trays yielding 30 converters per carton

Dimensions are in inches (mm) shown for ref. only.

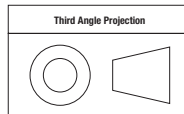

Tolerances (unless otherwise specified):  
 .XX ± 0.02 (0.5)  
 .XXX ± 0.010 (0.25)  
 Angles ± 2'

## Wide Input, Isolated DOSA Quarter Brick DC-DC Converters with Trim and Sense

**TECHNICAL NOTES**

### Input Fusing

Certain applications and/or safety agencies may require fuses at the inputs of power conversion components. Fuses should also be used when there is the possibility of sustained input voltage reversal which is not current-limited. For greatest safety, we recommend a fast blow fuse installed in the +Vin supply line.

The installer must observe all relevant safety standards and regulations. For safety agency approvals, install the converter in compliance with the end-user safety standard.

### Input Under-Voltage Shutdown and Start-Up Threshold

Under normal start-up conditions, converters will not begin to regulate properly until the rising input voltage exceeds and remains above the Start-Up Threshold Voltage (see Specifications). Once operating, converters will not turn off until the input voltage drops below the Under-Voltage Shutdown Limit. Subsequent restart will not occur until the input voltage rises again above the Start-Up Threshold. This built-in hysteresis prevents any unstable on/off operation at a single input voltage.

Users should be aware however of input sources near the Under-Voltage Shutdown whose voltage decays as input current is consumed (such as capacitor inputs), the converter shuts off and then restarts as the external capacitor recharges. Such situations could oscillate. To prevent this, make sure the operating input voltage is well above the UV Shutdown voltage AT ALL TIMES.

### Start-Up Delay

Assuming that the output current is set at the rated maximum, the Vin to Vout Start-Up Delay (see Specifications) is the time interval between the point when the rising input voltage crosses the Start-Up Threshold and the fully loaded regulated output voltage enters and remains within its specified regulation band. Actual measured times will vary with input source impedance, external input capacitance, input voltage slew rate and final value of the input voltage as it appears at the converter.

These converters include a soft start circuit to moderate the duty cycle of the PWM controller at power up, thereby limiting the input and output inrush current.

The On/Off Remote Control interval from inception to Vout regulated assumes that the converter already has its input voltage stabilized above the Start-Up Threshold before the On command. The interval is measured from the On command until the output enters and remains within its specified regulation band. The specification assumes that the output is fully loaded at maximum rated current.

### Input Source Impedance

These converters will operate to specifications without external components, assuming that the source voltage has very low impedance. Since real-world voltage sources have finite minimum impedance, performance is improved by adding external filter components. Sometimes only a small ceramic input capacitor is sufficient. Since it is difficult to totally characterize all applications, some experimentation may be needed. Note that external input capacitors must accept high speed switching currents.

Performance will degrade with increasing input inductance. Excessive input inductance may inhibit operation. The DC input regulation specifies that the input voltage, once operating, must never degrade below the Shut-Down

Threshold under all load conditions. Be sure to use adequate trace sizes and mount components close to the converter.

### I/O Filtering, Input Ripple Current and Output Noise

All models in this converter series are tested and specified for input reflected ripple current and output noise using designated external input/output components, circuits and layout as shown in the figures below. External input capacitors (CIN in the figure) serve primarily as energy storage elements, minimizing line voltage variations caused by transient IR drops in the input conductors. Users should select input capacitors for bulk capacitance (at appropriate frequencies), low ESR and high RMS ripple current ratings. In the figure below, the CBUS and LBUS components simulate a typical DC voltage bus. Specific system configurations may require additional considerations. Please note that the values of CIN, LBUS and CBUS may vary according to the specific converter model.

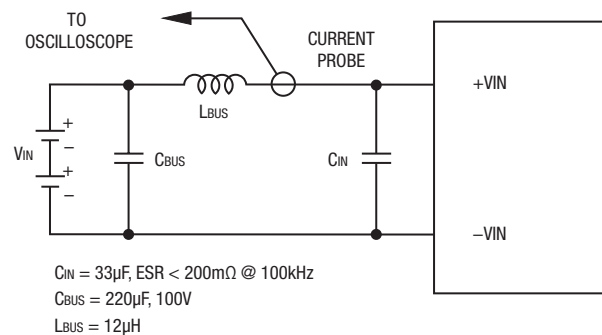

**Figure 2. Measuring Input Ripple Current**

In critical applications, output ripple and noise (also referred to as periodic and random deviations or PARD) may be reduced by adding filter elements such as multiple external capacitors. Be sure to calculate component temperature rise from reflected AC current dissipated inside capacitor ESR. In order to minimize circuit errors and standardize tests between units, scope measurements should be made using BNC connectors or the probe ground should not exceed one half inch and soldered directly to the fixture.

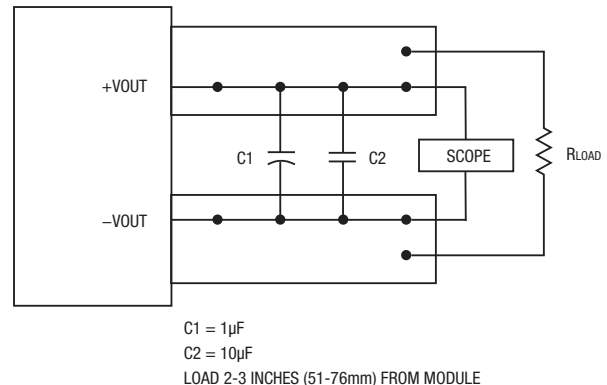

**Figure 3. Measuring Output Ripple and Noise (PARD)**

## Wide Input, Isolated DOSA Quarter Brick DC-DC Converters with Trim and Sense

### Floating Outputs

Since these are isolated DC-DC converters, their outputs are “floating” with respect to their input. The essential feature of such isolation is ideal ZERO CURRENT FLOW between input and output. Real-world converters however do exhibit tiny leakage currents between input and output. These leakages consist of both an AC stray capacitance coupling component and a DC leakage resistance. When using the isolation feature, do not allow the isolation voltage to exceed specifications. Otherwise the converter may be damaged. Designers will normally use the negative output (-Output) as the ground return of the load circuit. You can however use the positive output (+Output) as the ground return to effectively reverse the output polarity.

### Minimum Output Loading Requirements

These converters employ a synchronous rectifier design topology. All models regulate within specification and are stable under no load to full load conditions. Operation under no load might however slightly increase output ripple and noise.

### Thermal Shutdown

To protect against thermal over-stress, these converters include thermal shutdown circuitry. If environmental or application conditions cause the temperature of the DC-DC's to rise above the Operating Temperature Range up to the shutdown temperature, an on-board electronic temperature sensor will power down the unit. When the temperature decreases below the turn-on threshold, the converter will automatically restart. There is a small amount of hysteresis to prevent rapid on/off cycling. CAUTION: If the product is operated too close to the thermal limits, it may shut down suddenly without warning. Be sure to thoroughly test your application to avoid unplanned thermal shutdown.

### Temperature Derating Curves

The graphs in this data sheet illustrate typical operation under a variety of conditions. The Derating curves show the maximum continuous ambient air temperature and decreasing maximum output current which is acceptable under increasing forced airflow measured in Linear Feet per Minute (“LFM”) or meters per second (M/S). Note that these are AVERAGE, steady state measurements. The converter will accept brief increases in temperature and/or current or reduced airflow as long as the average is not exceeded.

Note that the temperatures are of the ambient airflow, not the converter itself which is obviously running at higher temperature than the outside air. Also note that “natural convection” is defined as very low flow rates which are not using fan-forced airflow. Depending on the application, “natural convection” is usually about 30-65 LFM but is not equal to still air (0 LFM).

Murata Power Solutions makes Characterization measurements in a closed cycle wind tunnel with calibrated airflow. Both thermocouples and an infrared camera system are used to observe thermal performance.

CAUTION: If these Derating guidelines are exceeded, the converter may have an unplanned Over Temperature shut down. Also, these graphs are all collected near Sea Level altitude. Be sure to reduce the derating for higher altitude.

### Output Overvoltage Protection (OVP)

This converter monitors its output voltage for an over-voltage condition using magnetic feedback circuitry. If the output exceeds OVP limits, the sensing circuit will power down the unit, and the output voltage will decrease. After a time-out period, the PWM will automatically attempt to restart, causing the output voltage to ramp up to its rated value. It is not necessary to power down and reset the converter for this automatic OVP-recovery restart.

If the fault condition persists and the output voltage climbs to excessive levels, the OVP circuitry will initiate another shutdown cycle. This on/off cycling is referred to as “hiccup” mode.

### Output Fusing

The converter is extensively protected against current, voltage and temperature extremes. However, your application circuit may need additional protection. In the extremely unlikely event of output circuit failure, excessive voltage could be applied to the application circuit. Consider using an appropriate external protection.

### Current Limiting

As power demand increases on the output and enters the specified “limit inception range” limiting circuitry activates in the DC-DC converter to limit/restrict the maximum current or total power available. Once the current reaches a certain range the output voltage will start to decrease while the output current continues to increase, thereby maintaining constant power, until a maximum peak current is reached and the converter enters a “hiccup” (on off cycling) mode of operation until the load is reduced below the threshold level, whereupon it will return to a normal mode of operation. Current limit inception is defined as the point where the output voltage has decreased by a pre-specified percentage (usually a 2% decrease from nominal).

### Short Circuit Condition

The short circuit condition is an extension of the “Current Limiting” condition. When the monitored peak current signal reaches a certain range, the PWM controller's outputs are shut off thereby turning the converter “off.” This is followed by an extended time out period. This period can vary depending on other conditions such as the input voltage level. Following this time out period, the PWM controller will attempt to re-start the converter by initiating a “normal start cycle” which includes softstart. If the “fault condition” persists, another “hiccup” cycle is initiated. This “cycle” can and will continue indefinitely until such time as the “fault condition” is removed, at which time the converter will resume “normal operation.” Operating in the “hiccup” mode during a fault condition is advantageous in that average input and output power levels are held low preventing excessive internal increases in temperature.

### Trimming Output Voltage

UWQ converters have a trim capability (pin 6) that enables users to adjust the output voltage from +10% to -10% (refer to the trim equations in the table below). Adjustments to the output voltage can be accomplished with a single fixed resistor as shown in Figures 4 and 5. A single fixed resistor can increase or decrease the output voltage depending on its connection. Resistors should be located close to the converter and have TCR's less than 100ppm/°C to minimize sensitivity to changes in temperature. If the trim function is not used, leave the trim pin open.

Standard UWQs have a “positive trim” where a single resistor connected from the Trim pin (pin 6) to the +Sense (pin 7) will increase the output voltage. A resistor connected from the Trim Pin (pin 6) to the -Sense (pin 5) will decrease the output voltage.

Trim adjustments greater than the specified +10%/-10% can have an adverse affect on the converter's performance and are not recommended. Excessive voltage differences between  $V_{OUT}$  and Sense, in conjunction with trim adjustment of the output voltage, can cause the overvoltage protection circuitry to activate (see Performance Specifications for overvoltage limits).

Temperature/power derating is based on maximum output current and voltage at the converter's output pins. Use of the trim and sense functions can cause output voltages to increase, thereby increasing output power beyond the UWQ's specified rating, or cause output voltages to climb into the output overvoltage region. Therefore:

$$(V_{out \text{ at pins}}) \times (I_{out}) \leq \text{rated output power}$$

The Trim pin (pin 6) is a relatively high impedance node that can be susceptible to noise pickup when connected to long conductors in noisy environments.

Trim Up*	Trim Down*
$R_{T_{UP}} \text{ (k}\Omega\text{)} = \frac{49.6(V_O - 1.226)}{V_O - 12} - 10.2$	$R_{T_{DOWN}} \text{ (k}\Omega\text{)} = \frac{60.45}{12 - V_O} - 10.2$

\*Vo = Desirable output voltage in Volts

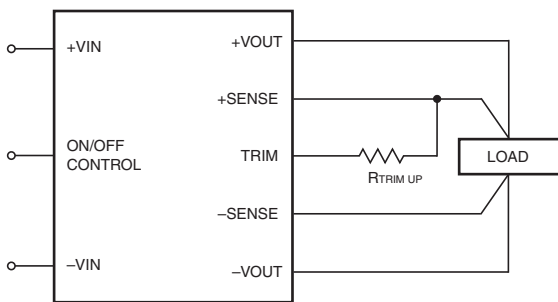

Figure 4. Trim Connections To Increase Output Voltages Using Fixed Resistors

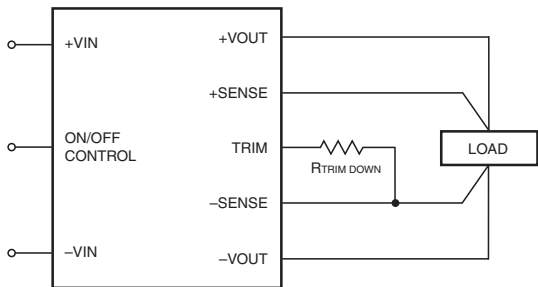

Figure 5. Trim Connections To Decrease Output Voltages Using Fixed Resistors

**Remote Sense Input**

Use the Sense inputs with caution. Sense is normally connected **at the load**. Sense inputs compensate for output voltage inaccuracy delivered at the load. This is done by correcting IR voltage drops along the output wiring and the current carrying capacity of PC board etc. This output drop (the difference between Sense and Vout when measured at the converter) should not exceed 0.5V. Consider using heavier wire if this drop is excessive. Sense inputs also improve the stability of the converter and load system by optimizing the control loop phase margin.

Note: The Sense input and power Vout lines are internally connected through low value resistors to their respective polarities so that the converter can operate without external connection to the Sense. Nevertheless, if the Sense

**Wide Input, Isolated DOSA Quarter Brick DC-DC Converters with Trim and Sense**

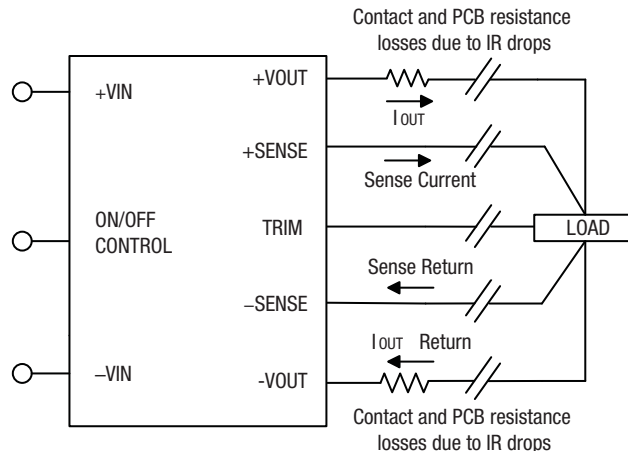

Figure 6. Remote Sense Circuit Configuration

function is not used for remote regulation, the user should connect +Sense to +Vout and -Sense to -Vout at the converter pins.

The remote Sense lines carry very little current. They are also capacitively coupled to the output lines and therefore are in the feedback control loop to regulate and stabilize the output. As such, they are not low impedance inputs and must be treated with care in PC board layouts. Sense lines on the PCB should run adjacent to DC signals, preferably Ground. In cables and discrete wiring, use twisted pair, shielded tubing or similar techniques.

Any long, distributed wiring and/or significant inductance introduced into the Sense control loop can adversely affect overall system stability. If in doubt, test your applications by observing the converter's output transient response during step loads. There should not be any appreciable ringing or oscillation. You may also adjust the output trim slightly to compensate for voltage loss in any external filter elements. Do not exceed maximum power ratings.

**Remote On/Off Control**

On the input side, a remote On/Off Control can be specified with either positive or negative logic as follows:

Models are on (enabled) when the On/Off is grounded or brought to within a low voltage (see Specifications) with respect to -Vin. The device is off (disabled) when the On/Off is left open or is pulled high to +13.5Vdc Max. with respect to -Vin.

Dynamic control of the On/Off function should be able to sink the specified signal current when brought low and withstand specified voltage when brought high. Be aware too that there is a finite time in milliseconds (see Specifications) between the time of On/Off Control activation and stable, regulated output. This time will vary slightly with output load type and current and input conditions.

There are two CAUTIONs for the On/Off Control:

**CAUTION:** While it is possible to control the On/Off with external logic if you carefully observe the voltage levels, the preferred circuit is either an open drain/open collector transistor or a relay (which can thereupon be controlled by logic). The On/Off prefers to be set at approx. +13.5V (open pin) for the ON state, assuming positive logic.

## Wide Input, Isolated DOSA Quarter Brick DC-DC Converters with Trim and Sense

**CAUTION:** Do not apply voltages to the On/Off pin when there is no input power voltage. Otherwise the converter may be permanently damaged.

Please observe Sense inputs tolerance to avoid improper operation:

$$[V_{out(+)} - V_{out(-)}] - [Sense(+)-Sense(-)] \leq 10\% \text{ of } V_{out}$$

Output overvoltage protection is monitored at the output voltage pin, not the Sense pin. Therefore excessive voltage differences between Vout and Sense together with trim adjustment of the output can cause the overvoltage protection circuit to activate and shut down the output.

Power derating of the converter is based on the combination of maximum output current and the highest output voltage. Therefore the designer must ensure:

$$(V_{out \text{ at pins}}) \times (I_{out}) \leq (\text{Max. rated output power})$$

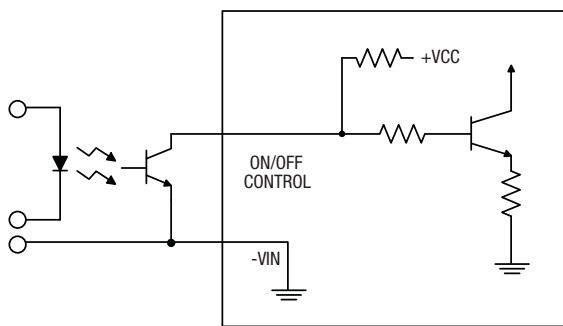

Figure 7. Driving the On/Off Control Pin (suggested circuit)

### Emissions Performance

Murata Power Solutions measures its products for radio frequency emissions against the EN 55022 and CISPR 22 standards. Passive resistance loads are employed and the output is set to the maximum voltage. If you set up your own emissions testing, make sure the output load is rated at continuous power while doing the tests.

The recommended external input and output capacitors (if required) are included. Please refer to the fundamental switching frequency. All of this information is listed in the Product Specifications. An external discrete filter is installed and the circuit diagram is shown below.

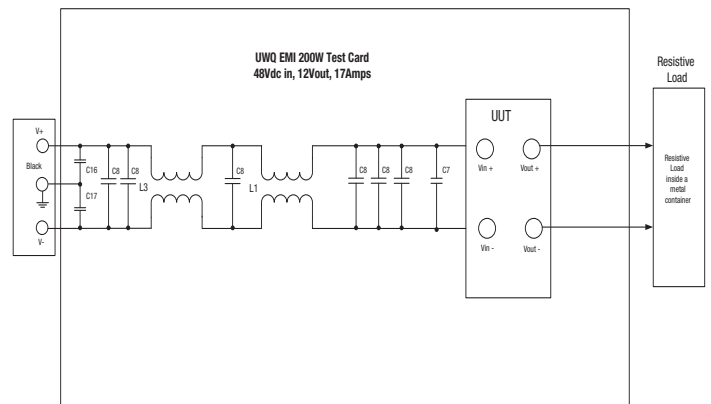

Figure 8. Conducted Emissions Test Circuit

### [1] Conducted Emissions Parts List

Reference	Part Number	Description	Vendor
L1	PE-62913	1mH, 6A	Pulse
L3	500uH,10A, MPS	500uH,10A	Murata
C8		2.2ufd	Murata
C7	VZ Series	Qty 2 - Electrolytic Capacitor 22ufd, 100V	Panasonic
C16, C17		.22ufd	Unknown

### [2] Conducted Emissions Test Equipment Used

Rohde & Schwarz EMI Test Receiver (9KHz – 1000MHz) ESPC

Rohde & Schwarz Software ESPC-1 Ver. 2.20

HP11947A Transient Limiter (Agilent)

OHMITE 25W – Resistor combinations

DC Source Programmable DC Power Supply Model 62012P-100-50

### [3] Layout Recommendations

Most applications can use the filtering which is already installed inside the converter or with the addition of the recommended external capacitors. For greater emissions suppression, consider additional filter components and/or shielding. Emissions performance will depend on the user's PC board layout, the chassis shielding environment and choice of external components. Please refer to Application Note GEAN02 for further discussion.

Since many factors affect both the amplitude and spectra of emissions, we recommend using an engineer who is experienced at emissions suppression.



Wide Input, Isolated DOSA Quarter Brick DC-DC Converters with Trim and Sense

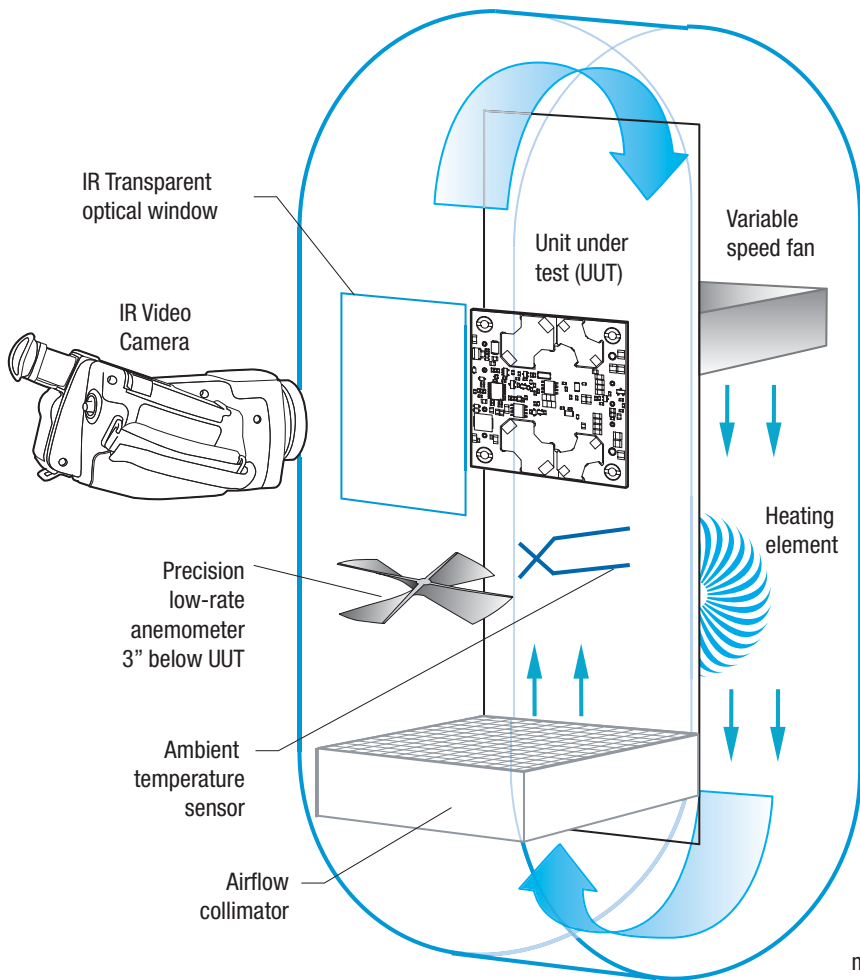

Figure 9. Vertical Wind Tunnel

### Vertical Wind Tunnel

Murata Power Solutions employs a computer controlled custom-designed closed loop vertical wind tunnel, infrared video camera system, and test instrumentation for accurate airflow and heat dissipation analysis of power products. The system includes a precision low flow-rate anemometer, variable speed fan, power supply input and load controls, temperature gauges, and adjustable heating element.

The IR camera monitors the thermal performance of the Unit Under Test (UUT) under static steady-state conditions. A special optical port is used which is transparent to infrared wavelengths.

Both through-hole and surface mount converters are soldered down to a 10" by 10" host carrier board for realistic heat absorption and spreading. Both longitudinal and transverse airflow studies are possible by rotation of this carrier board since there are often significant differences in the heat dissipation in the two airflow directions. The combination of adjustable airflow, adjustable ambient heat, and adjustable Input/Output currents and voltages mean that a very wide range of measurement conditions can be studied.

The collimator reduces the amount of turbulence adjacent to the UUT by minimizing airflow turbulence. Such turbulence influences the effective heat transfer characteristics and gives false readings. Excess turbulence removes more heat from some surfaces and less heat from others, possibly causing uneven overheating.

Both sides of the UUT are studied since there are different thermal gradients on each side. The adjustable heating element and fan, built-in temperature gauges, and no-contact IR camera mean that power supplies are tested in real-world conditions.

### Soldering Guidelines

Murata Power Solutions recommends the specifications below when installing these converters. These specifications vary depending on the solder type. Exceeding these specifications may cause damage to the product. Your production environment may differ; therefore please thoroughly review these guidelines with your process engineers.

Wave Solder Operations for through-hole mounted products (THMT)			
For Sn/Ag/Cu based solders:		For Sn/Pb based solders:	
Maximum Preheat Temperature	115° C.	Maximum Preheat Temperature	105° C.
Maximum Pot Temperature	270° C.	Maximum Pot Temperature	250° C.
Maximum Solder Dwell Time	7 seconds	Maximum Solder Dwell Time	6 seconds



Zwingenstrasse 6-8, A-2380 Perchtoldsdorf  
 Tel. Vienna +43/(0)1/86 305 - 5000  
 Fax Vienna +43/(0)1/86 305 - 98  
 e-mail: office@codico.com  
 www.codico.com

Murata Power Solutions, Inc.  
 11 Cabot Boulevard, Mansfield, MA 02048-1151 U.S.A.  
 ISO 9001 and 14001 REGISTERED



**This product is subject to the following operating requirements and the Life and Safety Critical Application Sales Policy:  
 Refer to: <http://www.murata-ps.com/requirements/>**

Murata Power Solutions, Inc. makes no representation that the use of its products in the circuits described herein, or the use of other technical information contained herein, will not infringe upon existing or future patent rights. The descriptions contained herein do not imply the granting of licenses to make, use, or sell equipment constructed in accordance therewith. Specifications are subject to change without notice. © 2013 Murata Power Solutions, Inc.