

# Stellaris® Intelligent Display Module Single-Board Computer



LUMINARY MICRO

Luminary Micro's Stellaris® Intelligent Display Module Single-Board Computer (IDM-SBC) offers a complete QVGA touch-screen user interface for control, automation, and instrumentation applications and is the first reference design featuring the powerful Tempest-class LM3S9B92 microcontroller. The IDM-SBC offers USB, Ethernet, 8 MB of SDRAM, 1 MB of serial Flash, integrated 256 KB flash, and 96 KB SRAM, and provides simplified software development for the RDK using Luminary Micro's comprehensive graphics library and ARM development tools from ARM tools partners. The 8 MB of SDRAM is connected to the LM3S9B92 microcontroller using the new External Peripheral Interface (EPI) bus available as a new feature on Tempest-class devices.

Stellaris® IDMs are the first display modules available with the efficient performance and robust integration of an ARM® Cortex™-M3 microcontroller, positioning them for use in building access controllers and security systems, intelligent white goods and home appliances, thin clients, and factory automation applications.

## Features

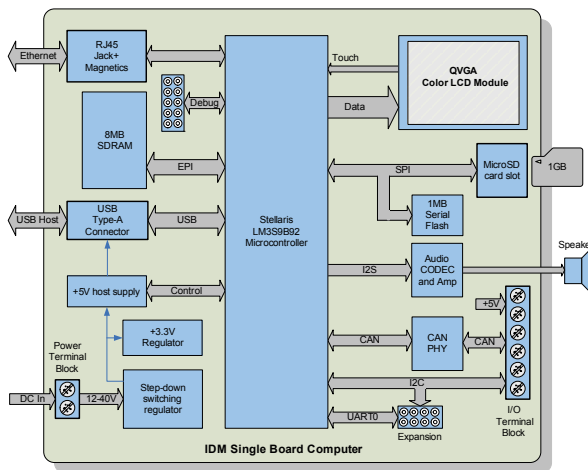

The IDM-SBC has the following features:

- Bright QVGA LCD touch-screen display
  - 262 K colors, 3.5" QVGA 320 x 240 pixels
  - White LED backlight with resistive touch panel
- Serial connectivity options
  - USB 2.0 Host
  - 10/100 Ethernet MAC and PHY
- 1 MBPS Controller Area Network (CAN)
- I<sup>2</sup>C Interface for external peripherals and sensors
- UART serial port with TTL signal levels
- High-performance microcontroller
  - 32-bit ARM® Cortex™-M3 core

- 256 KB single-cycle Flash, 96 KB single-cycle SRAM, and 80 MHz operation
- Versatile board-level memories
  - 8 MB SDRAM connected by EPI
  - 1 MB serial flash connected by SPI
  - microSD card slot
  - USB Host connector for external mass-storage devices
- Power supply
  - Wide input range 12-40 Vdc power supply with auxiliary 5 V power output
- I<sup>2</sup>S mono Codec for high-quality audio with 0.8 W amplifier for external 8-Ohm speaker
- Screw terminal block for I<sup>2</sup>C, CAN, and power connections
- Compact 2.0" x 3.0" PCB footprint
- Easy to customize
  - Includes full source code, example applications, and design files
  - Develop using tools supporting the IDM-SBC from Keil, IAR, Code Sourcery, and Code Red (using a Stellaris evaluation kit or preferred ARM Cortex-M3 debugger)
  - Supported by Luminary Micro Graphics Library and StellarisWare™ Peripheral Driver Library
    - Comes with factory-programmed quickstart game demo application
    - Ethernet boot loader for firmware update

## Reference Design Kit



The Stellaris® IDM-SBC is offered as a complete open-tool reference design kit (RDK-IDM-SBC) and ships with everything needed to quickly evaluate the IDM-SBC including:

- Stellaris® IDM-SBC board
- MDL-ADA2 10-pin to 20-pin adapter
- USB flash drive (128 MB)
- 24 V power supply with international plug-set



# Stellaris® Intelligent Display Module Single-Board Computer (continued)

LUMINARY MICRO

- Ethernet cable
- 8 Ohm speaker
- CD with tools, documentation and source code including: Quickstart Guide, User's Manual, Software Reference Manual, Board Data Sheet, BOM, schematics, and Gerber files

## Ordering Information

Product Number	Description
RDK-IDM-SBC	Stellaris® Intelligent Display Module Single-Board Computer Reference Design Kit (RDK)

Luminary Micro, Inc. • 108 Wild Basin, Suite 350 • Austin, TX 78746  
Main: +1-512-279-8800 • Fax: +1-512-279-8879 • <http://www.luminarymicro.com> • [sales@luminarymicro.com](mailto:sales@luminarymicro.com)

*Copyright © 2009 Luminary Micro, Inc. All rights reserved. Stellaris, Luminary Micro, and the Luminary Micro logo are registered trademarks, and StellarisWare is a trademark of Luminary Micro, Inc. or its subsidiaries in the United States and other countries. ARM and Thumb are registered trademarks, and Cortex is a trademark of ARM Limited. Other names and brands may be claimed as the property of others.*