

GENERAL DESCRIPTION

The XRT83VSH316 is a fully integrated 16-channel short-haul line interface unit (LIU) that operates from a 1.8V Inner Core and 3.3V I/O power supplies. Using internal termination, the LIU provides one bill of materials to operate in T1, E1, or J1 mode independently on a per channel basis with minimum external components. The LIU features are programmed through a standard parallel microprocessor interface or SPI (Serial Mode). EXAR's LIU has patented high impedance circuits that allow the transmitter outputs and receiver inputs to be high impedance when experiencing a power failure or when the LIU is powered off. Key design features within the LIU optimize 1:1 or 1+1 redundancy and non-intrusive monitoring applications to ensure reliability without using relays.

The on-chip clock synthesizer generates T1/E1/J1 clock rates from a selectable external clock frequency and has five output clock references that can be used

for external timing (8kHz, 1.544Mhz, 2.048Mhz, nXT1/J1, nxE1).

Additional features include System Side LOS, AIS, QRSS/PRBS and Line Side RLOS, AIS, QRSS/PRBS, DMO with 16-bit LCV counters and diagnostic loopback modes for each channel.

APPLICATIONS

- T1 Digital Cross Connects (DSX-1)
- ISDN Primary Rate Interface
- CSU/DSU E1/T1/J1 Interface
- T1/E1/J1 LAN/WAN Routers
- Public Switching Systems and PBX Interfaces
- T1/E1/J1 Multiplexer and Channel Banks
- Integrated Multi-Service Access Platforms (IMAPs)
- Integrated Access Devices (IADs)
- Inverse Multiplexing for ATM (IMA)
- Wireless Base Stations

FIGURE 1. BLOCK DIAGRAM OF THE XRT83VSH316

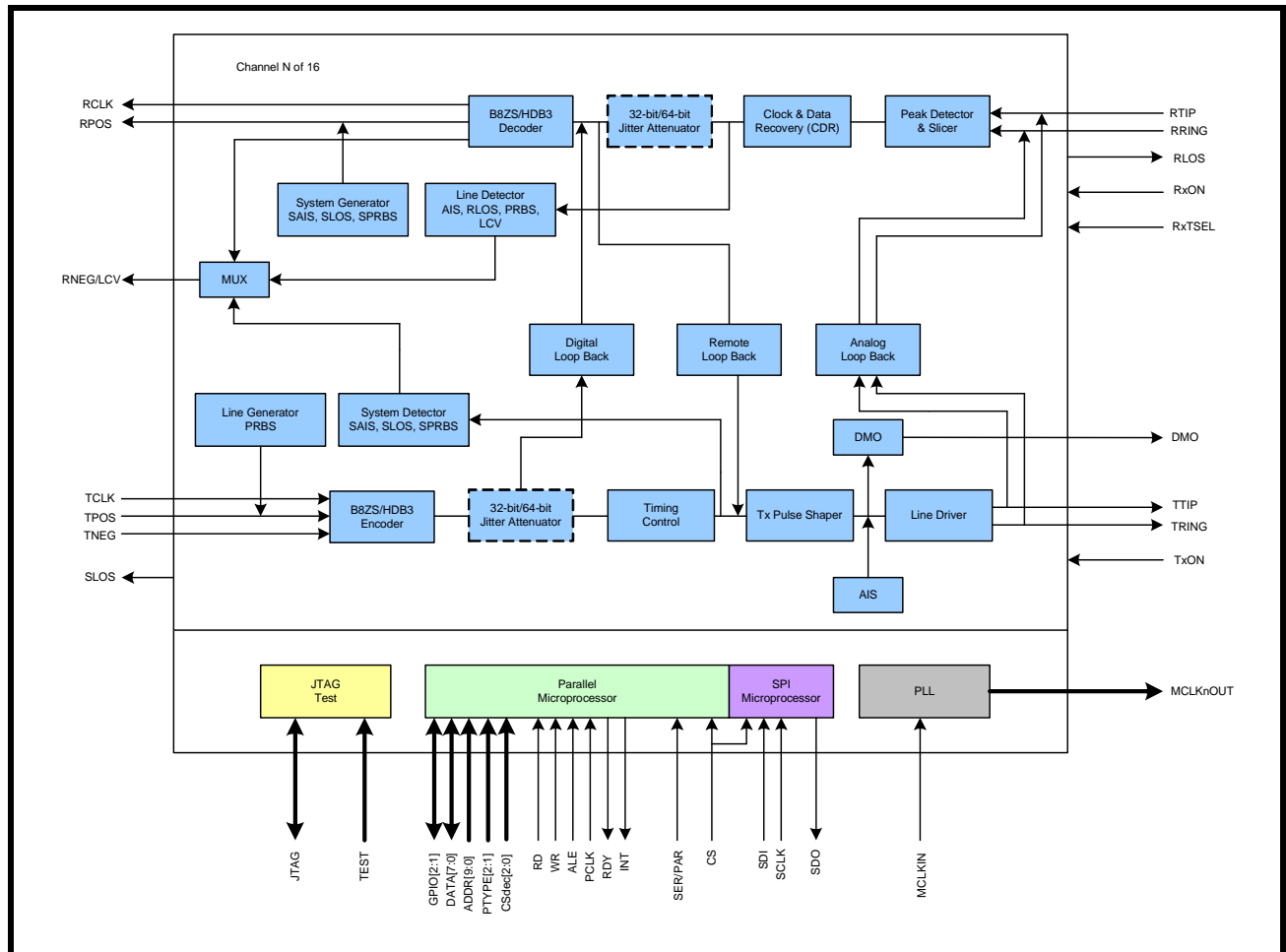

16-CHANNEL T1/E1/J1 SHORT-HAUL LINE INTERFACE UNIT**FEATURES**

- Fully integrated 16-Channel short haul transceivers for T1/J1 (1.544MHz) and E1 (2.048MHz) applications
- Parallel or SPI Microprocessor Interface
- T1/E1/J1 short haul and clock rate are per port selectable through software without changing components
- Internal Impedance matching on both receive and transmit for 75Ω (E1), 100Ω (T1), 110Ω (J1), and 120Ω (E1) applications are per port selectable through software without changing components
- Power down on a per channel basis with independent receive and transmit selection
- Five pre-programmed transmit pulse settings for T1 short haul applications per channel
- User programmable Arbitrary Pulse mode for T1 and E1
- On-Chip transmit short-circuit protection and limiting protects line drivers from damage on a per channel basis
- Crystal-Less digital jitter attenuators (JA) with 32-Bit or 64-Bit FIFO for the receive or transmit path per channel
- Driver failure monitor output (DMO) alerts of possible system or external component problems
- Transmit outputs and receive inputs may be "High" impedance for protection or redundancy applications on a per channel basis
- Support for automatic protection switching
- 1:1 and 1+1 protection without relays
- Receive monitor mode handles 0 to 6dB resistive attenuation (flat loss) along with 0 to 6dB cable loss for both T1 and E1
- Loss of signal (LOS) according to ITU-T G.775/ETS300233 (E1) and ANSI T1.403 (T1/J1) for system (SLOS) and line (RLOS) side diagnostics
- Programmable data stream muting upon RLOS detection
- On-Chip HDB3/B8ZS encoder/decoder with an internal 16-bit LCV counter for each channel
- On-Chip digital clock recovery circuit for high input jitter tolerance
- QRSS/PRBS pattern generator and detection for testing and monitoring for system (SPRBS) and line (PRBS) side diagnostics
- Error and bipolar violation insertion and detection
- Transmit all ones (TAOS) Generators and Detectors for system (SAIS) and line (AIS) side diagnostics
- Supports local analog, remote, digital, and dual loopback modes
- Supports gapped clocks for mapper/multiplexer applications
- 1.8V Digital Core
- 3.3V I/O and Analog Core
- 316-Pin STBGA package
- -40°C to +85°C Temperature Range

PRODUCT ORDERING INFORMATION

PRODUCT NUMBER	PACKAGE TYPE	OPERATING TEMPERATURE RANGE
XRT83VSH316IB	316 Shrink Thin Ball Grid Array (21.0 mm x 21.0 mm, STBGA)	-40°C to +85°C

Your contact: www.codico.com mailto: office@codico.com phone: +43/1/86305-0 fax: +43/1/86305-98