

# J202H-I

Wi-Fi Single-band 1X1 802.11b/g/n

IoT Module Datasheet



## J202H-I Serial

### Module Datasheet

**Office:** 6 Floor, Building U6, Junxiang U8 Park,  
Hangcheng Avenue, Bao'an District,  
Shenzhen City, CHINA

**Factory:** No.8, Litong Road, Liuyang Economic & Technical  
Development Zone, Changsha, Hunan, CHINA

**TEL:** +86-755-2955-8186

**Website:** [www.fn-link.com](http://www.fn-link.com)

Customer Approval : \_\_\_\_\_ Company  
\_\_\_\_\_  
Title  
\_\_\_\_\_  
Signature  
\_\_\_\_\_  
Date  
\_\_\_\_\_  
Fn-Link

## Revision History

Version	Date	Revision Content	Draft	Approved
1.0	2021/06/17	Initial release	Tzq	Qjp
2.0	2021/08/10	Update the picture	Tzq	Qjp

## CONTENTS

<b>1 Overview.....</b>	<b>1</b>
1.1 Introduction.....	1
1.2 Features.....	1
1.3 General Specification.....	3
1.4 Operating Conditions.....	3
<b>2 Wi-Fi RF Specification.....</b>	<b>4</b>
2.1 2.4GHz RF Specification.....	4
<b>3 Power Consumption.....</b>	<b>5</b>
<b>4 Pin Assignments.....</b>	<b>5</b>
4.1 Pin outline.....	5
4.2 Pin Definition.....	7
4.3 Pin Function Group Table.....	8
<b>5 Dimensions.....</b>	<b>9</b>
5.1 Module Picture.....	9
5.2 Physical Dimensions.....	10
5.3 Layout Recommendation.....	10
5.4 RF connector for external antenna.....	11
<b>6 Reference Design.....</b>	<b>11</b>
6.1 Schematic reference design.....	11
6.2 Antenna clearance area requirements.....	12
<b>7 Ordering Information.....</b>	<b>13</b>
<b>8 The Key Material List.....</b>	<b>13</b>
<b>9 Recommended Reflow Profile.....</b>	<b>13</b>
<b>10 Package Information.....</b>	<b>15</b>
10.1 Reel.....	15
10.2 Carrier Tape Detail.....	15
10.3 Packaging Detail.....	16
10.4 Moisture Sensitivity.....	17

# 1 Overview

## 1.1 Introduction

J202H-I is a Wi-Fi + BLE combination module for low power consumption and high performance application development. The wireless subsystem includes 2.4G radio, Wi-Fi 802.11b/ G /n and BLE 5.0 baseband /MAC designs. The microcontroller subsystem contains a low-power 32-bit RISC CPU, cache, and memory. The power source management unit controls the low power mode. In addition, various security features are supported.

Peripheral interfaces include SDIO, SPI, UART, I2C, IR Remote, PWM, ADC, DAC, PIR and GPIO.

## 1.2 Features

### Wi-Fi General

- supports IEEE 802.11b /g/n protocol
- 2.4GHz band 1T1R mode, support 20 MHz, data rate up to 72.2Mbps
- Wi-Fi Security WPS/WEP/WPA/WPA2 Personal/WPA2 Enterprise/WPA3
- Support Station mode, Softap mode, Station + Softap mode, Sniffer mode
- Bluetooth low energy consumption 5.0, Bluetooth Mesh
- Wi-Fi and BLE coexist
- 5.0 support BLE

### MCU Features

- 32-bit RISC CPU with FPU
- 1 RTC timer with a maximum counting cycle of 1 year
- DFS from 1MHz to 192MHz
- Support XIP QSPI Flash startup, built-in image decryption unit

### Host Interface

- SDIO 2.0 1x
- SPI 1x
- I2C 1x
- UART 3x
- I2S 1x
- PWM 5x
- ADC 5x
- GPIO 13x

**Note:** Please refer to chapter 4.3 pin function table for detail host interface configures

The general block diagram of the module is shown as below

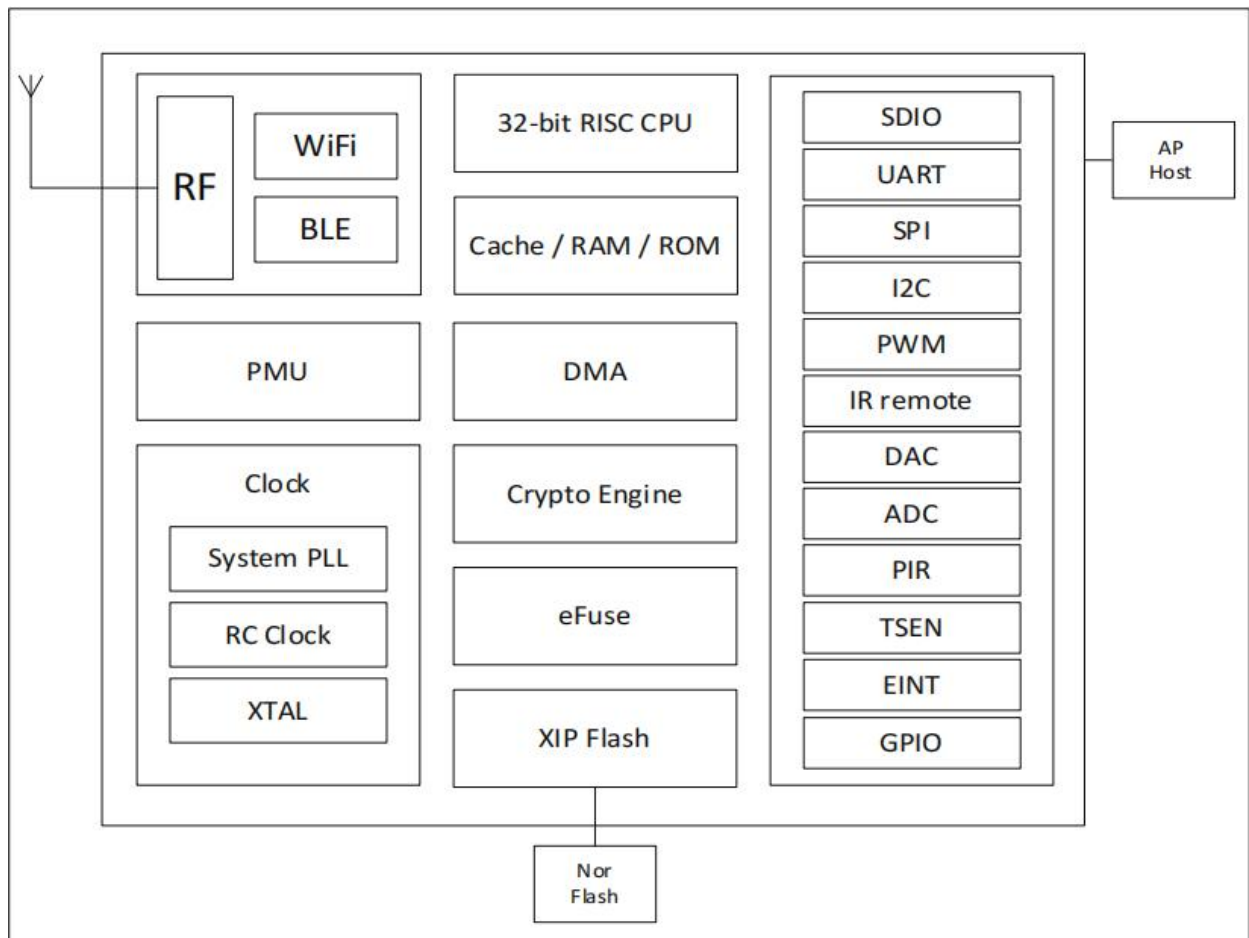

Figure 1-1 Block Diagram

### 1.3 General Specification

Model Name	J202H-I
Main Chipset	BL602C-20-Q2I(J202H-I)
Host Interface	SDIO, SPI, I2C, UART, I2S, PWM, ADC, GPIO
Wi-Fi Standards	802.11b/g/n
Dimension	L x W x H: 18.00mm*20.00mm*2.45mm
RoHS	All hardware components are fully compliant with EU RoHS directive

### 1.4 Operating Conditions

Operating Voltage	3.3±10% Vdc
Operating Temperature	-10°C to +85°C
Storage Temperature	-40°C to +85°C

## 2 Wi-Fi RF Specification

### 2.1 2.4GHz RF Specification

Feature	Description			
WLAN Standard	IEEE 802.11 b/g/n Wi-Fi compliant			
Frequency Range	2.412~2.472GHz			
Number of Channels	<b>Wi-Fi:</b> USA/Canada: channel 1~11; Europe/China/Australia: channel 1~13			
Spectrum Mask	Min. b/g/n	Typ. b/g/n	Max. b/g/n	Unit b/g/n
1st side lobes(to fc ± 11MHZ)	-	-43/-30/-40	-	dBr
2st side lobes(to fc ± 22MHZ)	-	-52/-33/-58	-	dBr
Freq. Tolerance	-20/-20/-20	-	20/20/20	ppm
Test Items	Typical Value			EVM
Output Power	802.11b /11Mbps : 17dBm ± 2 dB			EVM ≤ -10dB
	802.11g /54Mbps : 15dBm ± 2 dB			EVM ≤ -25dB
	802.11n /MCS7 : 14dBm ± 2 dB			EVM ≤ -28dB
Test Items	Test Value			Standard Value
SISO Receive Sensitivity (11b,20MHz) @8% PER	-	1Mbps	PER @ -94 dBm	≤-83 dBm
	-	2Mbps	PER @ -92 dBm	≤-80 dBm
	-	5.5Mbps	PER @ -89 dBm	≤-79 dBm
	-	11Mbps	PER @ -87 dBm	≤-76 dBm
SISO Receive Sensitivity (11g,20MHz) @10% PER	-	6Mbps	PER @ -89 dBm	≤-85 dBm
	-	9Mbps	PER @ -88 dBm	≤-84 dBm
	-	12Mbps	PER @ -87 dBm	≤-82 dBm
	-	18Mbps	PER @ -86 dBm	≤-80 dBm
	-	24Mbps	PER @ -84 dBm	≤-77 dBm
	-	36Mbps	PER @ -80 dBm	≤-73 dBm
	-	48Mbps	PER @ -77 dBm	≤-69 dBm
SISO Receive Sensitivity (11n,20MHz) @10% PER	-	54Mbps	PER @ -74 dBm	≤-68 dBm
	-	MCS=0	PER @ -89 dBm	≤-85 dBm
	-	MCS=1	PER @ -86 dBm	≤-82 dBm
	-	MCS=2	PER @ -84 dBm	≤-80 dBm
	-	MCS=3	PER @ -82 dBm	≤-77 dBm
-	MCS=4	PER @ -79 dBm	≤-73 dBm	



	- MCS=5 PER @ -76 dBm	≤-69 dBm
	- MCS=6 PER @ -74 dBm	≤-68 dBm
	- MCS=7 PER @ -71 dBm	≤-67 dBm
Maximum Input Level	802.11b: -10 dBm	
	802.11g/n: -20 dBm	
Antenna Reference	PCB antenna with 0~2 dBi peak gain; External	

### 3 Power Consumption

Test mode	Current Value @3.3Vdc
TX	11M 138mA
	54M 143mA
	11n-MCS7 144mA
	BLE 1M@15dBm 133mA
RX	11M 73mA
	54M 77mA
	11n-MCS7 77mA

### 4 Pin Assignments

#### 4.1 Pin outline

< TOP VIEW >

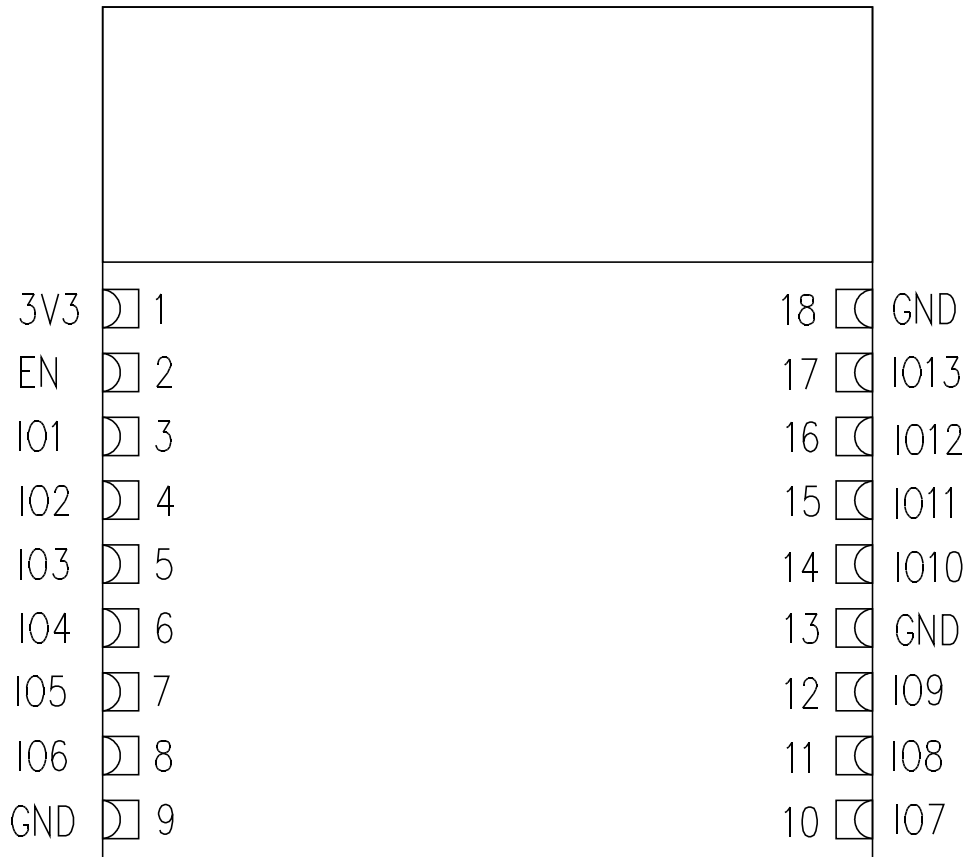

Figure 4-1 Pin Outline

## 4.2 Pin Definition

Pin#	Name	Type	Description	Voltage
1	3V3	P	3.3Vdc Power input	3.3V
2	EN	I	Enable chip. 1: Enable Chip, 0: Shut Down Chip. Default pull high	3.3V
3	IO1		GPIO Pin. The MUX Function can be referred to Pin Function Table	
4	IO2		GPIO Pin. The MUX Function can be referred to Pin Function Table	
5	IO3		GPIO Pin. The MUX Function can be referred to Pin Function Table	
6	IO4		GPIO Pin. The MUX Function can be referred to Pin Function Table	
7	IO5		GPIO Pin. The MUX Function can be referred to Pin Function Table	
8	IO6		GPIO Pin. The MUX Function can be referred to Pin Function Table	
9	GND		Ground connections	
10	IO7		GPIO Pin. The MUX Function can be referred to Pin Function Table	
11	IO8		Boot strap selection.Pin state sampled on rising edge of CHIP_EN. High: Boot from interface. Low: Boot from flash.	
12	IO9		GPIO Pin. The MUX Function can be referred to Pin Function Table	
13	GND		Ground connections	
14	IO10		GPIO Pin. The MUX Function can be referred to Pin Function Table	
15	IO11		GPIO Pin. Chip Jtag TDO pin, Not recommended	
16	IO12		GPIO Pin. The MUX Function can be referred to Pin Function Table	
17	IO13		GPIO Pin. The MUX Function can be referred to Pin Function Table	

18	GND		Ground connections	
----	-----	--	--------------------	--

P: POWER I:INPUT O: OUTPUT

### 4.3 Pin Function Group Table

PIN		SDIO	SPI	UART0	UART2	I2C	PWM	ADC	JTAG
3	GPIO1	CMD	MOSIO/MII		UART0_CTS	SDA	PWM_CH1		TDI/TDO
4	GPIO0	CLK	MOSI /MISO		UART0_RTS	SCL	PWM_CH0		TMS/TCK
5	GPIO3	DAT1	SCLK		UART0_RXD	SDA	PWM_CH3		TDO/TDI
6	GPIO20		MOSI /MISO		UART1_RTS	SCL	PWM_CH0		TMS/TCK
7	GPIO16		MOSI /MISO	UART_TXD		SCL	PWM_CH1		TMS/TCK
8	GPIO7		SCLK	UART_RXD		SDA	PWM_CH2		TDO/TDI
10	GPIO4	DAT2	MOSI /MISO		UART1_RTS	SCL	PWM_CH4	ADC_CH1	TMS/TCK
11	GPIO12		MOSI /MISO		UART1_RTS	SCL	PWM_CH2	ADC_CH0	TMS/TCK
12	GPIO21		MOSIO/MII		UART1_CTS	SDA	PWM_CH1		TDI/TDO
14	GPIO14		SS		UART1_TXD	SCL	PWM_CH4	ADC_CH2 /DAC_B	TCK/TMS
15	GPIO5	DAT3	MISO /MOSI		UART1_CTS	SDA	PWM_CH0	ADC_CH4	TDI/TDO
16	GPIO8		MOSI /MISO		UART1_CTS	SDA	PWM_CH0	ADC_CH4	TDI/TDO
17	GPIO2	DAT0	SS		UART0_TXD	SCL	PWM_CH2		TCK/TMS

Note:

1, Pin7 is default configured as UART0\_LOG\_TXD, Pin8 is default configured as UART0\_LOG\_RXD, UART0 is used for firmware burning and print the booting log.

2, Pin11 is default configured as UART2\_RXD, Pin12 is default configured as UART2\_TXD, UART2 is used for AT communication, default baud rate is 115200.

## 5 Dimensions

### 5.1 Module Picture

L x W: 18 x 20 (+0.3/-0.1) mm

On board PCB antenna:

FGJ202HIXX-00

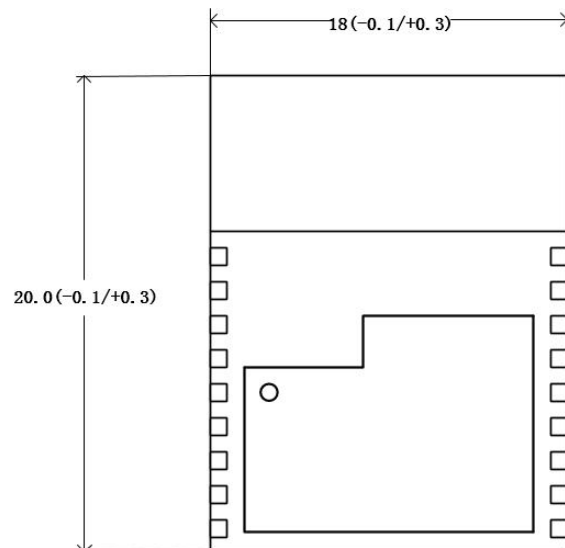
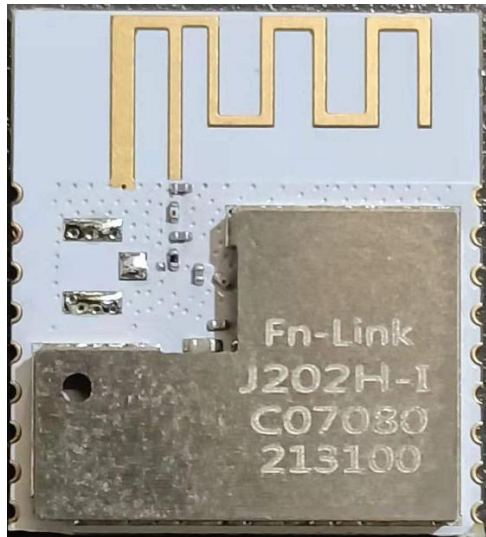

H: 2.45 (±0.10) mm

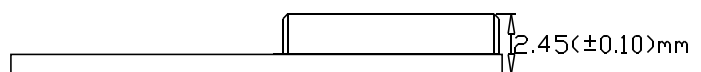

**Weight**

**TDB**

## 5.2 Physical Dimensions

(unit: mm)

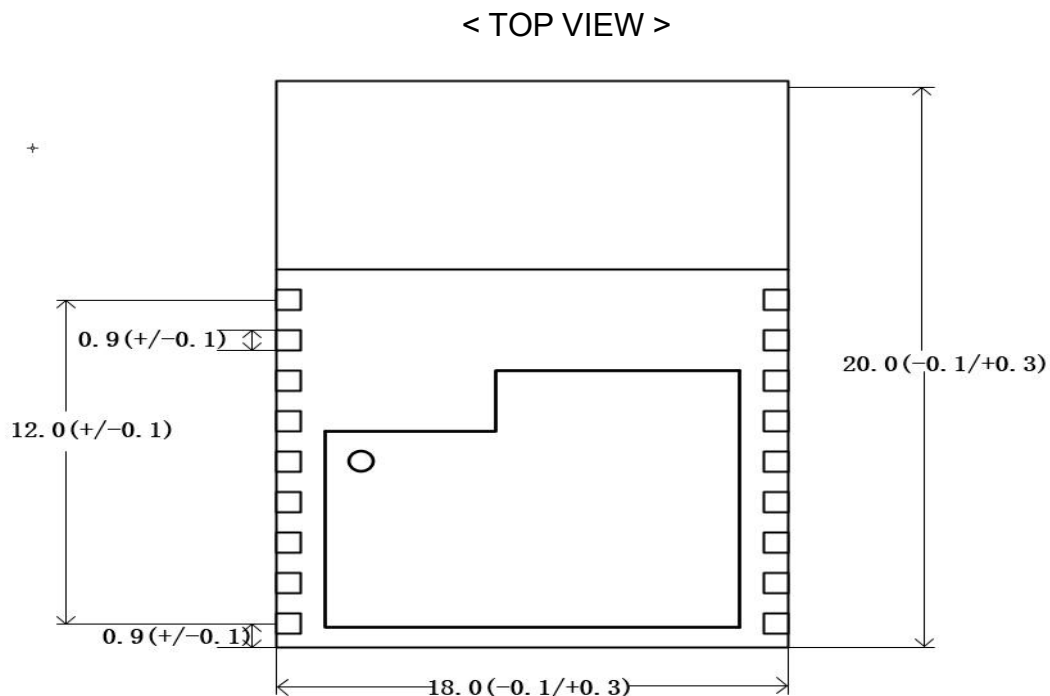

Figure 5-1 Physical Dimensions

## 5.3 Layout Recommendation

(unit: mm)

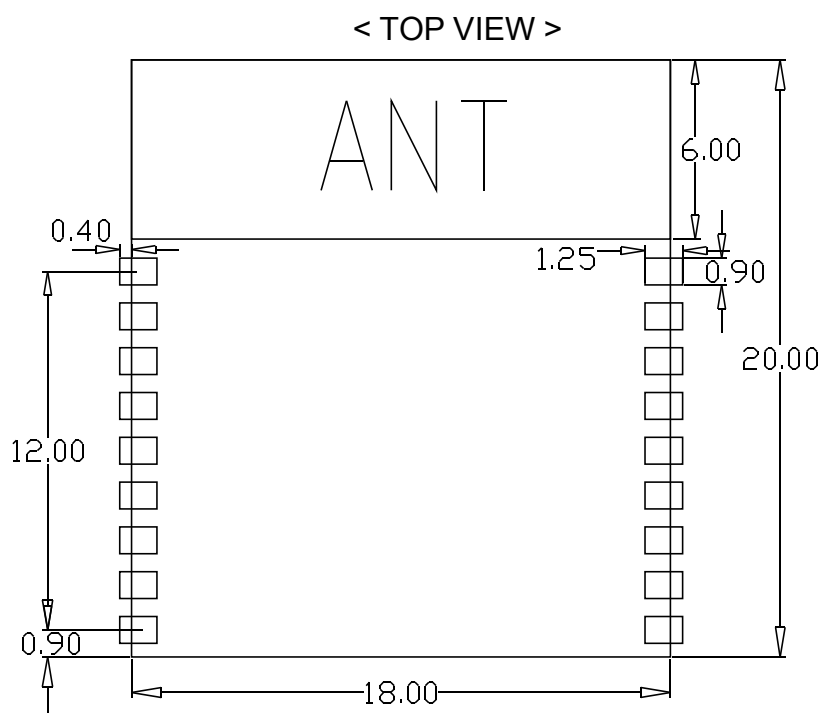

Figure 5-2 Layout recommendation

## 5.4 RF connector for external antenna

Unit:mm

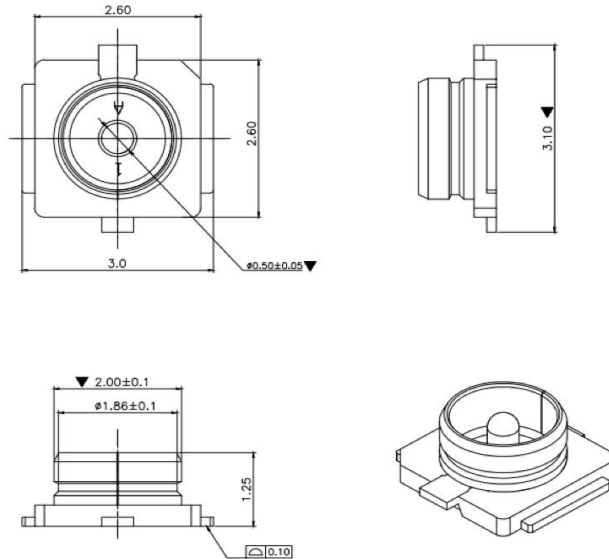

Figure 5-3 RF connector for external antenna

## 6 Reference Design

### 6.1 Schematic reference design

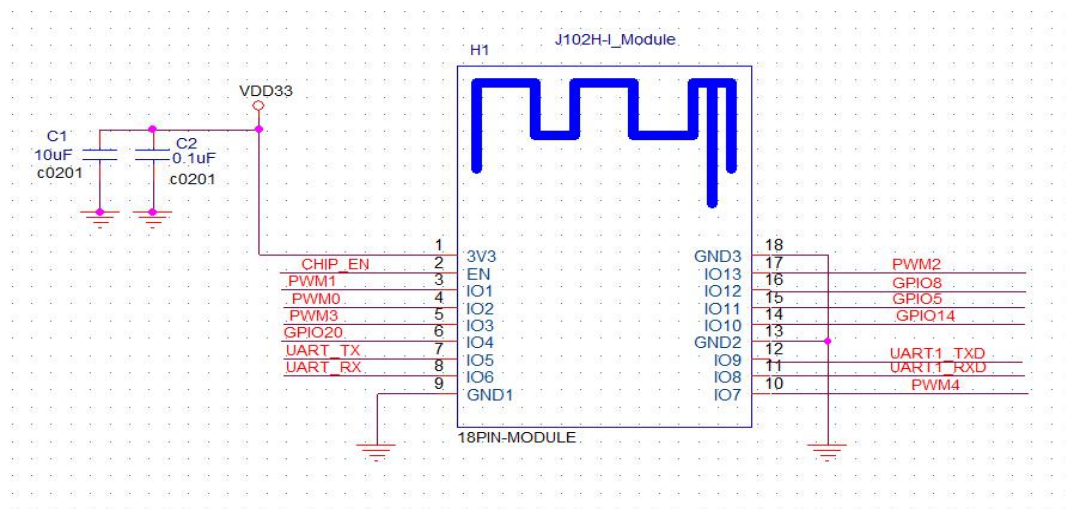

Figure 6-1 Reference Schematic

**Note:**

Please place C1,C2 close to PIN 1.

It is recommended have power supply current greater than 500mA for the module.



PIN16 GPIO8 Do not pull this pin up

## 6.2 Antenna clearance area requirements

When using PCB antenna on Wi-Fi module, make sure the distance between PCB on motherboard and other metal devices is at least 16mm. The shaded areas in the figure below need to be marked away from metal devices, sensors, interference sources, and other materials that may interfere with the signal.

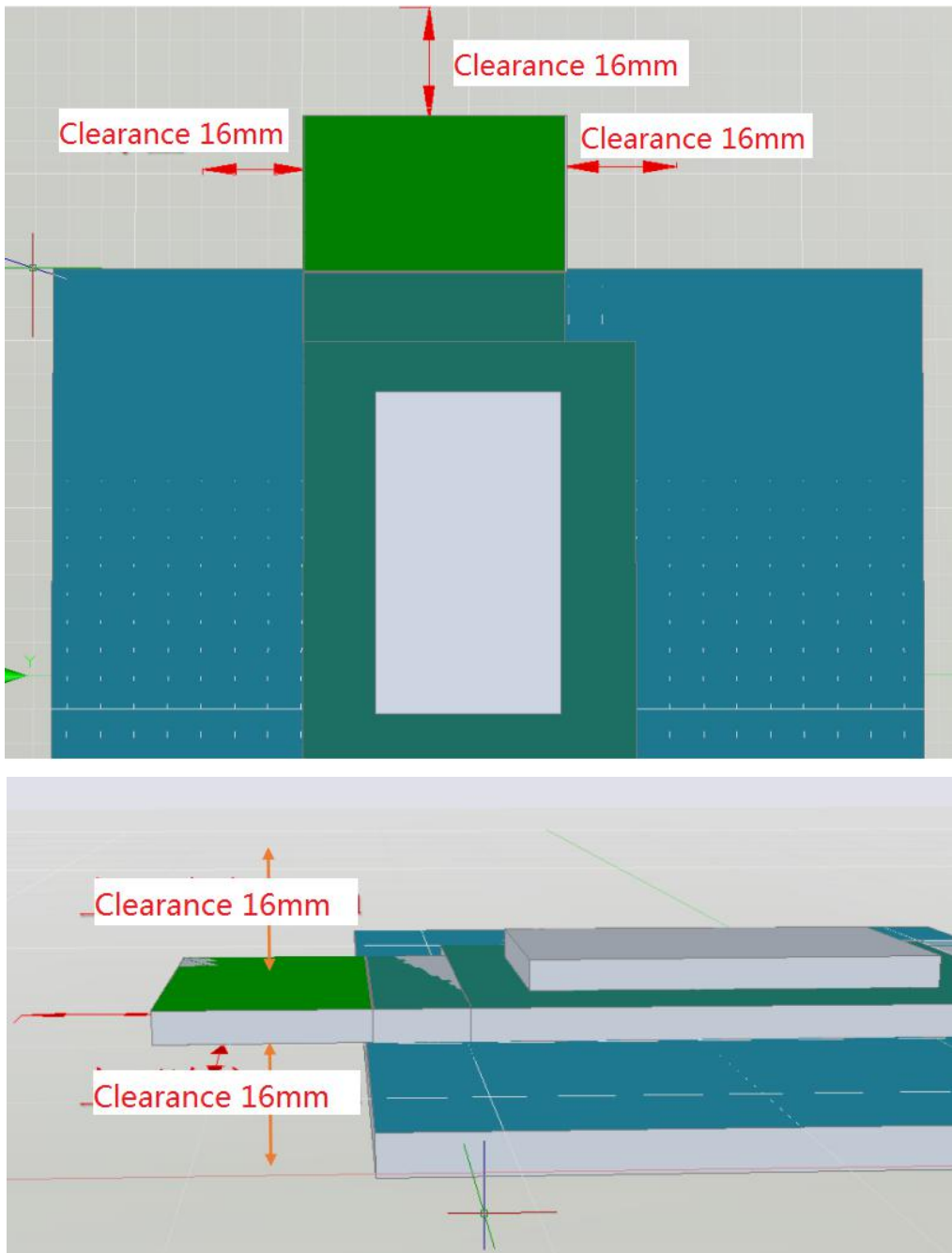

Figure 6-2 Antenna clearance reference

## 7 Ordering Information

Part NO.	Description
FGJ202HIXX-00	BL602C-20-Q2I, 802.11b/g/n, 1T1R, UART/GPIO/I2C/PWM/SPI/SDIO/I2S, PCB ANT, 18*20mm, PCB V1.0

## 8 The Key Material List

Item	Part Name	Description	Manufacturer
1	Crystal	3225 40MHz 10ppm	ECEC, TKD, Hosonic, JWT, TXC
2	Chipset	BL602C-20-Q2I	博流
3	PCB	FR4, 2 LAYER, GREEN	XY-PCB, GDKX, Sunlord, SLPCB

## 9 Recommended Reflow Profile

Refer to IPC/JEDEC standard.

Peak Temperature: <250°C

Number of Times: ≤2 times

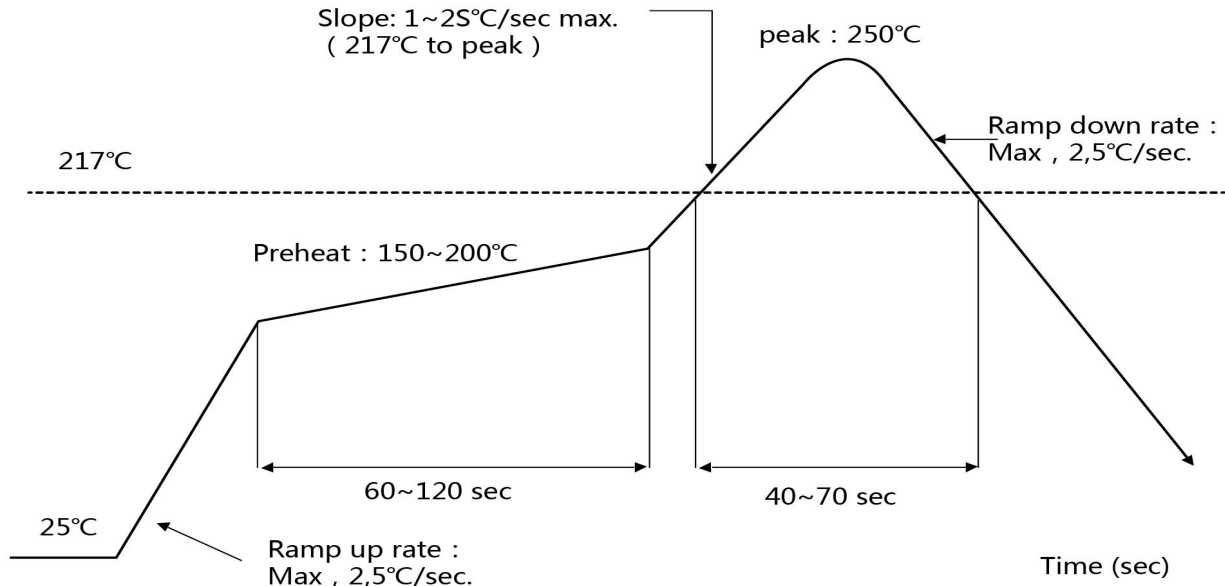

Figure 9-1 Reference reflow profile

## 10 Package Information

### 10.1 Reel

A roll of 800pcs

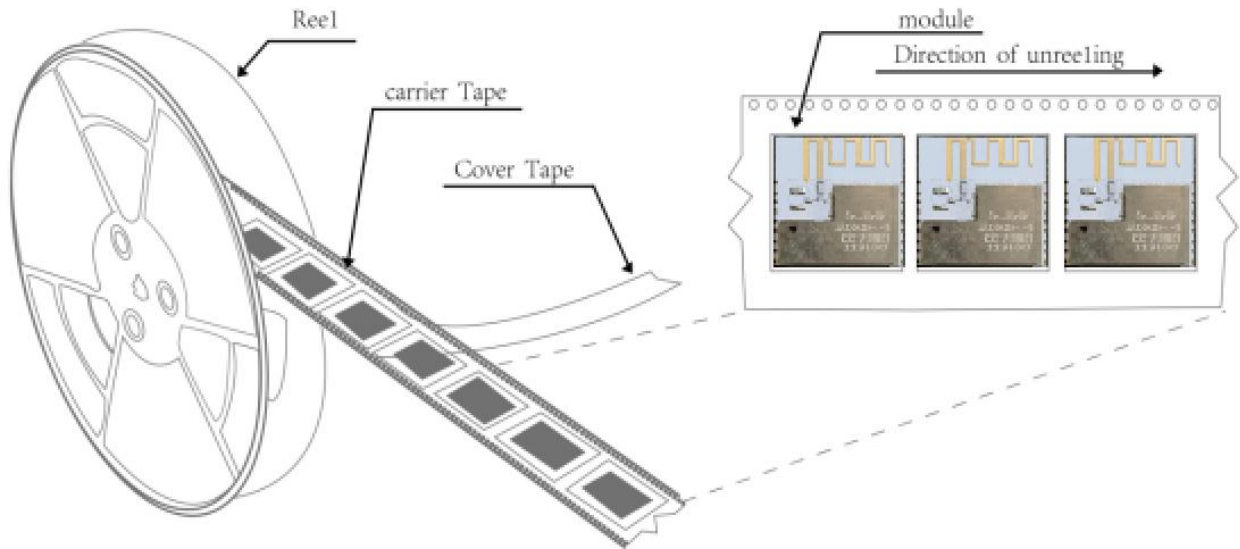

Figure 10-1 Package reel Reference

### 10.2 Carrier Tape Detail

ITEM	W	A0	B0	D	E	F	F1	K0	P0	P2	P	T
DIM	32	18.40	20.30	1.5	1.75	14.20	28.4	3.50	4.0	2.0	24.0	0.30
TOLE	$\begin{matrix} +0.3 \\ -0.3 \end{matrix}$	$\pm 0.15$	$\pm 0.15$	$\begin{matrix} +0.1 \\ -0.0 \end{matrix}$	$\pm 0.1$	$\pm 0.15$	$\pm 0.10$	$\pm 0.10$	$\pm 0.1$	$\pm 0.15$	$\pm 0.1$	$\pm 0.05$

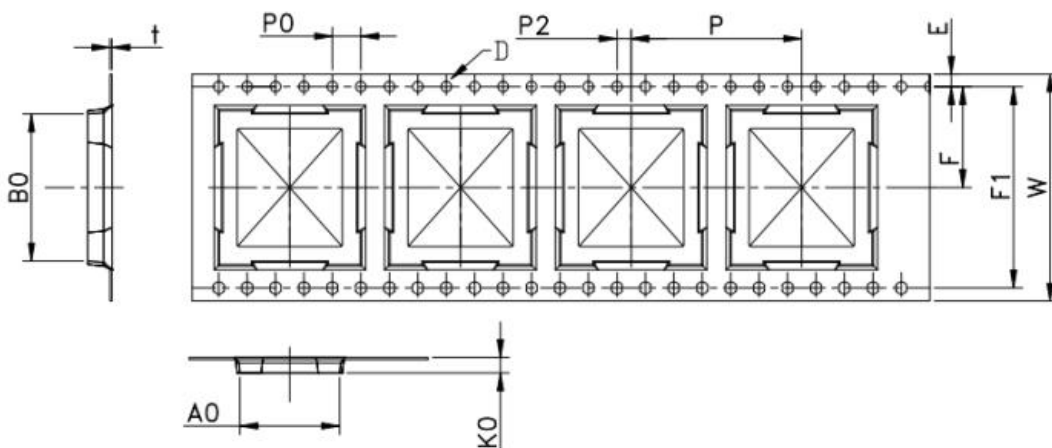

Figure 10-2 Carrier tape detail

### 10.3 Packaging Detail

the take-up package



Using self-adhesive tape

Size of black tape:44mm\*20.2m      the cover tape :37.5mm\*20.2m

Color of plastic disc: blue

A roll of 800pcs



NY bag size:415mm\*450mm

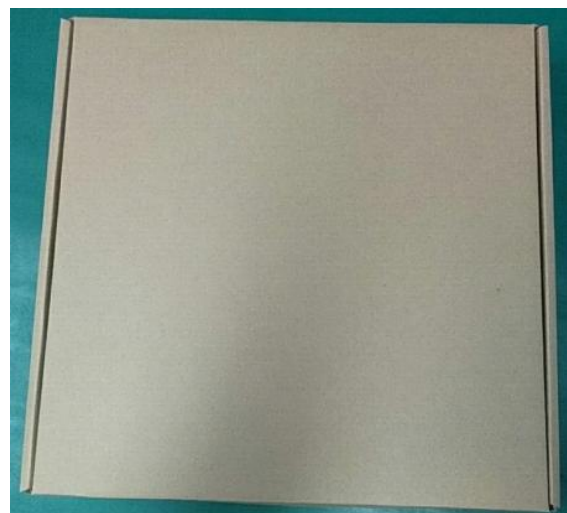

size : 350X350X35mm



The packing case size: 360X210X370mm

## 10.4 Moisture Sensitivity

The Modules is a Moisture Sensitive Device level 3, in according with standard IPC/JEDEC J-STD-020, take care all the relatives requirements for using this kind of components.

Moreover, the customer has to take care of the following conditions:

- a) Calculated shelf life in sealed bag: 12 months at <math><40^{\circ}\text{C}</math> and <math><90\%</math> relative humidity (RH)
- b) Environmental condition during the production: - c) The maximum time between the opening of the sealed bag and the reflow process must be 168 hours if condition
- d) "IPC/JEDEC J-STD-033A paragraph 5.2" is respected
- e) Baking is required if conditions b) or c) are not respected
- f) Baking is required if the humidity indicator inside the bag indicates 10% RH or more