

Click to
ORDER
samples

AM3GU-JZ

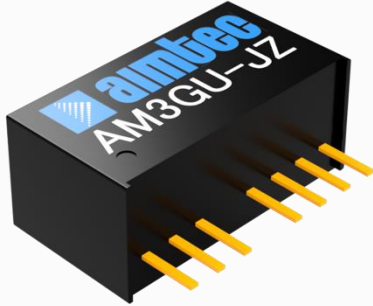

SIP 8

Aimtec introduces the AM3GU-JZ series of DC/DC converters, which are Aimtec's first 8:1 ultra-wide input voltage range products. The impressive 4.5-36VDC input voltage can help power applications with widely varying inputs. These converters can also help reduce the total BOM by replacing multiple DC/DC converters with different narrower input voltage ranges with one cost-effective isolated DC-DC solution.

With 5, 12, 15, ± 5, ± 12, ± 15VDC output voltage options, the AM3DU are well suited for industrial and commercial applications. These products have an impressive operating temperature range of -40°C to 105°C with full power up to 75°C. They also feature isolation of 3000VDC and a high MTBF of 1,000,000h for improved reliability and system safety. Features such as output short circuit protection (OSCP), output over-current protection (OCP), and input under-voltage protection (UVLO) come standard with this family of products.

The AM3GU-JZ series are ideal for battery operated circuits, IoT, analog circuits, grid power, LED, instrumentation, industrial controls, communication, and civil applications.

Features

- Ultra-wide 8:1 Input Range: 4.5VDC – 36VDC
- Operating Temp: -40 °C to +105 °C
- Low ripple & noise, up to 100mV(p-p) max
- Efficiency up to 79%
- Output short circuit, over current protection, Input under-voltage protection
- Regulated Output
- No load power consumption low to 0.12W



Summary

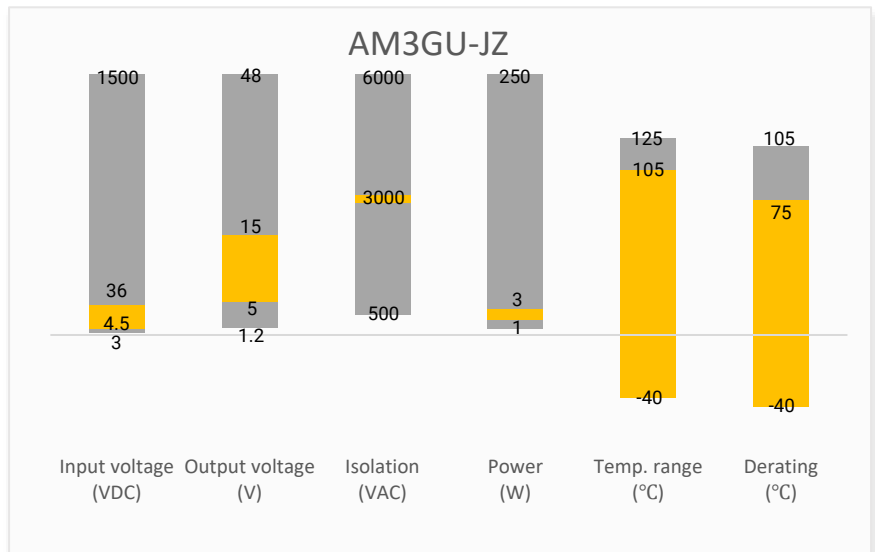

Training



Product Training Video
(click to open)



Press Release

Coming Soon!

Application Notes

Applications



Power Grid



Industrial



Telecom



Instrumentation

Models & Specifications

Single Output

Model	Input Voltage (VDC)	Output Voltage (VDC)	Input Current Max (mA)		Output Current Max (mA)	Maximum Capacitive Load (μF)	Efficiency (%) Full Load
			No Load	Full Load			
AM3GU-1205SH30JZ	12 (4.5 ~ 36)	5	16	334	600	1000	77
AM3GU-1212SH30JZ	12 (4.5 ~ 36)	12	16	325	250	330	79
AM3GU-1215SH30JZ	12 (4.5 ~ 36)	15	16	325	200	220	79

Dual Output

Model	Input Voltage (VDC)	Output Voltage (VDC)	Input Current Max (mA)		Output Current Max (mA)	Maximum Capacitive Load (μF)	Efficiency (%) Full Load
			No Load	Full Load			
AM3GU-1205DH30JZ	12 (4.5 ~ 36)	± 5	16	334	± 300	± 470	77
AM3GU-1212DH30JZ	12 (4.5 ~ 36)	± 12	16	325	± 125	± 220	79
AM3GU-1215DH30JZ	12 (4.5 ~ 36)	± 15	16	325	± 100	± 100	79

Input Specification

Parameters	Conditions	Typical	Maximum	Units
Voltage range	See models table			VDC
Filter	Capacitance filter			
Absolute maximum rating	1 sec. max		50	VDC
Reflected ripple current		50		mA pk-pk
Start-up voltage			4.5	VDC
Under voltage protection		3.5		VDC

Isolation Specification

Parameters	Conditions	Typical	Maximum	Units
Tested I/O voltage	60 sec, 1mA max	> 3000		VDC
Resistance	I/O resistance at 500VDC	> 1000		MΩ
Capacitance	I/O capacitance at 100KHz/0.1V	40		pF

Output Specification

Parameters	Conditions	Typical	Maximum	Units	
Voltage accuracy		± 1	± 3	%	
Line regulation	Full load (Vin min to Vin max)		+ Vout - Vout	± 0.5 ± 1	%
Load regulation	5 ~ 100% load		+ Vout - Vout	± 1 ± 1.5	%
Cross regulation	Dual outputs, Vo1 50% load, Vo2 25%~100% load			± 5	%
Over current protection		> 110	300	% of Iout	
Short circuit protection		Continuous, Auto recovery			

Temperature coefficient	Full load		± 0.03	%/°C
Ripple & Noise*	20MHz bandwidth, 5 ~ 100% load		60	100
Transient recovery time	25% load step change		300	500
Transient response deviation	25% load step change	Output 5V / $\pm 5V$	± 5	± 8
		Others	± 3	± 5

* Ripple and Noise are measured at 20MHz bandwidth by using a 1 μ F (M/C) and 22 μ F (E/C) parallel capacitor and typical input with full load

General Specifications				
Parameters	Conditions	Typical	Maximum	Units
Switching frequency	100% load. PWM mode	300		KHz
Operating temperature	See derating graph	-40 to +105		°C
Storage temperature		-55 to +125		°C
Soldering temperature	1.5mm from case 10 sec max		300	°C
Cooling	Free air convection			
Humidity	Non-condensing		95	% RH
Case material	Heat resistant black Plastic (flammability to UL 94V-0)			
Vibration	10-150Hz, 5G, 0.75mm along X,Y and Z			
Weight	PCB mountable model	4.5		g
Dimensions (L x W x H)	PCB mountable model	0.87 x 0.37 x 0.47 inches, 22.00 x 9.50 x 12.00mm		
MTBF	> 1 000 000 hrs (MIL-HDBK -217F, t _a +25°C) / Full Load			

Safety Specifications		
Parameters		
Standards	Designed to meet EN 62368-1	
	EMC - Conducted and radiated emission	CISPR32/EN55032, CLASS A with EMI CLASS A recommended circuit CISPR32/EN55032, CLASS B with EMI CLASS B recommended circuit
	Electrostatic Discharge Immunity	IEC 61000-4-2 Contact $\pm 4KV$, Criteria B
	RF, Electromagnetic Field Immunity	IEC 61000-4-3 10V/m, Criteria A
	Electrical Fast Transient/Burst Immunity	IEC 61000-4-4 $\pm 2KV$, Criteria B with EMS recommended circuit
	Surge Immunity	IEC 61000-4-5 L-L $\pm 2KV$, Criteria B with EMS recommended circuit
	RF, Conducted Disturbance Immunity	IEC 61000-4-6 3Vr.m.s, Criteria A

Derating

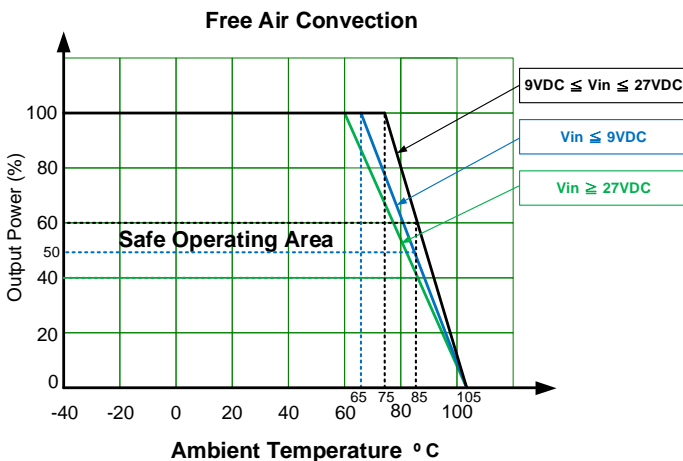

CODICO GmbH

Zwingenstraße 6-8, 2380 Perchtoldsdorf, Austria
 Telefon: +43 1 86 305-0, Fax: +43 1 86 305-5000
 e-mail: office@codico.com, www.codico.com
 FN 436940i, Landesgericht Wr. Neustadt

Zertifiziert nach ISO 9001:2008

Typical Application Circuit



Single output

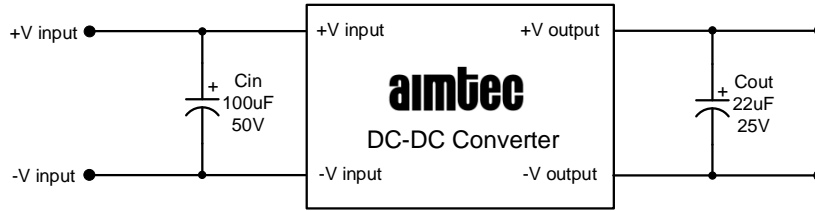

Dual output

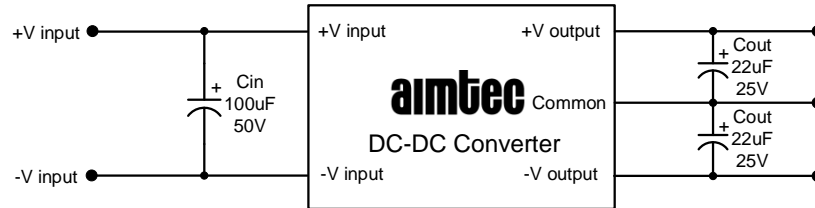

The products do not support parallel connection of their output.

EMC Recommended Circuit



For EMI CLASS A recommended circuit, single output models

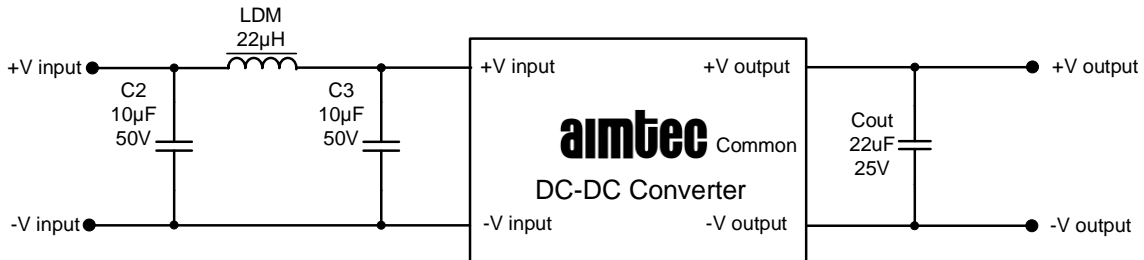

For EMI CLASS B and EMS recommended circuit, single output models

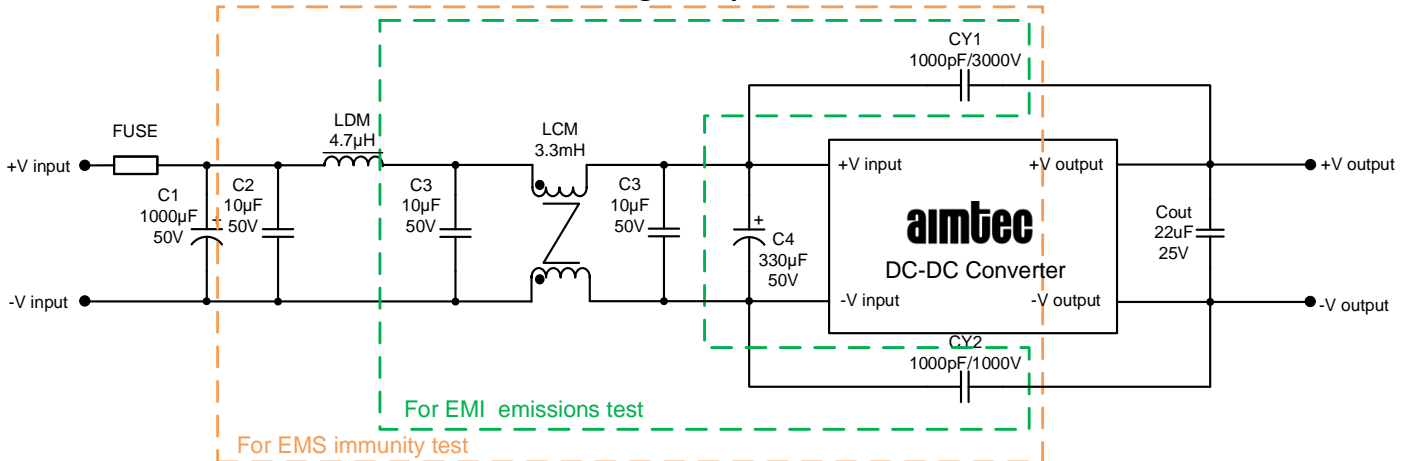

For EMI CLASS A recommended circuit, dual output models

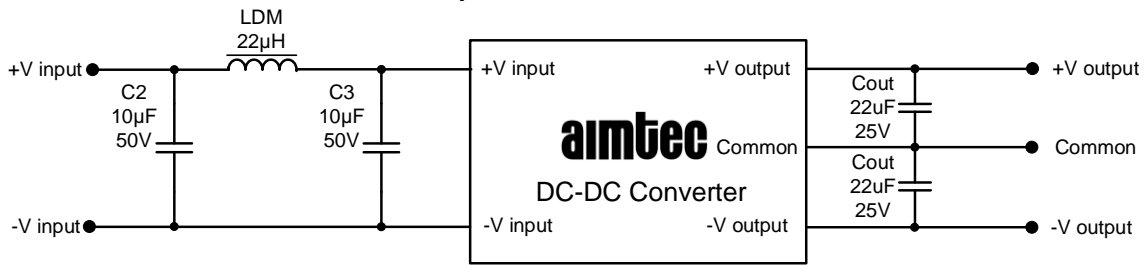

For EMI CLASS B and EMS recommended circuit, dual output models

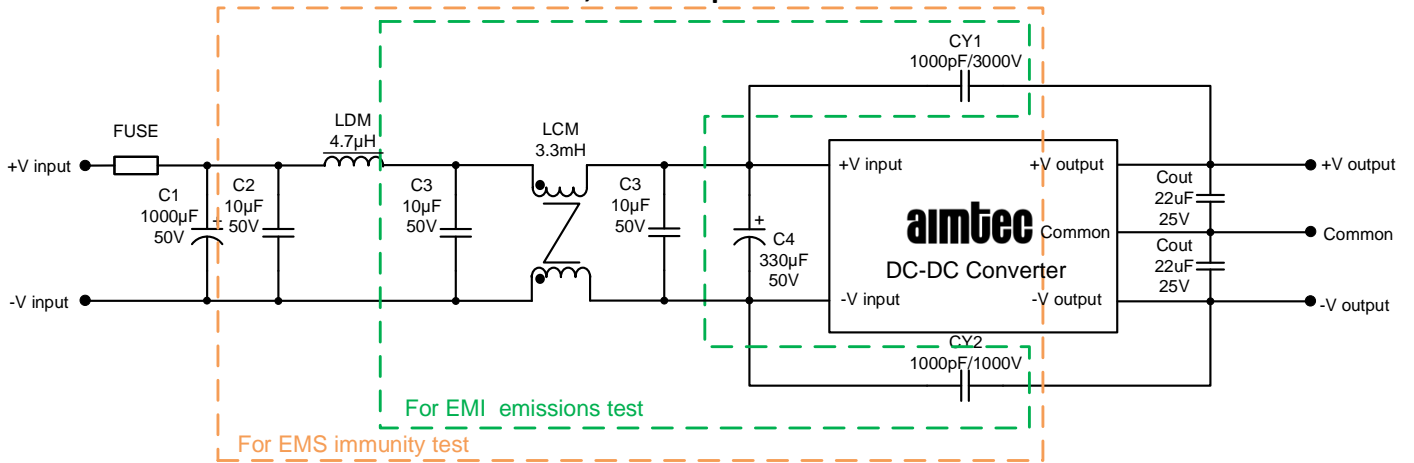

Fuse : Choose according to actual input current.

Dimensions

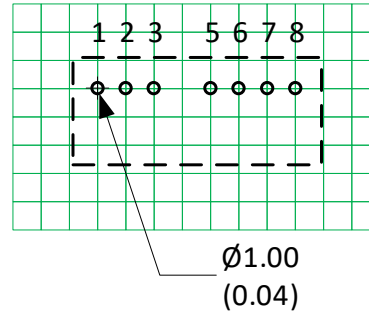
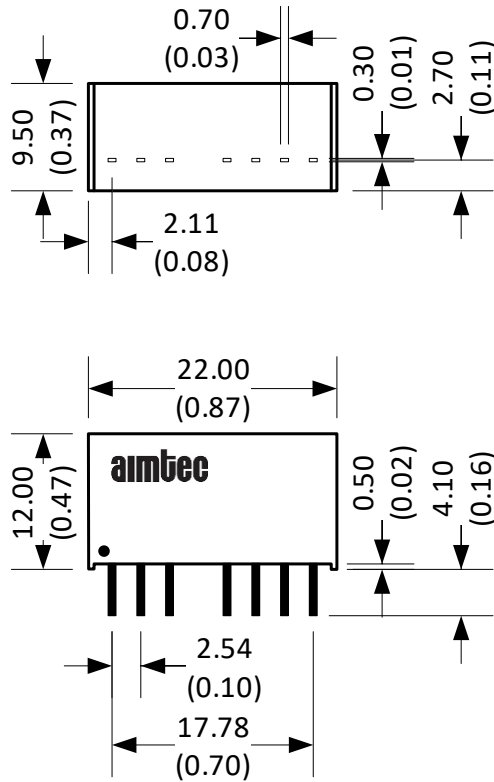

Note : Grid 2.54*2.54 mm

Notes:

All dimensions are typical in millimeters (inches).

Pin section tolerances : ± 0.10 (± 0.004)

General tolerance : ± 0.50 (± 0.02)

Pin Out Specifications		
Pin	Single	Dual
1	-V Input	-V Input
2	+V Input	+V Input
3	NC	NC
5	NC	NC
6	+V Output	+V Output
7	-V Output	Common
8	NC	-V Output



CODICO GmbH

Zwingenstraße 6-8, 2380 Perchtoldsdorf, Austria
Telefon: +43 1 86 305-0, Fax: +43 1 86 305-5000
e-mail: office@codico.com, www.codico.com
FN 436940i, Landesgericht Wr. Neustadt

Zertifiziert nach ISO 9001:2008

NOTE: 1. Datasheets are updated as needed and as such, specifications are subject to change without notice. Once printed or downloaded, datasheets are no longer controlled by Aimtec; refer to www.aimtec.com for the most current product specifications. **2.** Product labels shown, including safety agency certifications on labels, may vary based on the date manufactured. **3.** Mechanical drawings and specifications are for reference only. **4.** All specifications are measured at an ambient temperature of 25°C, humidity<75%, nominal input voltage and at rated output load unless otherwise specified. **5.** Aimtec may not have conducted destructive testing or chemical analysis on all internal components and chemicals at the time of publishing this document. CAS numbers and other limited information are considered proprietary and may not be available for release. **6.** This product is not designed for use in critical life support systems, equipment used in hazardous environments, nuclear control systems or other such applications which necessitate specific safety and regulatory standards other the ones listed in this datasheet. **7.** Warranty is in accordance with Aimtec's standard Terms of Sale available at www.aimtec.com.