

6222N-IMB

Wi-Fi Dual-band 1X1 802.11a/b/g/n +BLE5.0

IoT Module Datasheet



6222N-IMB Module Datasheet

Office: 6 Floor, Building U6, Junxiang U8 Park,
Hangcheng Avenue, Bao'an District,
Shenzhen City, CHINA

Factory: No.8, Litong Road, Liuyang Economic & Technical
Development Zone, Changsha, Hunan, CHINA

TEL: +86-755-2955-8186

Website: www.fn-link.com

Customer Approval : _____ Company

Title

Signature

Date

Fn-Link

Revision History

Version	Date	Revision Content	Draft	Approved
1.0	2020/07/25	Initial release	Lxy	Lgp
1.1	2020/12/21	Update tx power limit	Lxy	SZS
1.2	2021/3/12	Update PCB to 0.8mm	Lxy	SZS
1.3	2021/7/8	Update BLE tx power	LXY	QJP

CONTENTS

1 Overview.....	1
1.1 Introduction.....	1
1.2 Features.....	1
1.3 Block diagram.....	2
1.4 General specification.....	3
1.5 Operating Conditions.....	3
※1.6 EEPROM Information.....	3
2 Wi-Fi RF Specification.....	5
2.1 2.4GHz RF Specification.....	5
2.2 5GHz RF Specification.....	6
2.3 5GHz(20MHz) Channel table.....	7
3 Bluetooth Specification.....	8
4 Power Consumption.....	9
5 Pin Assignments.....	10
5.1 Pin outline.....	10
5.2 Pin Definition.....	11
6 Dimensions.....	14
6.1 Module Picture.....	14
6.2 Physical Dimensions.....	14
6.3 Layout Recommendation.....	15
7 Timing Information.....	17
8 Reference Information.....	18
9 Ordering Information.....	18
10 The Key Material List.....	19
11 Recommended Reflow Profile.....	19
12 Package Information.....	21
12.1 Reel.....	21
13 Moisture sensitivity.....	22

1 Overview

1.1 Introduction

6222N-IMB is a highly integrated IoT module with low power 802.11a/b/g/n Wireless LAN (WLAN) and Bluetooth Low Energy communication controller. It combines a high-performance KM4 MCU, a low power KM0 MCU, WLAN (802.11 a/b/g/n) MAC, a 1T1R capable WLAN baseband, RF, Bluetooth.

High speed connectivity interfaces, SDIO and USB are provided. Also audio codec, key-scan and touch keys integrated. Flexible design configures GPIO to different functions.

6222N-IMB integrates internal memories for complete Wi-Fi protocol functions.

1.2 Features

27*30mm with 1 IPEX connector version

System and memory

- Dual processor core
- KM4: Armv8-M with cortex-m33
- KM0: Armv8-M with cortex-m23
- 512kB SRAM@200MHz
- 4MB external flash
- 64 GPIO pins
- IPC: inter-processor communication

Wireless

- 802.11a/b/g/n 1x1 2.4G&5GHz
- 20MHz/40MHz up to MCS7
- Very low power suspends mode(DLPS)
- BLE5.0

Security

- Hardware engine: AES/DES/SHA hardware engine.
- Secure boot supported
- Debug port access protection and prohibition modes
- Secure efuse
- Flash decryption on the fly

Communication internaces

- SD/SDIO2.0 SDR25

- USB2.0
- SPI
- UART
- IR
- SGPIO
- I2C
- USI

Audio

- Sampling frequency:8/16/32/44.1/48/88.2/9KHz
- Integrates earphone driver 40mW on 16 Ω load/ 20mW on 32 Ω load
- Gain step: 0.375dB/step ,gain range: -64.5dB~0dB
- Audio output mode Line-out cap-less mode /differential mode/ single-ended mode
- I2S

Timer

- PWM
- RTC

Human machine interaction

- Key-matrix
- Cap-touch
- LCD

Analog

- ADC

1.3 Block diagram

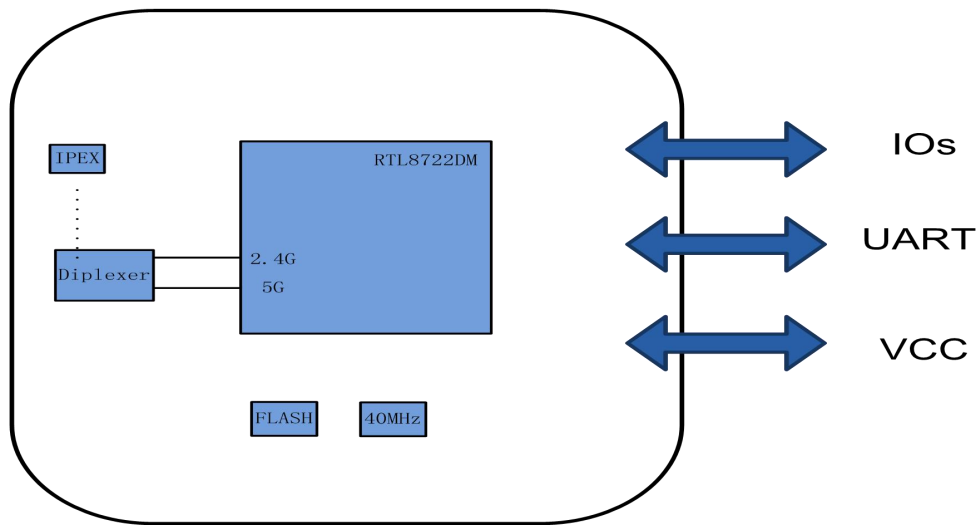

1.4 General specification

Model Name	6222N-IMB
Main Chipset	Realtek RTL8722DM
Host Interface	SD,SDIO,USB,UART, SPI,I2C, GPIO...
Wi-Fi Standards	802.11a/b/g/n
Bluetooth	BLE5.0
Dimension	L x W x H: 27*30*3.15mm
RoHS	All hardware components are fully compliant with EU RoHS directive

1.5 Operating Conditions

Operating Voltage	3.0-3.6 Vdc or 1.76-2.035Vdc
Operating Temperature	-20°C to +85°C
Storage Temperature	-40°C to +125°C

※1.6 EEPROM Information

Wi-Fi

Vendor ID	-
-----------	---

Device ID	-
BT	
Vendor ID	-
Product ID	-

2 Wi-Fi RF Specification

2.1 2.4GHz RF Specification

Feature	Description			
WLAN Standard	IEEE 802.11 b/g/n Wi-Fi compliant			
Frequency Range	2.400~2.4835GHz			
Number of Channels	Wi-Fi: USA/Canada: channel 1~11; Europe/China/Australia: channel 1~13; Japan: channel 1~14			
Spectrum Mask	Min. b/g/n	Typ. b/g/n	Max. b/g/n	Unit b/g/n
1st side lobes(to fc ± 11MHZ)	-	-43/-30/-40	-	dBr
2st side lobes(to fc ± 22MHZ)	-	-52/-33/-58	-	dBr
Freq. Tolerance	-20/-20/-20	-	20/20/20	ppm
Test Items	Typical Value			EVM
Output Power ¹	802.11b /11Mbps : 18dBm ± 1.5 dB			EVM ≤ -10dB
	802.11g /54Mbps : 17dBm ± 1.5 dB			EVM ≤ -25dB
	802.11n /MCS7 : 16dBm ± 1.5 dB			EVM ≤ -28dB
Test Items	Test Value			Standard Value
SISO Receive Sensitivity (11b,20MHz) @8% PER	- 1Mbps	PER @ -94 dBm	≤-83 dBm	
	- 2Mbps	PER @ -92 dBm	≤-80 dBm	
	- 5.5Mbps	PER @ -89 dBm	≤-79 dBm	
	- 11Mbps	PER @ -87 dBm	≤-76 dBm	
SISO Receive Sensitivity (11g,20MHz) @10% PER	- 6Mbps	PER @ -89 dBm	≤-85 dBm	
	- 9Mbps	PER @ -88 dBm	≤-84 dBm	
	- 12Mbps	PER @ -87 dBm	≤-82 dBm	
	- 18Mbps	PER @ -86 dBm	≤-80 dBm	
	- 24Mbps	PER @ -84 dBm	≤-77 dBm	
	- 36Mbps	PER @ -80 dBm	≤-73 dBm	
	- 48Mbps	PER @ -77 dBm	≤-69 dBm	
SISO Receive Sensitivity (11n,20MHz) @10% PER	- 54Mbps	PER @ -75 dBm	≤-68 dBm	
	- MCS=0	PER @ -89 dBm	≤-85 dBm	
	- MCS=1	PER @ -86 dBm	≤-82 dBm	
	- MCS=2	PER @ -84 dBm	≤-80 dBm	
	- MCS=3	PER @ -82 dBm	≤-77 dBm	

	- MCS=4	PER @ -79 dBm	≤-73 dBm
	- MCS=5	PER @ -76 dBm	≤-69 dBm
	- MCS=6	PER @ -74 dBm	≤-68 dBm
	- MCS=7	PER @ -72 dBm	≤-67 dBm
SISO Receive Sensitivity (11n ,40MHz) @10% PER	- MCS=0	PER @ -89 dBm	≤-82 dBm
	- MCS=1	PER @ -86 dBm	≤-79 dBm
	- MCS=2	PER @ -83 dBm	≤-77 dBm
	- MCS=3	PER @ -80 dBm	≤-74 dBm
	- MCS=4	PER @ -77 dBm	≤-70 dBm
	- MCS=5	PER @ -74 dBm	≤-66 dBm
	- MCS=6	PER @ -72 dBm	≤-65 dBm
Maximum Input Level	802.11b: -10 dBm		
	802.11g/n: -20 dBm		
Antenna Reference	PCB antenna with 0~2 dBi peak gain		

1. MCS7 HT40 is calibrated, other rate power control by firmware driver;

2.2 5GHz RF Specification

Feature	Description			
WLAN Standard	IEEE 802.11 a/n Wi-Fi compliant			
Frequency Range	4.900 GHz ~ 5.845 GHz (5.0 GHz Band)			
Spectrum Mask	Min. b/g/n	Typ. b/g/n	Max. b/g/n	Unit b/g/n
1st side lobes(to fc ± 11MHZ)	-	-43/-30/-40	-	dBr
2st side lobes(to fc ± 22MHZ)	-	-52/-33/-58	-	dBr
Freq. Tolerance	-20/-20/-20	-	20/20/20	ppm
Test Items	Typical Value			EVM
Output Power ¹	54Mbps : 14dBm ± 1.5 dB			EVM ≤ -25dB
	HT20 /MCS7 : 13dBm ± 1.5 dB			EVM ≤ -28dB
	HT40 /MCS7 : 13dBm ± 1.5 dB			EVM ≤ -28dB
Test Items	Test Value			Standard Value
SISO Receive Sensitivity (11a,20MHz) @10% PER	- 6Mbps	PER @ -87 dBm	≤-85 dBm	
	- 9Mbps	PER @ -86 dBm	≤-84 dBm	
	- 12Mbps	PER @ -85 dBm	≤-82 dBm	
	- 18Mbps	PER @ -84 dBm	≤-80 dBm	
	- 24Mbps	PER @ -82 dBm	≤-77 dBm	
	- 36Mbps	PER @ -78 dBm	≤-73 dBm	

	- 48Mbps	PER @ -75 dBm	≤-69 dBm
	- 54Mbps	PER @ -73 dBm	≤-68 dBm
SISO Receive Sensitivity (11n,20MHz) @10% PER	- MCS=0	PER @ -87 dBm	≤-85 dBm
	- MCS=1	PER @ -84 dBm	≤-82 dBm
	- MCS=2	PER @ -82 dBm	≤-80 dBm
	- MCS=3	PER @ -80 dBm	≤-77 dBm
	- MCS=4	PER @ -77 dBm	≤-73 dBm
	- MCS=5	PER @ -74 dBm	≤-69 dBm
	- MCS=6	PER @ -72 dBm	≤-68 dBm
SISO Receive Sensitivity (11n ,40MHz) @10% PER	- MCS=0	PER @ -87 dBm	≤-82 dBm
	- MCS=1	PER @ -84 dBm	≤-79 dBm
	- MCS=2	PER @ -81 dBm	≤-77 dBm
	- MCS=3	PER @ -78 dBm	≤-74 dBm
	- MCS=4	PER @ -75 dBm	≤-70 dBm
	- MCS=5	PER @ -72 dBm	≤-66 dBm
	- MCS=6	PER @ -70 dBm	≤-65 dBm
Maximum Input Level	802.11b: -10 dBm		
	802.11g/n: -20 dBm		
Antenna Reference	PCB antenna with 0~2 dBi peak gain		

1. MCS7 HT40 is calibrated, other rate power control by firmware driver;
2. all measurement is base on 3.3V power supply.

2.3 5GHz(20MHz) Channel table

Band range	Operating Channel Numbers	Channel center frequencies(MHz)
5180MHz~5240MHz	36	5180
	40	5200
	44	5220
	48	5240
5260MHz~5320MHz	52	5260
	56	5280
	60	5300
	64	5320
5550MHz~5700MHz	100	5500

	104	5520
	108	5540
	112	5560
	116	5580
	120	5600
	124	5620
	128	5640
	132	5660
	136	5680
	140	5700
5745MHz~5825MHz	149	5745
	153	5765
	157	5785
	161	5805
	165	5825

3 Bluetooth Specification

Feature	Description		
General Specification			
Bluetooth Standard	BLE 5.0		
Host Interface	UART		
Frequency Band	2402 MHz ~ 2480 MHz		
Number of Channels	40 channels for BLE		
Modulation	GFSK, $\pi/4$ -DQPSK		
RF Specification			
	Min.	Typical.	Max.
Output Power		8 ± 1.5dBm	
Sensitive @PER=30.8%			-70 dBm
Maximum Input Level	-10 dBm		

4 Power Consumption

Operation Mode		Condition	Current		Unit
Power Mode	Scenario		3.3V	1.8V	
Deepsleep	Deepsleep	RTC timer 1KB retention RAM	7~8	7.8	uA
	Deepsleep with Key-Scan	RTC timer 1KB retention RAM Key-Scan	12~13	12~13	uA
	Deepsleep with Cap-Touch	RTC timer	20	16	uA
	(average current)	1KB retention RAM Cap-Touch			
Sleep	WoWLAN sleep power	KM4 power gate KM0 clock gate All RAM retained Wi-Fi retained	30~50	30~50	uA
Active	Wi-Fi Tx	CCK 18dBm @ 3.3V, and 15dBm @ 1.8V KM4 in active mode	257	224	mA
		OFDM 19dBm @ 3.3V, and 13dBm @ 1.8V KM4 in active mode	262	214	mA
	Wi-Fi Rx Idle	HT20 MCS0~7 normal mode KM4 in active mode Rx idle	50	81	mA
		HT20 MCS0~7 ultra-low power mode KM4 in active mode Rx idle	35	60	mA
	Wi-Fi Rx UDP	HT20 MCS0~7 ultra-low power mode KM4 in active mode UDP Rx @ 8Mbps	39	67	mA
WoWLAN	WoWLAN Rx Beacon	Rx beacon mode @ normal mode KM4 in sleep mode	28	45	mA
		Rx beacon mode @ ultra-low power mode KM4 in sleep mode	23	39	mA
	WoWLAN DTIM=1 (Average)	KM4 in sleep mode All SRAM retained Wi-Fi retained Shielding room	700~800	1100~1200	uA
		KM4 in sleep mode All SRAM retained Wi-Fi retained Open space	1~2	1.1~2	mA
Note: Ultra-low power mode side effect: ● OFDM: Rx Sensitivity Degree 2~4dBm ● CCK: Rx Sensitivity Degree 1~2dBm					

5 Pin Assignments

5.1 Pin outline

< TOP VIEW >

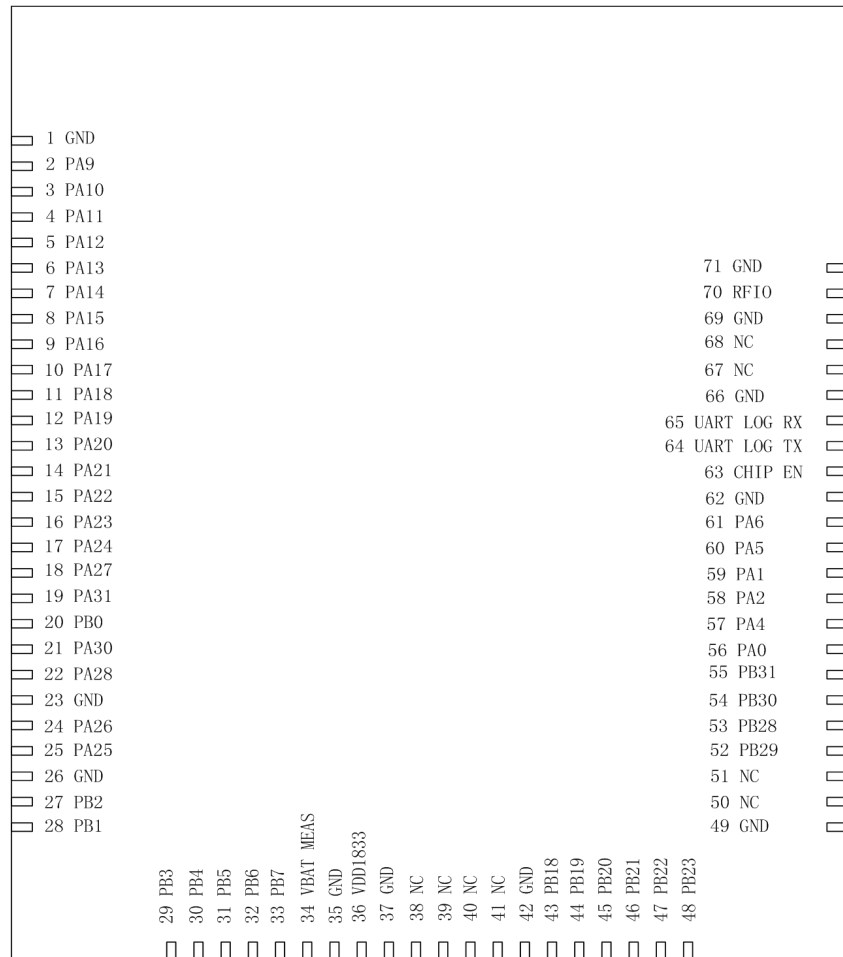

5.2 Pin Definition

Pin#	Name	Type	Description	Voltage
1	GND	-	Ground connection	
2	PA9	I/O	Muti function IO	
3	PA10	I/O	Muti function IO	
4	PA11	I/O	Muti function IO	
5	PA12	I/O	Muti function IO	
6	PA13	I/O	Muti function IO	
7	PA14	I/O	Muti function IO	
8	PA15	I/O	Muti function IO	
9	PA16	I/O	Muti function IO	
10	PA17	I/O	Muti function IO	
11	PA18	I/O	Muti function IO	
12	PA19	I/O	Muti function IO	
13	PA20	I/O	Muti function IO	
14	PA21	I/O	Muti function IO	
15	PA22	I/O	Muti function IO	
16	PA23	I/O	Muti function IO	
17	PA24	I/O	Muti function IO	
18	PA27	I/O	Muti function IO Normal mode sel: 1- normal operation, 0- enter into test mode. Not allowed to pull down when power on.	
19	PA31	I/O	Muti function IO	
20	PB0	I/O	Muti function IO	
21	PA30	I/O	Muti function IO SPS SEL: 1-SWR mode,(module pulled high) 0-LDO mode.	
22	PA28	I/O	Muti function IO	
23	GND	-	Ground connection	

24	PA26	I/O	Muti function IO, USB DP	
25	PA25	I/O	Muti function IO, USB DM	
26	GND	-	Ground connection	
27	PB2	I/O	Muti function IO	
28	PB1	I/O	Muti function IO	
29	PB3	I/O	Muti function IO	
30	PB4	I/O	Muti function IO	
31	PB5	I/O	Muti function IO	
32	PB6	I/O	Muti function IO	
33	PB7	I/O	Muti function IO	
34	VBAT MEAS	I	ADC IN	
35	GND	-	Ground connection	
36	VDD1833	P	POWER IN	1.8v or 3.3v
37	GND	-	Ground connection	
38	NC	-	No connection	
39	NC	-	No connection	
40	NC	-	No connection	
41	NC	-	No connection	
42	GND	-	Ground connection	
43	PB18	I/O	Muti function IO	
44	PB19	I/O	Muti function IO	
45	PB20	I/O	Muti function IO	
46	PB21	I/O	Muti function IO	
47	PB22	I/O	Muti function IO	
48	PB23	I/O	Muti function IO	
49	GND	-	Ground connection	
50	NC	-	No connection	
51	NC	-	No connection	
52	PB29	I/O	Muti function IO	
53	PB28	I/O	Muti function IO	
54	PB30	I/O	Muti function IO	
55	PB31	I/O	Muti function IO	
56	PA0	I/O	Muti function IO	
57	PA4	I/O	Muti function IO	
58	PA2	I/O	Muti function IO	

59	PA1	I/O	Muti function IO	
60	PA5	I/O	Muti function IO	
61	PA6	I/O	Muti function IO	
62	GND	-	Ground connection	
63	CHIP EN	I	Default high, Low shut down chip	
64	UART LOG TX	O	PA7, UART LOG OUT Uart download control: 1-boot from flash, 0-download image from UART.	
65	UART LOG RX	I	PA8, UART LOG IN	
66	GND	-	Ground connection	
67	NC	-	No connection	
68	NC	-	No connection	
69	GND	-	Ground connection	
70	RFIO	I/O	RF port, is not used	
71	GND	-	Ground connection	

P:POWER I:INPUT O:OUTPUT

6 Dimensions

6.1 Module Picture

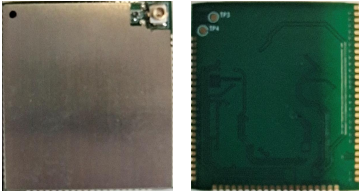
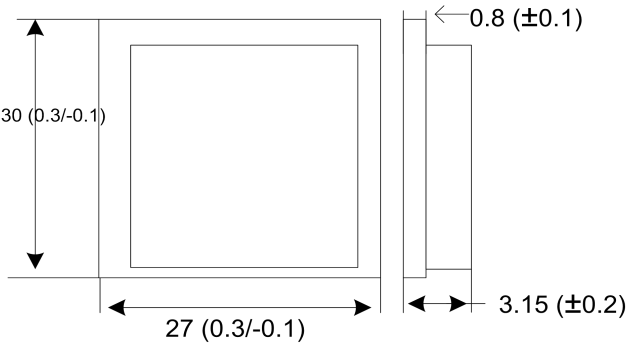
<p>L x W: 27 x 30 (+0.3/-0.1) mm</p> 	
<p>H: 3.15 (±0.2) mm</p>	
<p>Weight</p>	<p>3.17 g</p>

6.2 Physical Dimensions

(unit: mm)

< TOP VIEW >

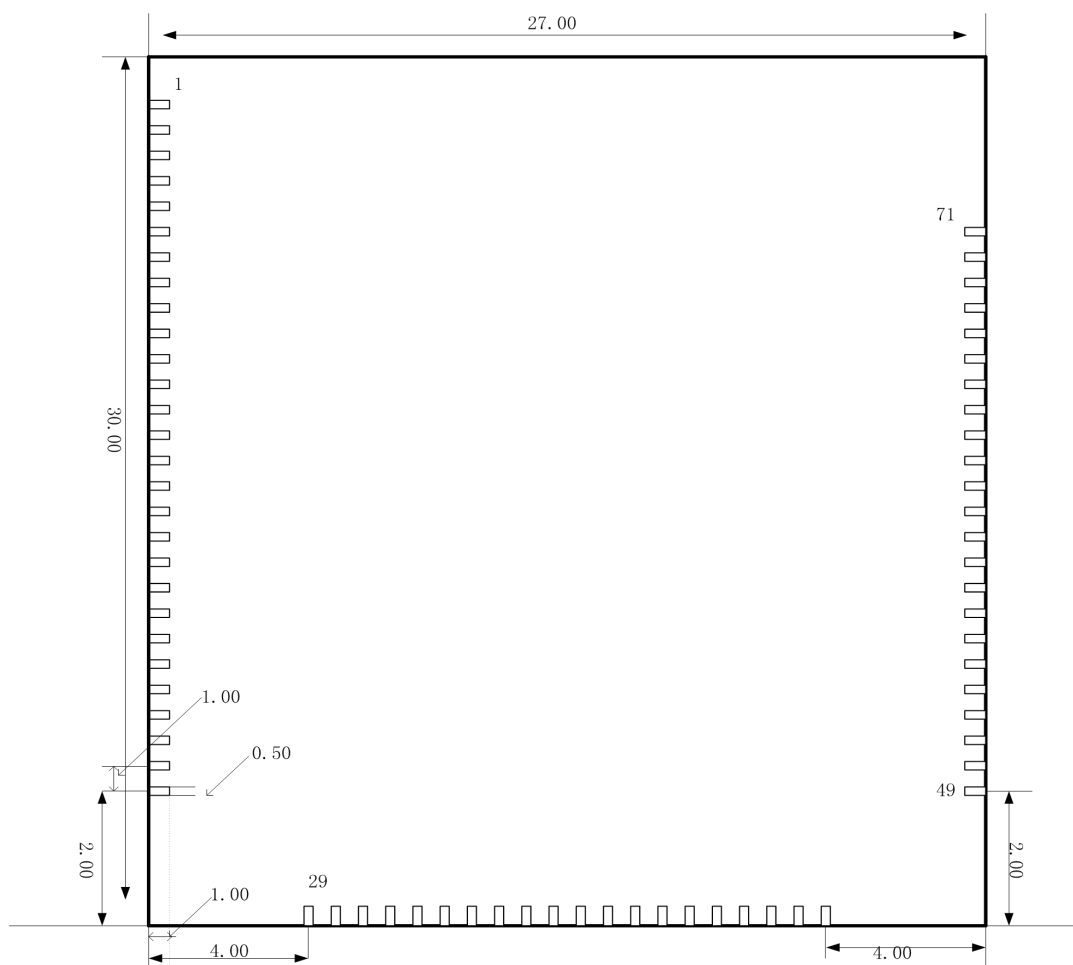

6.3 Layout Recommendation

(unit: mm)

< TOP VIEW >

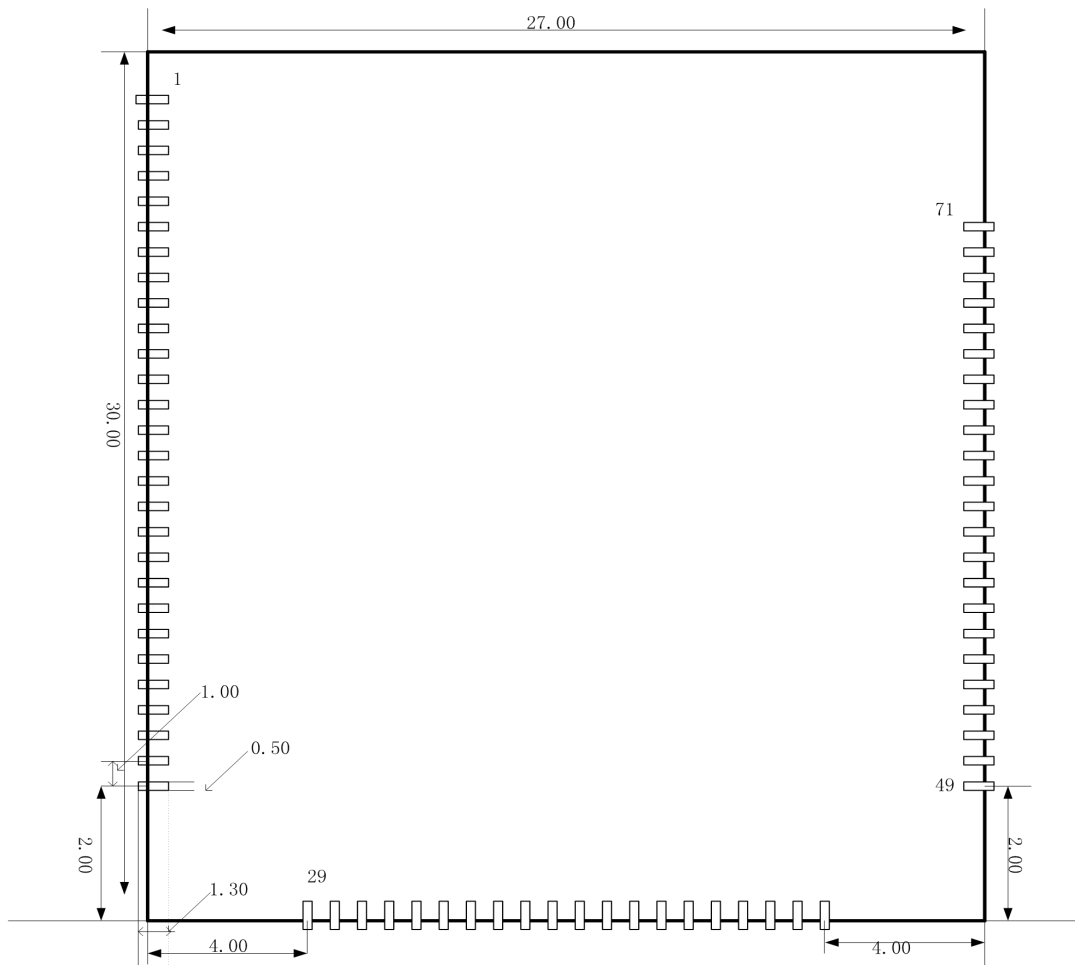

7 Timing Information

Power on or Resuming from Deepsleep Sequence

The timing sequence of power on or resuming from deepsleep is given in Fig 7-1.

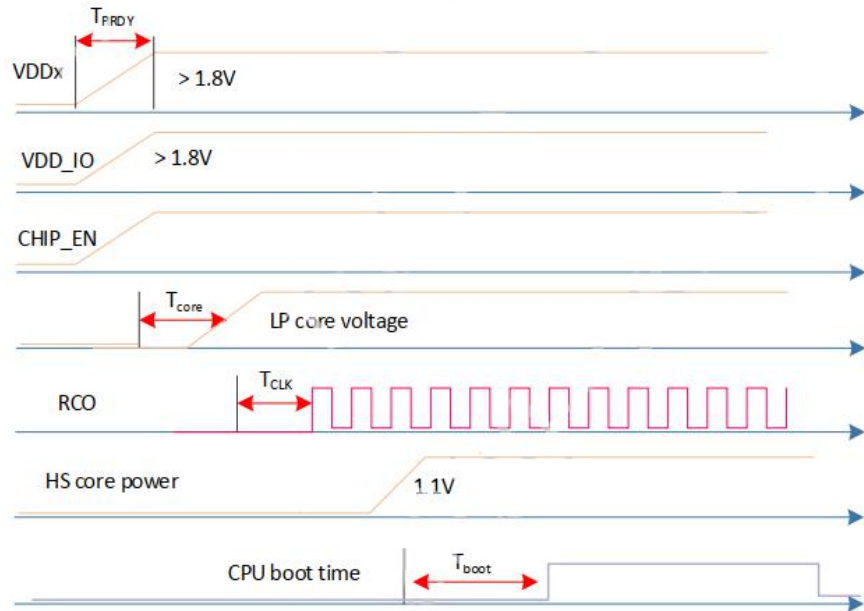

Fig 7-1 Timing sequence of power on or resuming from deepsleep

Shutdown Sequence

The timing sequence of shutdown is illustrated in Fig 7-2.

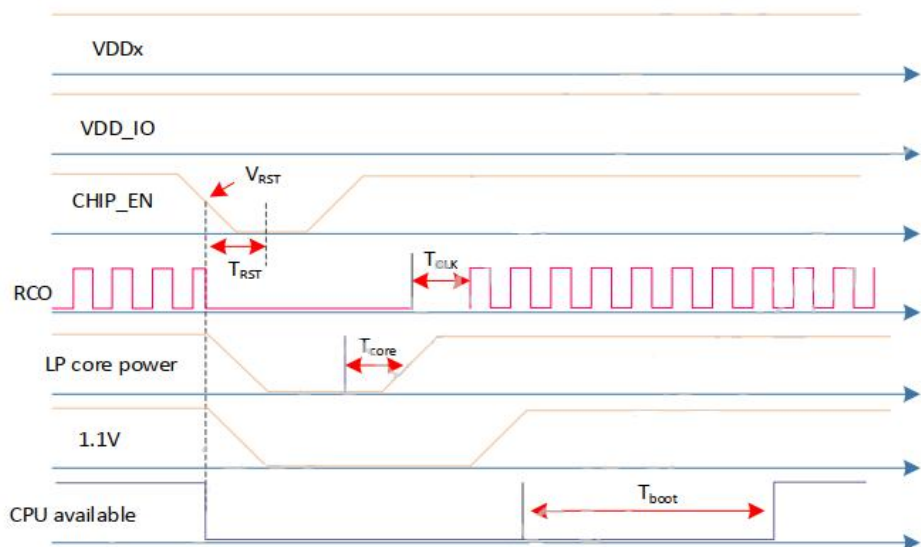
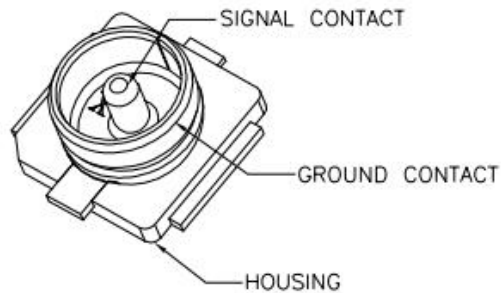
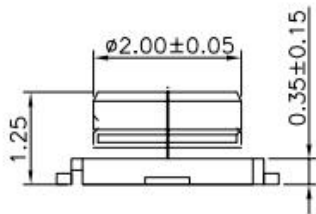
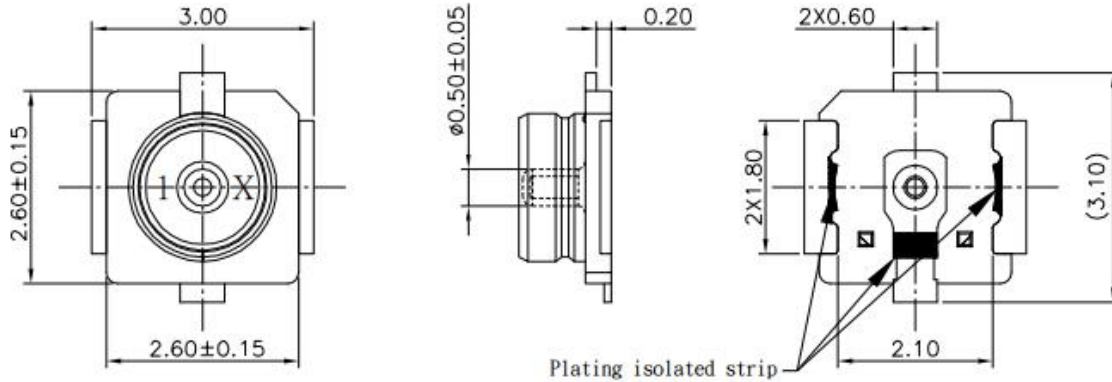

Fig 7-2 Timing sequence of shutdown

8 Reference Information

1. Pin mux detail list in other file named: RTL872xD-pinmux.xlsx
2. Details see chip datasheet file.
3. 6222N-IMB model ipex connector spec. as below.



6222N-IMB antenna connector shown.

9 Ordering Information

Part NO.	Description
FG6222NIMB-00	RTL8722DM,b/g/n/a,Wi-Fi+BLE5.0,1T1R,27X30mm,Uart+USB,w ith shielding,IPEX ,PCB 6V1
FG6222NIMB-K0	RTL8722DM,b/g/n/a,Wi-Fi+BLE5.0,1T1R,27X30mm,Uart+USB,w

	ith shielding,IPEX ,PCB 6V1,客供 IC
--	-----------------------------------

10 The Key Material List

Inductor	0805,2.2UH,±20%,>800mA	Chilisin, sunlord, cenke, ceaiya, microgate
Crystal	2016,40MHz, 15pF,10ppm	TKD,ECEC,HOSONIC,JWT
Chipset	RTL8722DM-VA1-CG QFN88 10x10mm	Realtek
Dixplexer	1.6*0.8 RFDIP1606L248D1T	Walsin,TDK,GLEAD,MAGL AYER
Flash	SOP-8P,150MIL 4MB	MXIC,Winbond,Gigadevice,Boya
IPEX	1代 UFLR-MINIPCL	佳沃, 创迪尔
PCB	6222N-IMB 6V1 green 2L FR4 Tg150 Au 27X30X0.8mm	Kx-pcb,xy-pcb,sl-pcb,sunlord

11 Recommended Reflow Profile

Refer to IPC/JEDEC standard.

Peak Temperature: <250°C

Number of Times: ≤2 times

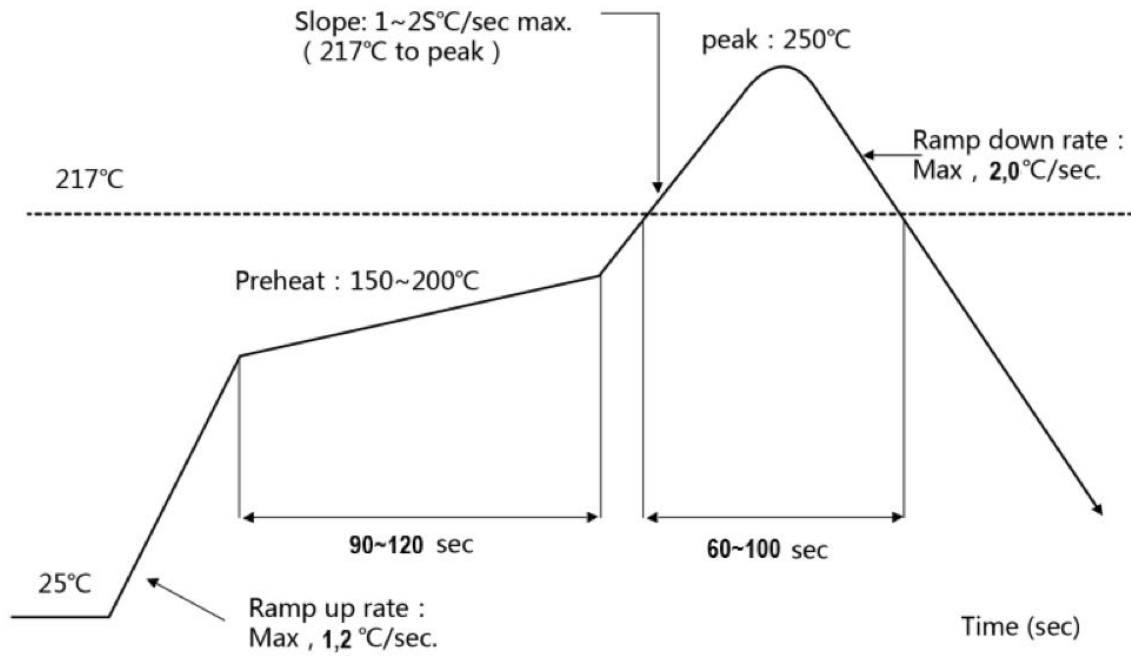
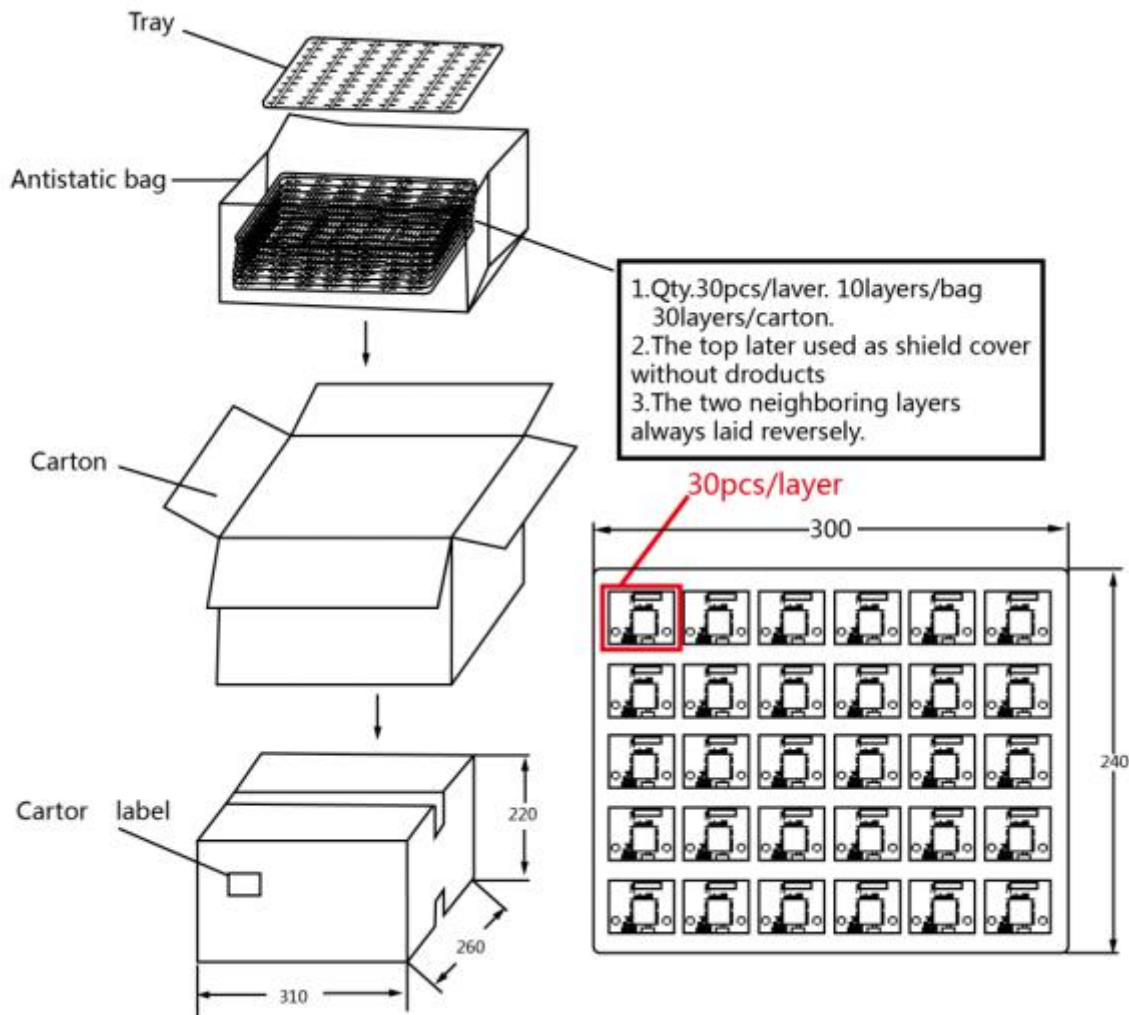

Figure11-1 Reference reflow profile

12 Package Information

12.1 Reel





The packing case size:335*255*360mm

13 Moisture sensitivity

The Modules is a Moisture Sensitive Device level 3, in according with standard IPC/JEDEC J-STD-020, take care all the relatives requirements for using this kind of components.

Moreover, the customer has to take care of the following conditions:

- a) Calculated shelf life in sealed bag: 12 months at <40°C and <90% relative humidity (RH)
- b) Environmental condition during the production: 30°C / 60% RH according to IPC/JEDEC J-STD-033A paragraph 5
- c) The maximum time between the opening of the sealed bag and the reflow process must be 168 hours if condition
- d) "IPC/JEDEC J-STD-033A paragraph 5.2" is respected
- e) Baking is required if conditions b) or c) are not respected
- f) Baking is required if the humidity indicator inside the bag indicates 10% RH or more