

ND Series

Differential Pressure Sensors Industrial Applications

- Highly integrated sensor with ADC and DSP
- Up to 7 Selectable Pressure Ranges per Device
- Pressure ranges 0.25 inH₂O (62.5 Pa) to 5 psi (345 mBar)
- 16-bit resolution (each selected range)
- Exceptional Zero Stability
- Integrated 50/60Hz Notch Filter
- Selectable Bandwidth Filter from 1.0Hz to 200Hz
- Output Data Rate up to 444Hz
- Total Error Band less than 0.15% FSS
- Very High Accuracy +/- 0.05% of Selected Range
- Long Term Stability +/- 0.05% FSS
- Silicon gel protection on psi rated models
- Temperature Compensated -20°C to 85°C
- Supply Voltage Compensation
- Fully Integrated Compensation Math
- Standard I²C and SPI Interface

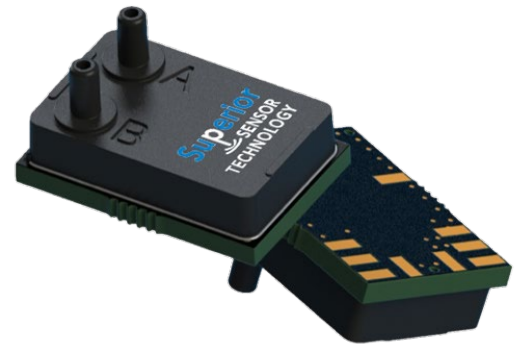

Product Summary

Based on Superior's NimbleSense™ architecture, the ND Series family extends the operating temperature down to -20°C and up to 85°C, while increasing pressures up to 5 psi (345mBar). Additionally, the ND utilizes the company's proprietary Multi-Range™ technology to create the industry's widest dynamic range. This wider dynamic range offers multiple pressure ranges in a single package thus minimizing the number of sensor variants required to support the demanding functional requirements of the various industrial market segments. For example, one Multi-Range enabled ND Sensor replaces up to 7 competing products greatly simplifying installation requirements and significantly lowering inventory costs.

Supporting pressure ranges as low as 0.25 inH₂O to as high as 5 psi, the ND Series is ideal for a wide variety of industrial applications from air curtains to aeronautics, from environmental chambers to eye surgery equipment, and from UAVs to 3D Printing.

The ND Series measures dry air and non-aggressive gas pressure with very high accuracy and a stable zero point. Non-linearity is also industry leading which is typically

0.05% FSS. The ND Series has a selectable bandwidth filter from 1Hz to 200Hz, and 16-bit resolution. For added performance, the ND Series has incorporated a 50/60Hz notch filter to minimize the impact of power noise spikes. Finally, the ND Series is an excellent choice for applications requiring the utmost reliability.

The ND Series provides a new level of integration combining an advanced piezoresistive sensing element with integrated amplification, ADC, DSP and a digital interface which greatly simplifies customer integration efforts. Advanced digital processing enables new functionality thus simplifying system development, adding manufacturing ease and increasing reliability.

Constructed with a high reliability plastic enclosure, the ND Series family provides the ideal combination of very high performance and reliability at extended temperature ranges while ensuring customers have a high volume, cost effective solution optimized for a wide array of industrial requirements.

Table of Contents

- 1 Maximum Ratings 2
- 2 Suggested Operating Conditions 2
- 3 Environmental 2
- 4 Equivalent Circuit..... 2
- 5 Feature List 3
- 6 Performance Characteristics 4
- 7 Electrical Characteristics..... 4
 - 7.1 Supply Characteristics..... 4
 - 7.2 Reset Characteristics 5
 - 7.3 DAV Characteristics 5
 - 7.4 I²C Characteristics 5
 - 7.5 SPI Characteristics 6
- 8 Materials..... 6
 - 8.1 Wetted Materials..... 6
 - 8.2 Material Compliance 6
- 9 System Overview 7
- 10 Interface 8
 - 10.1 Reset 8
 - 10.2 Communication Interface Selection 8
 - 10.3 SPI Interface..... 8
 - 10.4 I²C Interface 9
 - 10.4.1 I²C Address 9
 - 10.4.2 I²C Communications Model 9
 - 10.4.3 I²C Clock Stretching 10
 - 10.4.4 I²C Bus Compatibility..... 10
 - 10.5 Extended Data Acquisition 10
 - 10.5.1 Available Extended Data 10
 - 10.5.2 SPI Extended Data Read..... 10
 - 10.5.3 I²C Extended Data Read 10
 - 10.6 Control Registers 11
 - 10.6.1 Mode Control Register 11
 - 10.6.2 Rate Control Register 12
 - 10.7 Computing Pressure 12
- 11 Mechanical and Manufacturing..... 13
 - 11.1 Package Dimensions 13
 - 11.2 Suggested Pad Layout..... 13
 - 11.3 Pinout 14
 - 11.4 Reflow Soldering and Handling Conditions 14
 - 11.5 Pick and Place Pick-up Zone 14
 - 11.6 Packaging Options 15
 - 11.6.1 Tray Packaging 15
 - 11.6.2 Tape and Reel 16
 - 11.7 Part Identification 17
- 12 Packaging Labeling..... 17
- 13 Ordering Information 17
- 14 Revisions..... 18
- 15 Warranty..... 18

1 Maximum Ratings

Parameter	Sym	Min	Max	Units
Supply Voltage	V _{DDM}	Gnd-0.3	4.0	V
Voltage on I/O Pins	V _{DD} > 3.3V	Gnd-0.3	5.8	V
	V _{DD} ≤ 3.3V	Gnd-0.3	V _{DD} +2.5	V
I/O Current	I _{IOM}	-25	25	mA

2 Suggested Operating Conditions

Parameter	Sym	Min	Max	Units
Supply Voltage	V _{DDOP}	2.8	3.5	V
Temperature	T _A	-20	85	°C

3 Environmental

Parameter	Sym	Min	Max	Units	
Temperature Range	Compensated	T _{COMP}	-20	85	°C
	Operating	T _{OP}	-20	85	°C
	Storage	T _{STG}	-40	85	°C
Humidity (Non-condensing)	RH _{OP}	0	95	% RH	
Vibration (10Hz-2kHz)	G _{VIBE}	-	15	g	
Shock (6 ms)	G _{SHOCK}	-	100	g	
Life	CY _{LIFE}	1M	-	Cycles	

4 Equivalent Circuit

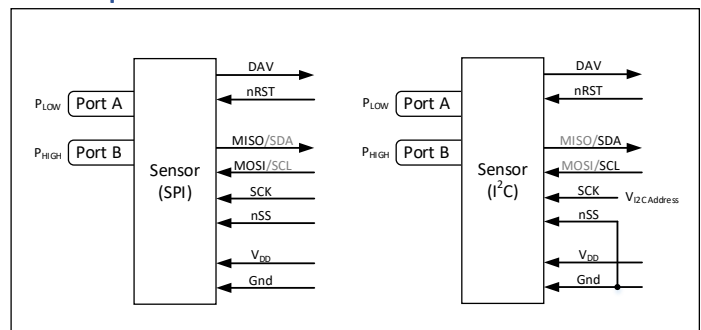

NDSeries

Industrial Pressure Sensors

5 Feature List

Low Pressure (inH₂O Ranges)

Parameter	Sym	ND210	ND110	ND120	ND130	Units	Notes
Number of FS Pressure Ranges	P _{NUM}	7	6	7	7	Each	
Specified FS Range Extents	P _{EXT}	±0.25 to ±10	±0.5 to ±10	±1.0 to ±20	±2.0 to ±30	inH ₂ O	
Number of BW Filter Corners	BW _{NUM}	8				Each	
BW Corner Frequency Extents	f _{BWEXT}	1.0 to 200				Hz	
Common Mode Pressure	P _{CM}	500	500	500	700	inH ₂ O	1
Proof Pressure	P _{PROOF}	40	40	40	100	inH ₂ O	2
Burst Pressure	P _{BURST}	120	120	120	200	inH ₂ O	3

Middle Pressure (psi Ranges)

Parameter	Sym	ND005D	Units	Notes
Number of FS Pressure Ranges	P _{NUM}	6	Each	
Specified FS Range Extents	P _{EXT}	±0.5 to ±5.0	psi	
Number of BW Filter Corners	BW _{NUM}	8	Each	
BW Corner Frequency Extents	f _{BWEXT}	1.0 to 200	Hz	
Common Mode Pressure	P _{CM}	25	psi	1
Proof Pressure	P _{PROOF}	15	psi	2
Burst Pressure	P _{BURST}	20	psi	3

- 1) Pressure applied to both ports simultaneously without incurring part damage.
- 2) Pressure at which the sensor will not suffer permanent damage.
- 3) Pressure if exceeded could cause permanent damage to the sensor.

6 Performance Characteristics

Note: Unless otherwise specified, characteristics specified with $V_{DD} = 3.3V$, $T_A = 25C$

Parameter	Sym	ND210			ND110/ND120/ND130			ND005D			Units	Notes
		Min	Typ	Max	Min	Typ	Max	Min	Typ	Max		
Accuracy	P_{ACC}	-	0.05	0.2	-	0.05	0.2	-	0.05	0.2	% RNG	1, 2
Total Error Band	TEB	-	0.10	0.3	-	0.15	0.75	-	0.07	0.5	% FSS	3
TEB After AZ	TEB_{AZ}	-	0.07	0.2	-	0.10	0.5	-	0.05	0.3	% FSS	7
Long Term Stability	LTS	-	0.10	0.25	-	0.15	0.35	-	0.05	0.15	% FSS/Yr	
Thermal Hysteresis	T_{HYS}	-	0.05	-	-	0.075	-	-	0.075	-	% FSS	
Pressure Hysteresis	P_{HYS}	-	0.05	-	-	0.05	-	-	0.05	-	% RNG	1
Position Sensitivity	P_{PS}	-	0.25	-	-	2.0	-	-	2.5	-	Pa	
Supply Rejection	P_{SR}	-	0.0005	-	-	0.0005	-	-	0.0005	-	Pa/mV	
Resolution	RES	-	16	-	-	16	-	-	16	-	bit	4
System ENOB	ENOB	-	17	-	-	17	-	-	17	-	Bit _{RMS}	5
Data Update Rate	f_{UPDATE}	432	444	456	432	444	456	432	444	456	Hz	6

- 1) Percentage of selected range.
- 2) Uncertainty limited by system noise for ranges of 0.5 inH₂O and below.
- 3) Includes errors of offset, span, hysteresis and thermal effects.
- 4) Each selected range has the specified resolution
- 5) ENOB stated for f_{BW} set to 1.0 Hz.
- 6) The internal update rate is fixed and does not change with range or filter settings. Sampling at lower data rates are possible provided the Nyquist frequency is observed. It is suggested to sample at least 3x the set f_{BW} frequency.
- 7) Total error band within 24 hours of a sensor auto-zero. Includes all error components of TEB.

7 Electrical Characteristics

7.1 Supply Characteristics

Parameter	Sym	ND210			ND110/ND120/ND130/ND005D			Units	Notes
		Min	Typ	Max	Min	Typ	Max		
Supply Current	I_{DD}	-	6.0	6.5	-	5.0	5.5	mA	
Supply Capacitance	C_{DD}	-	10	-	-	10	-	uF	1

- 1) Supply capacitance is provided within the part however it is recommended to include a 0.1 uF decoupling cap near the supply pads.

7.2 Reset Characteristics

Parameter	Sym	Condition	All ND Series Parts			Units	Notes
			Min	Typ	Max		
Power-On Reset Threshold	V_{PORR}	Rising Voltage on V_{DD}	-	1.4	-	V	
	V_{PORF}	Falling Voltage on V_{DD}	0.75	-	1.36	V	
Interface Detect Delay	t_{IOD}	From POR or External Reset	-	-	40	ms	
First Response Settling Time	t_{FRD}	From POR or External Reset	-	-	80	ms	1
External Reset Low	t_{RSTL}		15	-	-	us	
Input High Voltage	V_{IH}		$V_{DD}-0.6$	-	-		2
Input Low Voltage	V_{IL}		-	-	0.6		2
Internal Pull-Up Current	I_{PU}	$V_{IN} = 0V$	-	-10	-30	uA	2
Input Capacitance	C_{IN}		-	7	-	pF	2

1) The filter settling time to ensure the first reading is completely settled.

2) Input nRST

7.3 DAV Characteristics

Parameter	Sym	Condition	All ND Series Parts			Units	Notes
			Min	Typ	Max		
Output High Voltage	V_{OH}	$I_o = -3 \text{ mA}$	$V_{DD}-0.7$	-	-	V	
Output Low Voltage	V_{OL}	$I_o = 8 \text{ mA}$	-	-	0.6	V	

7.4 I²C Characteristics

Parameter	Sym	Condition	All ND Series Parts			Units	Notes
			Min	Typ	Max		
SCL Clock Frequency	f_{SCL}		100	-	400	kHz	
Clock Stretch Time	t_{CKSTR}		-	15	100	us	
Input High Voltage	V_{IH}		$V_{DD}-0.6$	-	-		
Input Low Voltage	V_{IL}		-	-	0.6		
Output Low Voltage	V_{OL}	$I_o = 8 \text{ mA}$	-	-	0.6	V	
Input Capacitance	C_{IO}		-	7	-	pF	

7.5 SPI Characteristics

Parameter	Sym	Condition	All ND Series Parts			Units	Notes
			Min	Typ	Max		
Output High Voltage	V _{OH}	I _o = -3 mA	V _{DD} -0.7	-	-	V	1
Output Low Voltage	V _{OL}	I _o = 8 mA	-	-	0.6	V	1
Input High Voltage	V _{IH}		V _{DD} -0.6	-	-		2, 3
Input Low Voltage	V _{IL}		-	-	0.6		2, 3
Internal Pull-Up Current	I _{PU}	V _{IN} = 0V	-	-10	-30	uA	2, 3
Time nSS to First SCK Edge	t _{SC}		100	-	-	us	
Clock Cycle Time	t _{CC}		6	-	-	us	
Byte to Byte Cycle Time	t _{BC}		100	-	-	us	
Time Last Clock to nSS High	t _{CN}		20	-	-	us	
Cycle Time nSS	t _{CS}		6	-	-	us	
Input Capacitance	C _{IN}		-	7	-	pF	2

- 1) Output MOSI
- 2) Inputs MISO, SCK, nSS
- 3) Inputs are 5V compliant.

8 Materials

8.1 Wetted Materials

Parameter	Sym	ND210		ND110/ND120/ND130		ND005D		Units	Notes
		P _A	P _B	P _A	P _B	P _A	P _B		
Wetted Materials	MAT _{WET}	Epoxy Nylon RTV Silicon Gold Aluminum	Epoxy Nylon RTV Silicon Gold Aluminum	Epoxy Nylon RTV Silicon	Epoxy Nylon RTV Silicon Gold Aluminum	Epoxy Nylon RTV Silicon	Epoxy Nylon RTV Silicon Gold Sil-Gel		

8.2 Material Compliance

Parameter	Sym	All ND Series Parts	Units	Notes
RoHS	REG _{RoHS}	RoHS Compliant		
REACH	REG _{REAC}	REACH Compliant		

9 System Overview

The ND Series pressure sensor is a fully integrated pressure acquisition system in a sensor module. The acquisition system includes anti-alias filters, data acquisition, 50/60Hz notch filter, sensor compensation, bandwidth limiting and I/O functions. Refer to the figure below for the ND Series block diagram.

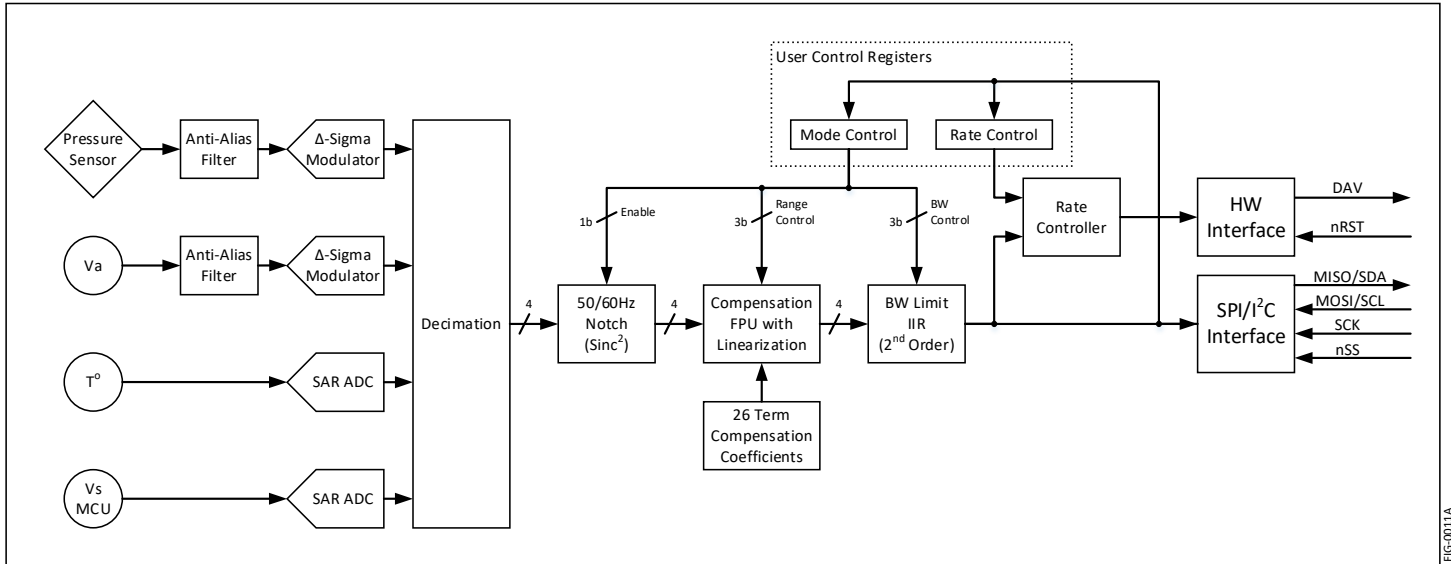

There are also two user controlled registers that tune the sensor to the specific user requirements. The first register is the Mode Control register that determines the output pressure range, the corner frequency of the bandwidth limiting filter and enables or disables the 50/60Hz notch filter.

The second register is the Rate Control register which controls the rate at which the Data Available (DAV) pin is asserted. The internal sensor data update rate of 444 Hz is often much faster than industrial requirements so the Rate Control register can throttle down the rate at which the Data Available pin (DAV) is asserted. The DAV is reset upon each read of the pressure sensor. An internal model of the Rate Controller is illustrated in the figure to the right.

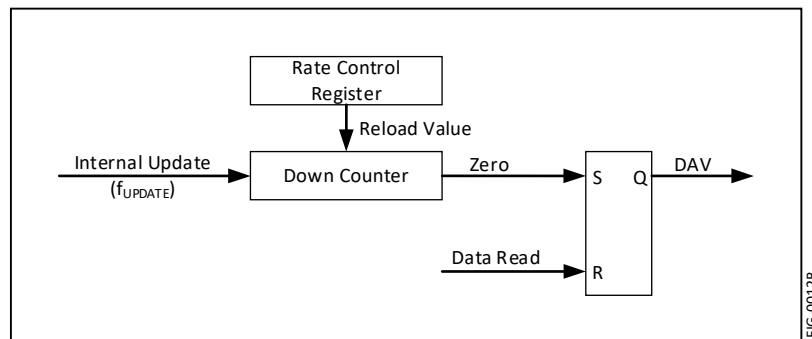

10 Interface

10.1 Reset

Reset timing is shown in the diagram below.

The communications method (SPI or I²C) is established during the time just after reset. During this time (t_{IOD}), no communications should take place.

Also, the internal filters are settling during the time t_{FRD} and data acquired during this time may not be fully settled.

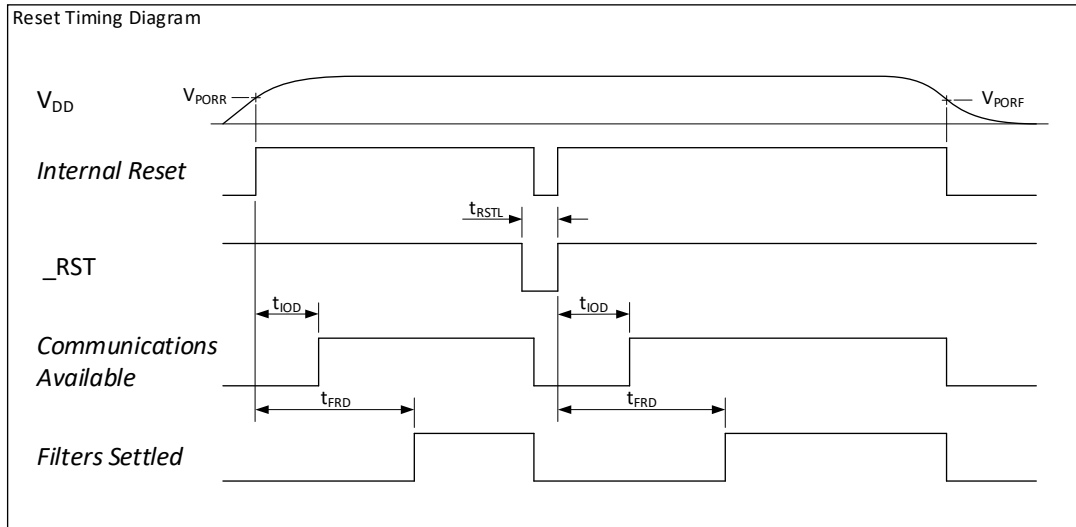

10.2 Communication Interface Selection

The communications interface is selected by interrogating the nSS pin after the internal power on reset delay. If nSS is high, the SPI interface will be selected otherwise (if low) the I²C interface will be selected. Grounding the nSS pin is an acceptable method for selecting the I²C interface. NOTE: The I²C interface supports 10 interface addresses. Refer to section 10.4.1 for the details on I²C address selection.

10.3 SPI Interface

The SPI interface uses a 16 bit transfer for all communications. Data is MSB first for both MOSI and MISO data transfers. Refer to the figure below for specific timing requirements.

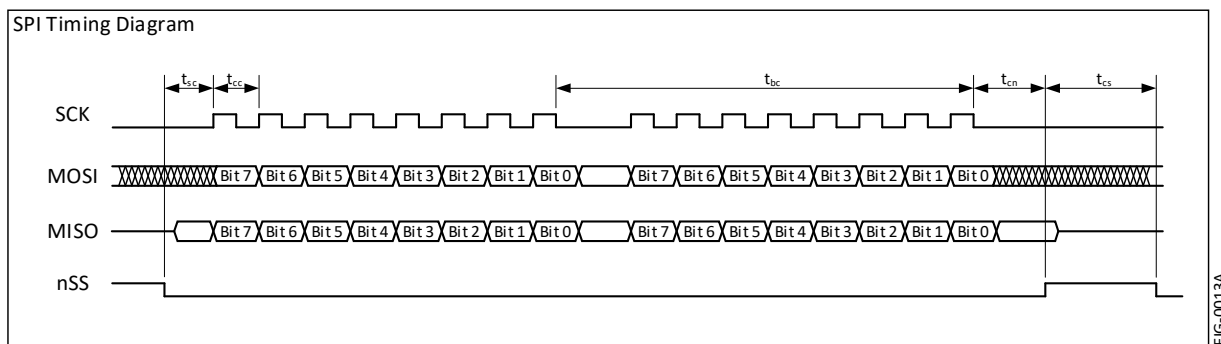

The data communications has been reduced to a simple 16 bit transfer model for reading the pressure output. Each communication cycle consists of master sending the Mode and Rate data to be placed into the sensor Mode Register and Rate Registers respectively. Simultaneously, the sensor sends the pressure data for the master to receive. Refer to the figure below for the data communication model of the ND Series sensor.

The requirement to send the Mode and Rate bytes on each data read cycle is intentional. The purpose is to force the master to send specific data for each communication and prevent inadvertent data from being sent to the sensor. Since a SPI interface will generally re-circulate data through its shift register, the intention is to prevent the pressure output from the sensor from being re-circulated back to the sensor and potentially causing unintended corruption of the intended mode register.

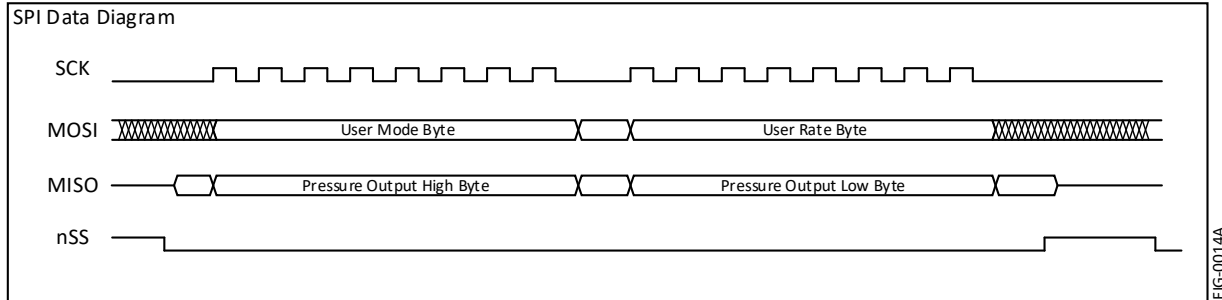

10.4 I²C Interface

The ND Series is compatible with the I²C protocol. For detailed information regarding the I²C protocol, please refer to the Philips I²C Bus Specification, Version 2.

10.4.1 I²C Address

I2C Address Selection Table			
R1 (kΩ)	R2 (kΩ)	Address (decimal)	Address (hex)
120	5.6	49	0x31
120	12	48	0x30
120	27	47	0x2F
120	51	46	0x2E
120	100	45	0x2D
56	100	44	0x2C
30	100	43	0x2B
15	100	42	0x2A
5.6	100	41	0x29
0	NoPop	40	0x28

The I²C address is set to 0x28 by grounding the SCK line. Other I²C addresses can be established by applying a voltage to the SCK line by use of a resistor divider across the sensor supply voltage. The suggested resistor values and the respective I²C address are shown in the table to the left.

Note: R1 is the lower resistor of the divider where R2 is the upper resistor of the divider.

10.4.2 I²C Communications Model

The sensor is configured as a slave device and as such, the communicating host must be configured as a master. There are two types of possible data transfers, data transfers from the master transmitter to an addressed sensor (WRITE), and data transfers from an addressed sensor to a master receiver (READ). The master device initiates both types of data transfers and provides the serial clock pulses on SCL.

The communications model for I²C is similar to that of SPI however, since I²C is a half-duplex protocol, the transfer of information to and from the sensor is separated into two separate communications. This is in contrast to the SPI interface where the transmitted and received data occurs simultaneously to and from the host. Refer to the figure to the right for the data communication model for the ND Series sensors.

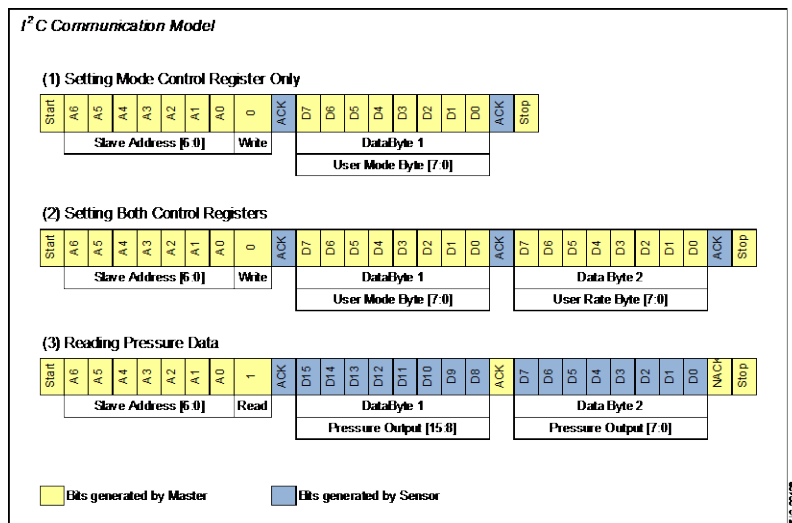

10.4.3 I²C Clock Stretching

The figure to the right illustrates the I²C clock stretching by the sensor. At times, the sensor requires additional time to respond to the host and utilizes the clock stretching feature of the I²C protocol. This is accomplished by holding the SCL low after the ACK cycle of a data transfer. Refer to Section 7.4 for the clock stretching timing. Note, the maximum clock stretch time will generally only occur once during the three ACK cycles of a two byte transfer. That is, the balance of ACK's during a multi-byte transfer will generally include the typical clock stretching time.

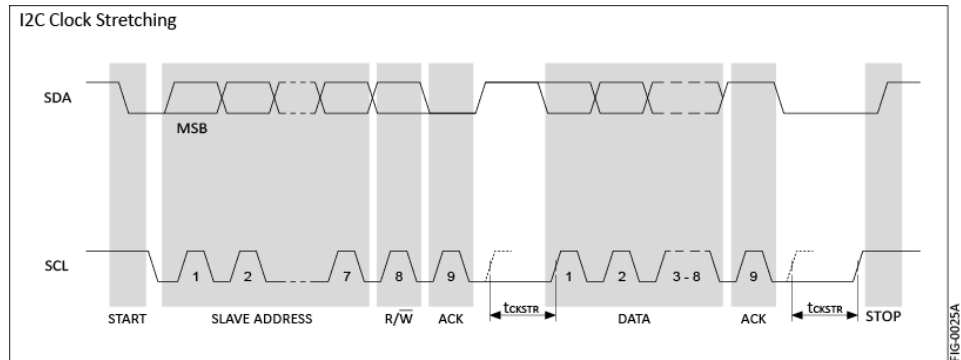

10.4.4 I²C Bus Compatibility

The I²C specification allows any recessive voltage between 3.0 and 5.0 V. Different devices on the bus may operate at different voltage levels. However, the maximum voltage on any port pin must conform to the electrical characteristics specifications (See section 1). The bi-directional SCL (serial clock) and SDA (serial data) lines must be connected to a positive power supply voltage through a pull-up resistor or similar circuit. Every device connected to the bus must have an open-drain or open-collector output for both the SCL and SDA lines, so that both are pulled high (recessive state) when the bus is free.

10.5 Extended Data Acquisition

10.5.1 Available Extended Data

For either the SPI or I²C interface, additional data is available beyond the pressure. The means to access this extended data is to continue reading data (either SPI or I²C) beyond the first 16 bits of pressure information. The following table defines the order of the available data and respective format.

Data	Bytes	Format	Interpretation	Example
Pressure	1-2	2 byte, Signed Int	See Section 10.7	See Section 10.7
Temperature	3-4	2 byte, Signed Int	Fixed Decimal [8.8 bits], Upper 8 bits integer, lower 8 bits fractional. Temperature in °C	1880H (18.80H) = 24.5°C
Model	5-12	8 byte, ASCII, null terminated	Right reading ASCII with null termination	4EH,44H,32H,31H,30H,00H,xxH,xxH = ND210 4EH,44H,30H,30H,35H,44H,00H,xxH = ND005D
Serial Number	13-16	4 byte, Hex	Unique 4 byte serial for each part	2FD627A4H
Software Number	17-22	6 byte, ASCII, null terminated	Right reading ASCII with null termination	30H,30H,30H,33H,43H,00H = 0003C

10.5.2 SPI Extended Data Read

Reading the extended data while using the SPI interface is the same as shown in Section 10.3 with exception that the master continues to read during the same nSS sequence to read all 22 bytes of the extended data. Any portion of the 22 bytes can be read during the transfer. That is, for example, 4 bytes could be read to acquire only the pressure and temperature information. When reading the extended data, only the first two bytes sent to the sensor (User Mode and User Rate) are used to set the internal registers. The subsequent bytes (bytes 5 through 22) are ignored. Data read following the first 22 bytes is undefined.

10.5.3 I²C Extended Data Read

Reading the extended data via the I²C interface is similar to using the SPI interface where the master can simply continue to reading the sensor during the pressure reading transfer. The master continues Ack'ing until the number of desired bytes are read.

10.6 Control Registers

10.6.1 Mode Control Register

Default Value: 0xF6

Details of the Mode Control register are illustrated in the figure to the right.

Bits 0-2 control the output pressure range.

Bit 3 is the I/O Watchdog Enable bit. When set, the I/O watchdog is enabled. When enabled, the I/O watchdog will monitor the I/O activity. If I/O activity is not detected for the I/O Watchdog timeout time, the pressure sensor will reset itself. The I/O watchdog timeout time is determined by the currently active bandwidth setting.

Bits 4-6 control the BW Limit Filter.

Bit 7 is the Notch Filter Enable bit. When enabled, the 50/60Hz notch filter is active.

Please note the available pressure ranges for the different sensor models are indicated in the table. For values where the pressure range is not available for the given sensor (high or low), the table is highlighted in light orange and indicates the given full scale value to use for pressure conversion. It is possible to use these values.

It should also be noted that upon changing the Mode Control value, there is a one cycle latency before the new Mode Control value becomes valid. That is, the data of the communication cycle following a change to the Mode Control register will not reflect the change. It is not until the second communication cycle that the change in the Mode Control register will be reflected in the output data.

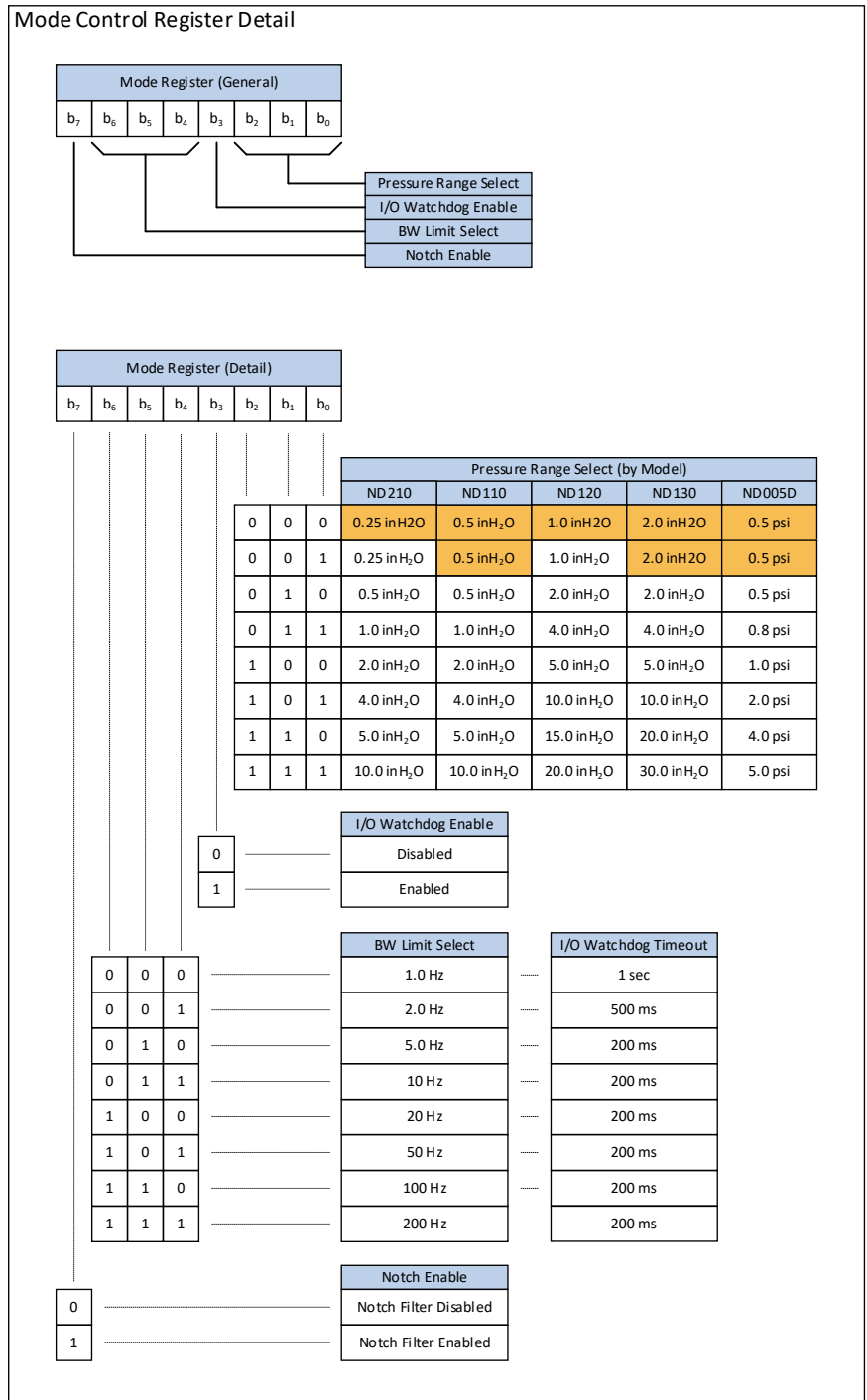

FIG-0083A

10.6.2 Rate Control Register

Default Value: 0x00

The Rate Control Register controls the rate at which the DAV pin is asserted indicating new data is available. This register is primarily used to throttle down the actual data transfer rate (when using the DAV as the trigger to sample) since the general industrial requirement is less than the internal 444 Hz update rate.

The function of this register is that it is the reload value of a data rate counter. The value of the Rate Control Register is the divisor of the 444 Hz internal data rate. Since a divisor of zero is not possible, a zero value will select the auto-select rate mode. In this mode, the rate is selected based on the selected bandwidth limit. The auto rate value is roughly 3x the corner frequency of the selected bandwidth limit in all auto selected rates (where possible).

Note: Start-up time for the sensor is approximately 80ms for the first sample to be settled. Requesting data during this time will result in invalid information. However, this start-up time can be used for configuring the Mode and Rate registers by performing a transfer with the desired Mode and Rate register values and discarding the received pressure data. After waiting the required start-up time, the sensor will respond with desired data since the Mode and Rate registers have been pre-established.

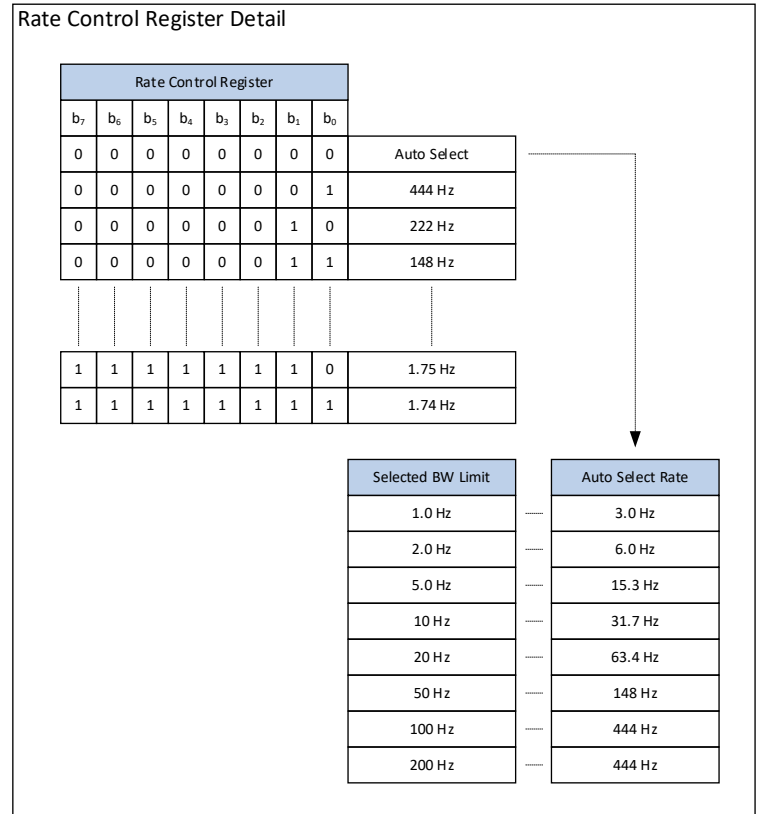

FIG-0084A

10.7 Computing Pressure

The pressure data is in the form of 16 bit signed integer sent in high byte then low byte order. This is a differential output by definition and the data range is $\pm 2^{15}$. There is a 10% margin in the output scaling and the selected full scale will reside in the 90% band of the total available output data range. Refer to Equation 1 (below) for the general model for computing the output pressure. As an example, if the sensor output is 3,647 counts and the selected pressure range is 1.0 inH₂O, then the output pressure is 0.124 inH₂O. Conversely, for a -3,647 count with the selected pressure range of 1.0 inH₂O, the computed output pressure is -0.124 inH₂O. Refer to Example 1 (below) for the specific example computation.

$$Eq\ 1: P_{inH_2O} = \frac{Out_{DIGITAL}}{90\% * 2^{15}} * Range_{SELECTED}$$

$$Example\ 1: P_{inH_2O} = \frac{3,647}{90\% * 2^{15}} * 1\ inH_2O = 0.124\ inH_2O$$

11 Mechanical and Manufacturing

11.1 Package Dimensions

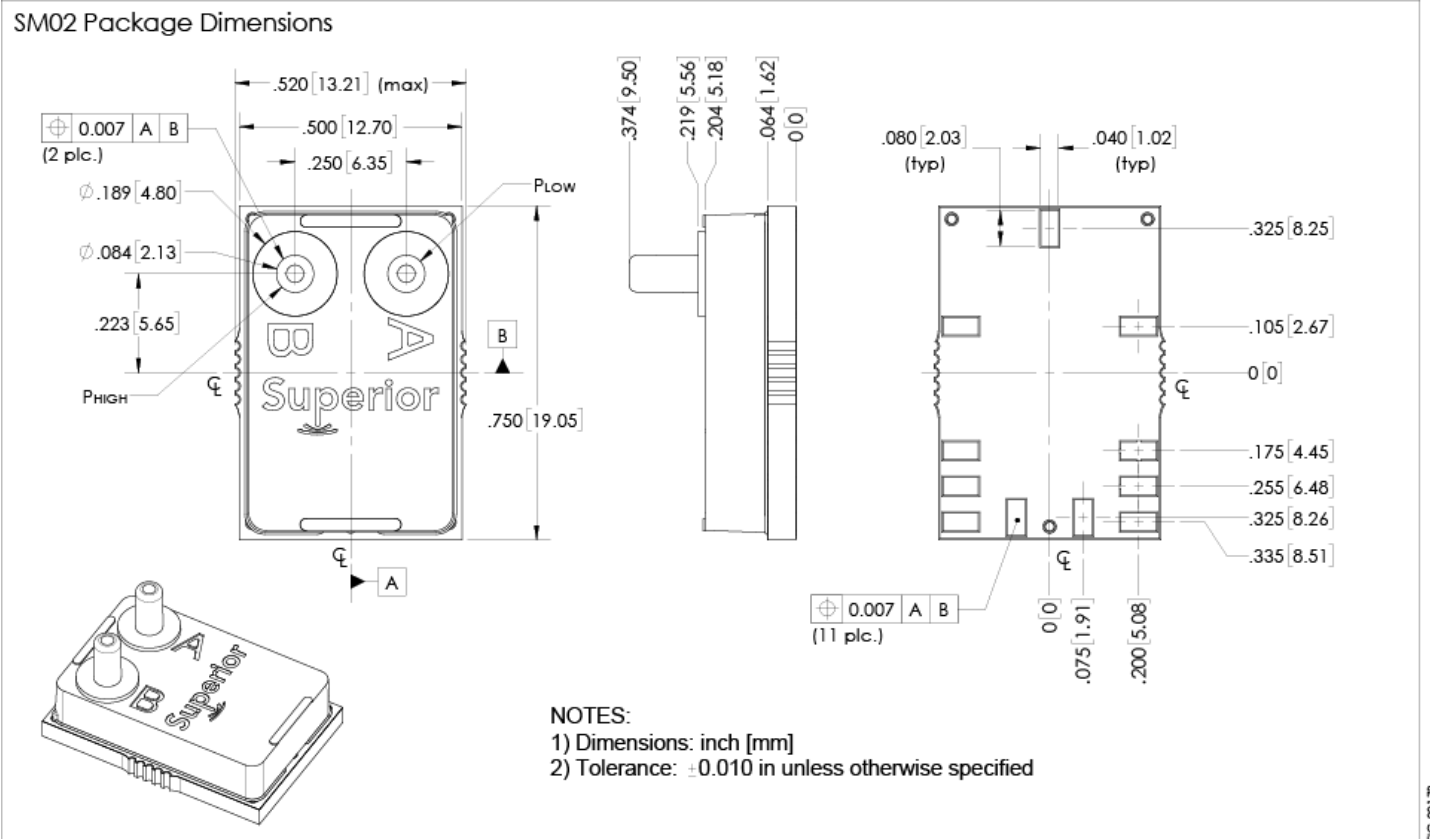

11.2 Suggested Pad Layout

The suggested pad layout is shown in the figure below. An Eagle PCB symbol library is available with the shown pad dimensions. Please consult the factory to obtain the library.

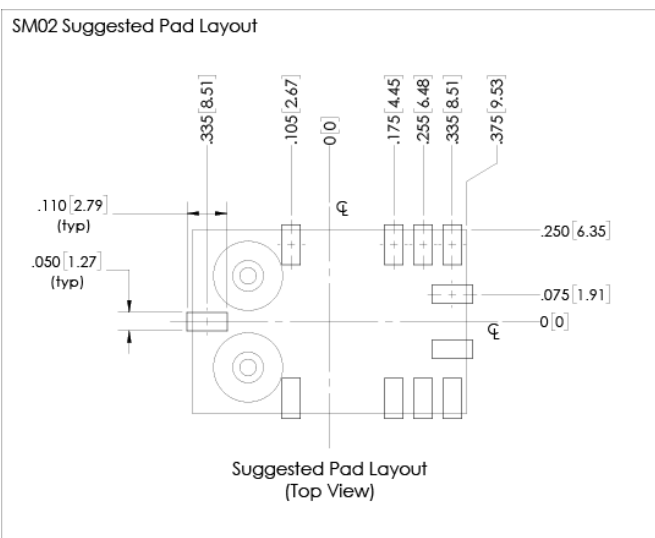

NDSeries

Industrial Pressure Sensors

11.3 Pinout

Pin	Sym	SPI	I ² C
1	nSS	Slave Select (active low)	Tie to Ground
2	MOSI/SCL	MOSI	SCL
3	MISO/SDA	MISO	SDA
4	SCK	Serial Clock	See Section 10.4.1
5	DNC	Do Not Connect	
6	DNC	Do Not Connect	
7	DNC	Do Not Connect	
8	Gnd	Ground	
9	V _{DD}	Sensor Supply	
10	nRST	Reset (active low)	
11	DAV	Data Available	

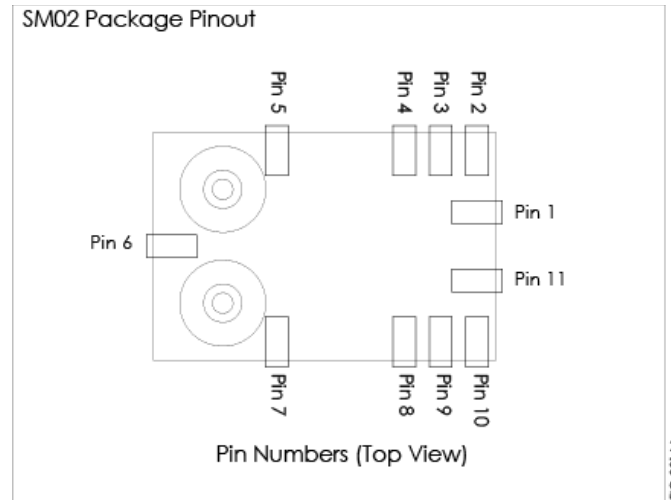

11.4 Reflow Soldering and Handling Conditions

Parameter	Sym	Val	Units
Soldering Specifications (Max)			
Preheat Ramp Rate	t _{PHRR}	3	°C/s
Soak Time	t _{SOAK}	3	min
Time Above 217C	t _{GT217}	50	s
Time Above 230C	t _{GT230}	40	s
Time Above 250C	t _{GT250}	15	s
Peak Temperature	t _{PT}	255	°C
Cooling Ramp Rate	t _{CRR}	-4	°C/s
Weight	W _{PRT}	3.5	gm
Moisture Sensitivity	MSL	3	
ESD (Human Body Model)	ESD	2	kV

11.5 Pick and Place Pick-up Zone

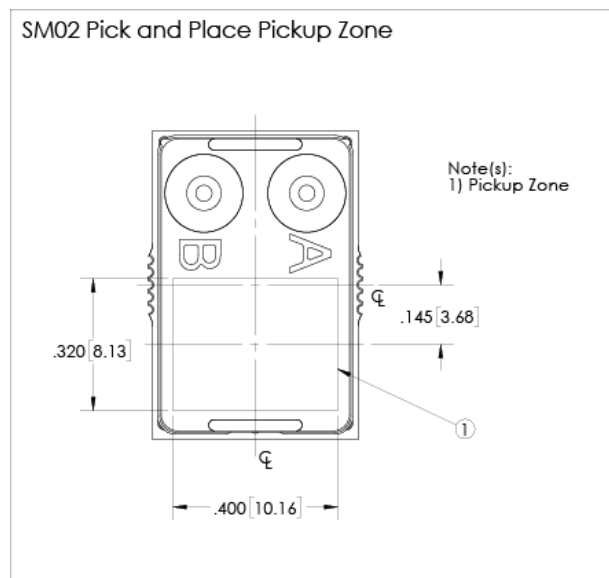

11.6 Packaging Options

11.6.1 Tray Packaging

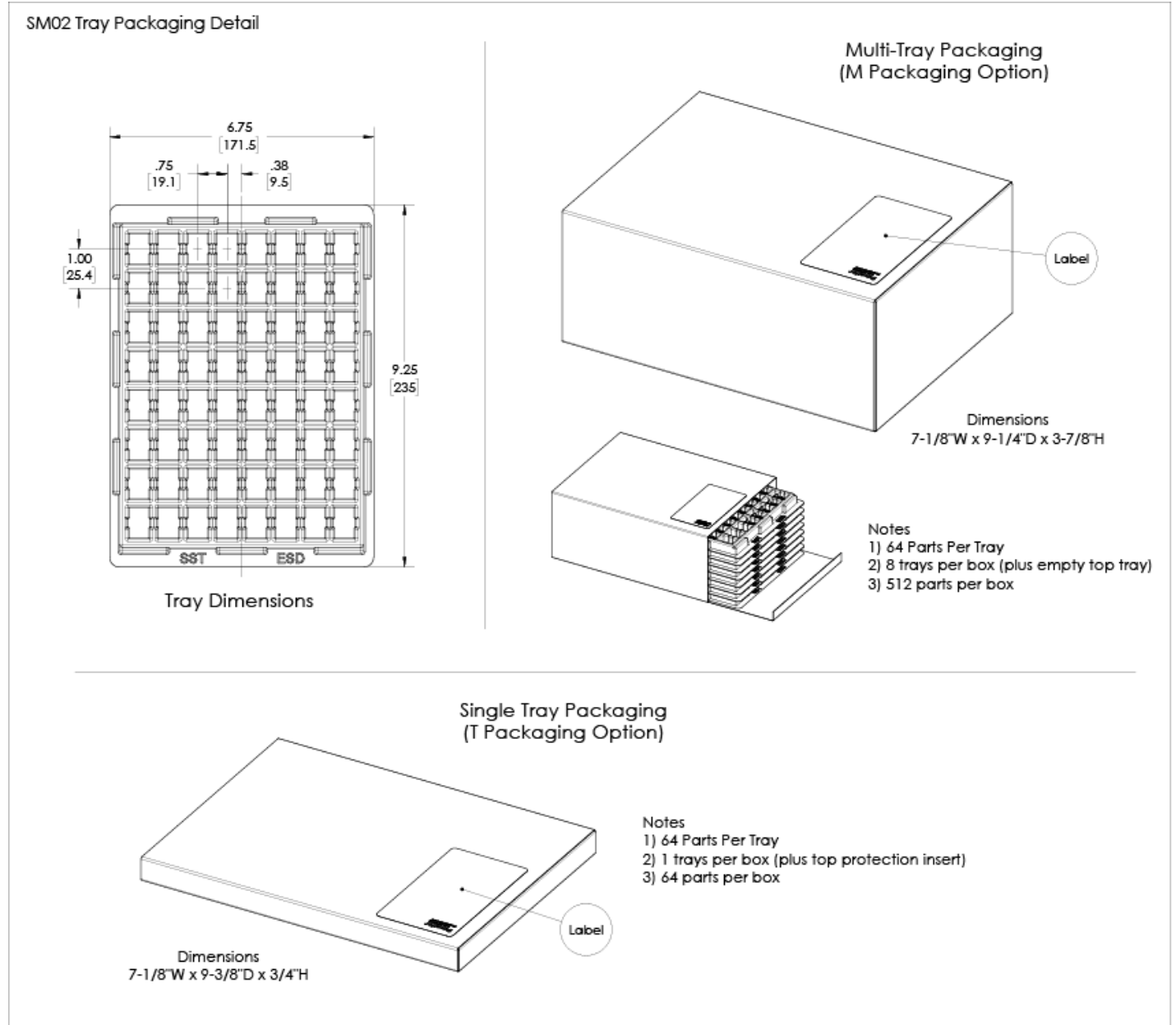
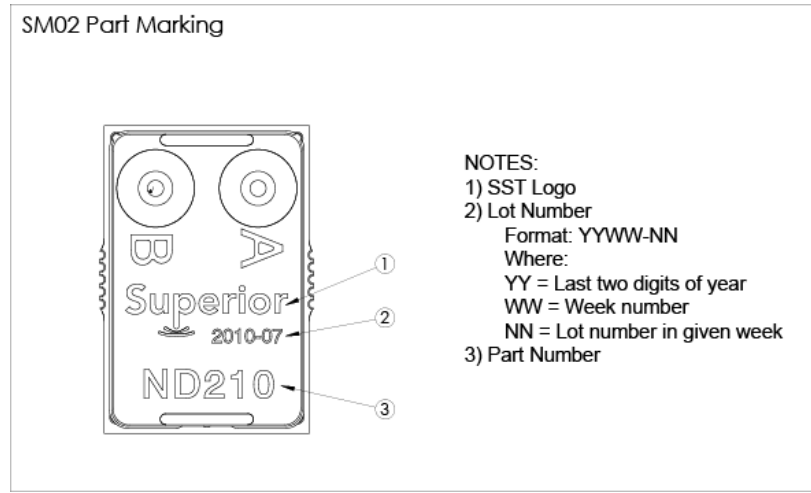

FIG-002.2B

11.7 Part Identification



12 Packaging Labeling

Packaging labels are provided with barcode Code 128 symbology. The provided fields are Company Name, Part Number, Packaging ID and Quantity. The Packaging ID traces back to the Lot Number (or Lot Numbers) contained in the package. The purpose is to eliminate multiple labels (one for each included Lot Number) in the event of multiple Lot Numbers within a single package. This is for ease of customer tracking and maintenance. The Packaging ID is a 24 bit value printed in hexadecimal format.

13 Ordering Information

Part Number	Part Package	Packaging	Packaging Qty	Order Number
ND210-SM02	SM02	Tape and Reel	256	ND210-SM02-R
		Multi-Tray	512	ND210-SM02-M
		Single Tray	64	ND210-SM02-T
		Cut Tape	1-63	ND210-SM02-C
ND110-SM02	SM02	Tape and Reel	256	ND110-SM02-R
		Multi-Tray	512	ND110-SM02-M
		Single Tray	64	ND110-SM02-T
		Cut Tape	1-63	ND110-SM02-C
ND120-SM02	SM02	Tape and Reel	256	ND120-SM02-R
		Multi-Tray	512	ND120-SM02-M
		Single Tray	64	ND120-SM02-T
		Cut Tape	1-63	ND120-SM02-C
ND130-SM02	SM02	Tape and Reel	256	ND130-SM02-R
		Multi-Tray	512	ND130-SM02-M
		Single Tray	64	ND130-SM02-T
		Cut Tape	1-63	ND130-SM02-C
ND005D-SM02	SM02	Tape and Reel	256	ND005D-SM02-R
		Multi-Tray	512	ND005D-SM02-M
		Single Tray	64	ND005D-SM02-T
		Cut Tape	1-63	ND005D-SM02-C

14 Revisions

Rev	Change Description(s)	Date	By
A	Initial Release	1/4/21	T.S.

15 Warranty

Superior Sensor Technology and its subsidiaries warrant goods of its manufacture as being free of defective materials and faulty workmanship during the applicable warranty period. In all cases, Superior Sensor Technology's standard product warranty applies; please refer to your order acknowledgement or consult your local sales office for specific warranty details.

If warranted goods are returned to Superior Sensor Technology during the period of coverage, Superior Sensor Technology will repair or replace, at its option, without charge those items that Superior Sensor Technology, in its sole discretion, finds defective. **The foregoing is buyer's sole remedy and is in lieu of all other warranties, expressed or implied. In no event shall Superior Sensor Technology be liable for consequential, special, or indirect damages.**

While Superior Sensor Technology may provide application assistance personally, through literature or the Superior Sensor Technology web site, it is buyer's sole responsibility to determine the suitability of the product in their application. Superior Sensor Technology assumes no liability for applications assistance or customer product design.

Superior Sensor Technology reserves the right to make corrections, modifications, enhancements, improvements and other changes to its products and services at any time and to discontinue any product or service without notice. Customers should obtain the latest relevant information before placing orders and should verify that such information is current and complete.

CODICO GmbH

Zwingenstrasse 6-8
2380 Perchtoldsdorf, Austria
Tel: +43 1 86 305-0
Fax: +43 1 86 305-5000
office@codico.com
www.codico.com

Superior SENSOR TECHNOLOGY

3080 Oakmead Village Road
Santa Clara, CA 95051
www.SuperiorSensors.com
info@SuperiorSensors.com
+1.408.703.2950

NimbleSense is a trademark of Superior Sensor Technology