

Rambutan is a dual-band (2.4 or 5 GHz) module with a fast 720 MHz CPU and 128 MB of RAM and Flash

Rambutan is based on QCA 9557 or 9550 SoC and comes in two temperature ranges: commercial* (Rambutan) and industrial** (Rambutan-I).

It is a surface mountable, dual-sided, Wi-Fi enabled Linux module.

Dual-band radio (2.4 or 5 GHz), powerful 720 MHz CPU, 300 Mbps data-rate, 128 MB RAM and Flash and a development kit with multiple interfaces (e.g. Gigabit Ethernet port, PCIe, hardware SPI etc.) are the main advantages of the Rambutan module.

OpenWRT linux distribution source code is available on GitHub <https://github.com/8devices> and is supported by our growing community on <http://www.8devices.com/community> forum.

*Commercial temperature range: 0 - 65° C

**Industrial temperature range: -40 - 85° C

Quick specs

- 802.11 a/b/g/n, 2.4 or 5 GHz, 2x2 MIMO, 300 Mbps data rate, 21 dBm per chain output power
- U.FL connectors for external antenna
- 128 MB FLASH, 128 MB DDR2 RAM
- Linux friendly , OpenWRT flash image and source code are available for download on www.8devices.com/wiki Rambutan
- CPU – QCA 9557 or 9550 (720 MHz)
- 32 by 47 mm size
- Surface mountable, dual-side design
- Industrial and commercial temperature range models
- Available interfaces - 2 x USB 2.0, 2 x serial port, 1 x 100 Base-T Ethernet port (2nd 1000 Base-T Ethernet port on the Rambutan-DVK is connected to the module using SGMII interface), I2S, SPI, I2C, PCIe, GPIO, MDIO

Module dimensions

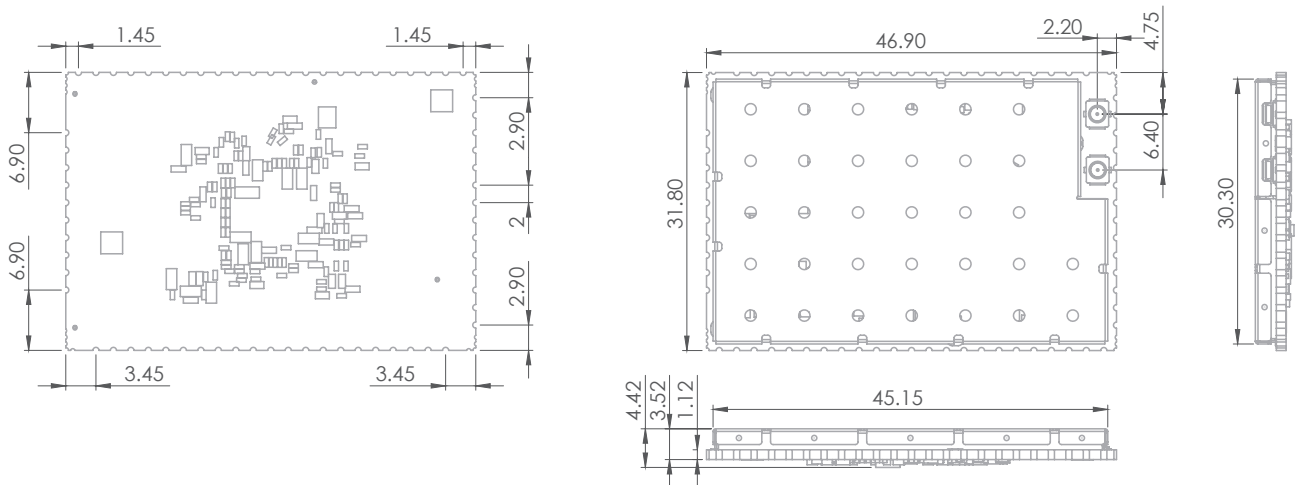

Block diagram

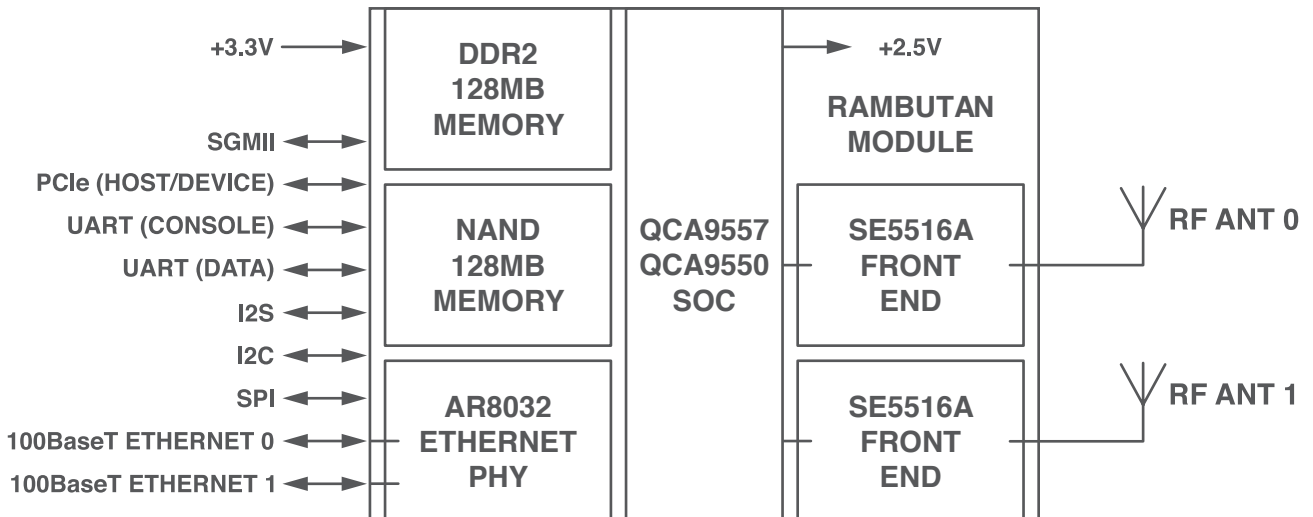

Development kit

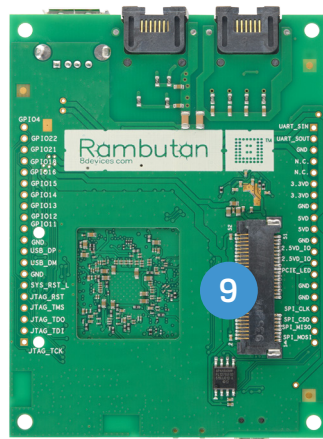
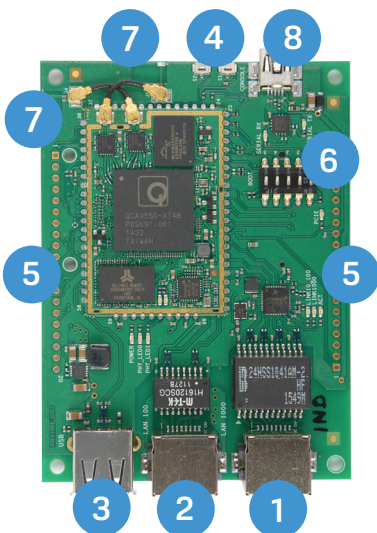

- 1 - 1000 Base-T Ethernet port
- 2 - 100 Base-T Ethernet port
- 3 - USB Type-A socket
- 4 - Buttons: S1 - reset, S2 - programmable (GPIO connected)
- 5 - 2.45 mm pitch connector holes
- 6 - DIP switch for bootstrap options
- 7 - Two integrated antennas
- 8 - Mini USB Type-A socket (console + power)
- 9 - Mini PCIe socket

Module pinout

