



晶采光電科技股份有限公司
AMPIRE CO., LTD.

SPECIFICATIONS FOR LCD MODULE

CUSTOMER	
CUSTOMER PART NO.	
AMPIRE PART NO.	AM-19201200B1TZQW-T03
APPROVED BY	
DATE	

- Approved For Specifications
 Approved For Specifications & Sample

AMPIRE CO., LTD.

**4F., No.116, Sec. 1, Xintai 5th Rd., Xizhi Dist., New Taipei
City221, Taiwan (R.O.C.)**

新北市汐止區新台五路一段 116 號 4 樓(東方科學園區 A 棟)

TEL:886-2-26967269 , FAX:886-2-26967196 or 26967270

APPROVED BY	CHECKED BY	ORGANIZED BY

RECORD OF REVISION

Revision Date	Page	Contents	Editor
2015/12/7	--	New Release	Patrick
2016/4/28		Update SPEC	Alan

1. General Descriptions

1.1 Introduction

The LCM is a color active matrix TFT LCD module using amorphous silicon TFT's (Thin Film Transistors) as an active switching devices. This module has a 10.1 inch diagonally measured active area with WUXGA resolutions (1920 horizontal by 1200 vertical pixel array). Each pixel is divided into RED, GREEN, BLUE dots which are arranged in vertical Stripe and this module can display 16.7M colors. The TFT-LCD panel used for this module is a low reflection and higher color type.

1.2 Features

- 3.3 V Logic Power
- LVDS (2ch) Interface for 1920RGB x 1200 resolution.
- 16.7M Colors (6bit + HFRC)
- Data Enable Signal Mode
- Green Product (RoHS)
- Projective Capacitive Touch panel (USB Interface).

1.3 Product Summary

Items	Specifications	Unit
Screen Diagonal	10.1	Inch
Active Area	216.806(H) x 135.504(V)	mm
Pixel Format	1920 (H) x RGB x 1200 (V)	-
Pixel Pitch	0.1129 (H) × 0.1129 (V)	mm
Pixel Arrangement	R.G.B. Vertical Stripe	-
Display Mode	Normally Black	-
White Luminance	850 (Typ)	cd /m2
Contrast Ratio	800 : 1 (Typ)	-
Input Voltage	3.3	V
Outline Dimensions	232.65 (H) x 155.2 (V) x 10.41 (D)	mm
Support Color	16.7M (6bit + HFRC)	-

2. Absolute Maximum Ratings

ITEM	SYMBOL	VALUES		UNIT	REMARK
		MIN	MAX		
Logic/LCD Driver Voltage	V _{in}	-0.3	+4.5	V	
Operation Temperature	T _{op}	-20	70	°C	
Storage Temperature	T _{st}	-30	80	°C	

3. Electrical Specifications

3.1 Electrical Specifications

Parameter		Min	Typ.	Max.	Unit	Note
LCD Logic Power Supply Voltage	V _{DD}	3.0	3.3	4.2	V	
LCD Logic Power Supply Current	I _{DD}	-	T.B.D	-	mA	Note1 V _{dd} =3.3V,25°C
LED Driver Power Voltage	V _{LED}	-	12	-	V	
LED Driver Current	I _{LED}	-	900	-	mA	
Back-light LED Voltage	V _{BL}	-	22	24	V	
Back-light LED Current	I _{BL}	-	360	-	mA	
PWM Frequency for LED Driver	LED_PWM	100	-	20	KHz	
I _{Rush} Current				T.B.D	mA	Note3.

Note1 : The supply voltage is measured and specified at the interface connector of LCM.
(Test Pattern : White)

Note2 : PBL is calculated value for reference. This value is without LED driver efficiency .

Note3:

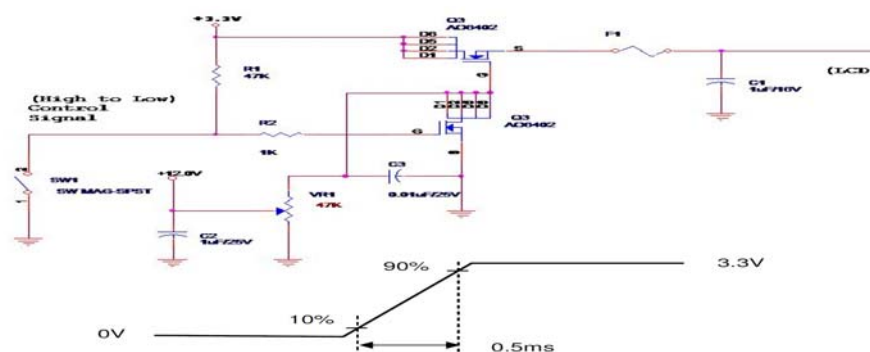

3.2 CMOS/TTL DC Specifications

The power specification are measured under 25°C and frame frequency under 60Hz.

Symbol	Parameter	Conditions	Min.	Typ	Max	Units
V _{IH}	High Level Input Voltage	/PDWN, MODE[2:0]	2.0		V _{CC}	V
V _{IL}	Low Level Input Voltage	R/F, OE, MAP Pin	GND		0.8	V
V _{OH}	High Level Output Voltage	I _{OH} = -8mA	2.4			V
V _{OL}	Low Level Output Voltage	I _{OL} = 8mA			0.4	V

Note (1) Maximum Measurement Condition : White Pattern at 3.3V driving voltage.
(P_{max}=V_{3.3} x I_{white})

4 Interface Timings

4.1 Timing Characteristics

Parameter		Symbol	Min.	Typ.	Max.	Unit
Frame Rate		---	---	60	---	Hz
Clock frequency		$1/T_{\text{Clock}}$	---	150	---	MHz
Vertical Section	Period	T_V	---	1212	---	T_{Line}
	Active	T_{VD}	1200			
	Blanking	T_{VB}	---	12	---	
Horizontal Section	Period	T_H	---	2058	---	T_{Clock}
	Active	T_{HD}	1920			
	Blanking	T_{HB}	---	138	---	

4.2 Timing diagram

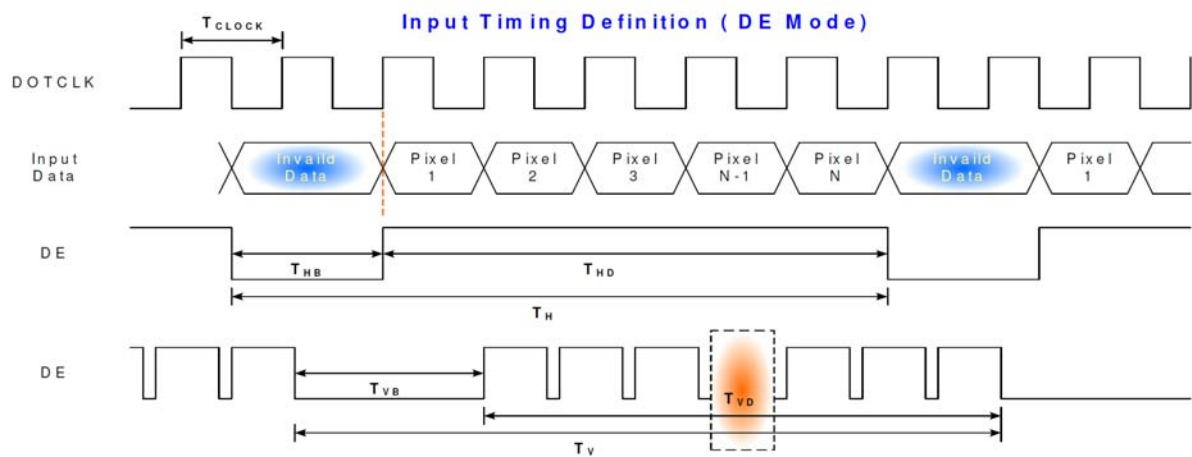

4.3 AC Timing Diagrams

V_{CC}=VCC=PVCC=LVCC=CVCC

Symbol	Parameter		Min.	Typ.	Max.	Units
t _{RCP}	CLKOUT Period (Fig4)		6.67	T	250	ns
t _{RCH}	CLKOUT High Time (Fig4)			$\frac{T}{2}$		ns
t _{RCL}	CLKOUT Low Time (Fig4)			$\frac{T}{2}$		ns
t _{DOUT}	TTL Data OUT Period (Fig5,6)		6.67	T	250	ns
t _{RS}	TTL Data Setup to CLKOUT(Fig5,6)		0.45t _{DOUT} -0.45			ns
t _{RH}	TTL Data Hold to CLKOUT(Fig5,6)		0.45t _{DOUT} -0.45			ns
t _{TLH}	TTL Low to High Transition Time (Fig 3)			0.7	1.0	ns
t _{THL}	TTL High to Low Transition Time (Fig 3)			0.7	1.0	ns
t _{SK}	Receiver Skew Margin (Fig7)	t _{RCIP} =65MHz	-650	0	650	ps
		t _{RCIP} =85MHz	-450	0	450	ps
		t _{RCIP} =108MHz	-250	0	250	ps
		t _{RCIP} =135MHz	-170	0	170	ps
t _{RIP1}	Input Data Position0 (Fig7)		-t _{SK}	0	+t _{SK}	ns
t _{RIP0}	Input Data Position1 (Fig7)		$\frac{t_{RCIP}}{7} - t_{SK}$	$\frac{t_{RCIP}}{7}$	$\frac{t_{RCIP}}{7} + t_{SK}$	ns
t _{RIP6}	Input Data Position2 (Fig7)		$2\frac{t_{RCIP}}{7} - t_{SK}$	$2\frac{t_{RCIP}}{7}$	$2\frac{t_{RCIP}}{7} + t_{SK}$	ns
t _{RIP5}	Input Data Position3 (Fig7)		$3\frac{t_{RCIP}}{7} - t_{SK}$	$3\frac{t_{RCIP}}{7}$	$3\frac{t_{RCIP}}{7} + t_{SK}$	ns
t _{RIP4}	Input Data Position4 (Fig7)		$4\frac{t_{RCIP}}{7} - t_{SK}$	$4\frac{t_{RCIP}}{7}$	$4\frac{t_{RCIP}}{7} + t_{SK}$	ns
t _{RIP3}	Input Data Position5 (Fig7)		$5\frac{t_{RCIP}}{7} - t_{SK}$	$5\frac{t_{RCIP}}{7}$	$5\frac{t_{RCIP}}{7} + t_{SK}$	ns
t _{RIP2}	Input Data Position6 (Fig7)		$6\frac{t_{RCIP}}{7} - t_{SK}$	$6\frac{t_{RCIP}}{7}$	$6\frac{t_{RCIP}}{7} + t_{SK}$	ns
t _{RPLL}	Phase Lock Loop Set (Fig8)				10.0	ms
t _{RCD}	RCLK +/- to CLK OUT Delay (Fig9) MODE<1:0>=LL DK=L, 75MHz		89.7		94	ns
t _{RCIP}	CLKIN Period (Fig7)		7.4		125.0	ns
t _{DEINT}	MODE<1:0>=HL (Single IN/ Dual OUT Mode) Only	DE input period (Fig9-1)	4t _{RCIP}	t _{RCIP} *(2n) n= integer		ns
t _{DEH}		DE input High time (Fig9-1)	2t _{RCIP}			ns
t _{DEL}		DE input Low time (Fig9-1)	2t _{RCIP}			ns

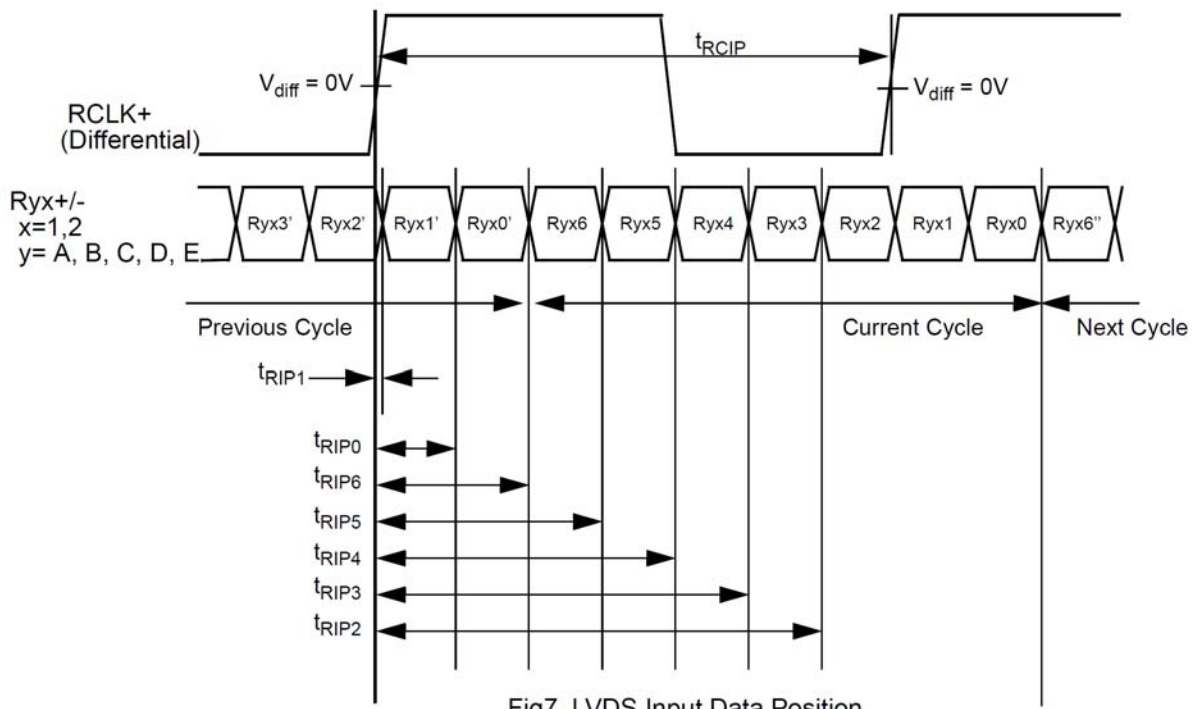
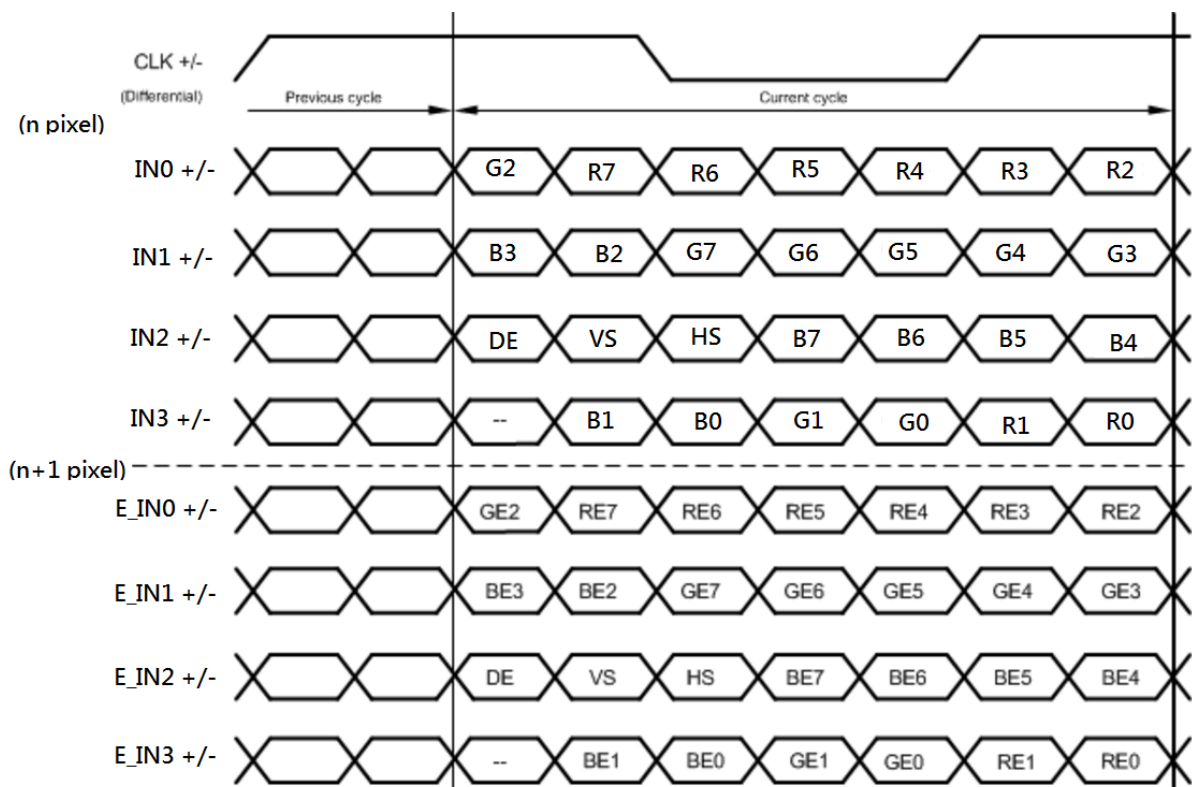

Fig7. LVDS Input Data Position

4.4 Timing Diagram of Interface Signal



4.6 Power Sequence

To prevent a latch-up or DC operation of the LCD module, the power on/off sequence shall be as shown below.

VDD power and LED on/off sequence are as follows. Interface signals are also shown in the chart. Signal shall be Hi-Z state or low level when VDD is off.

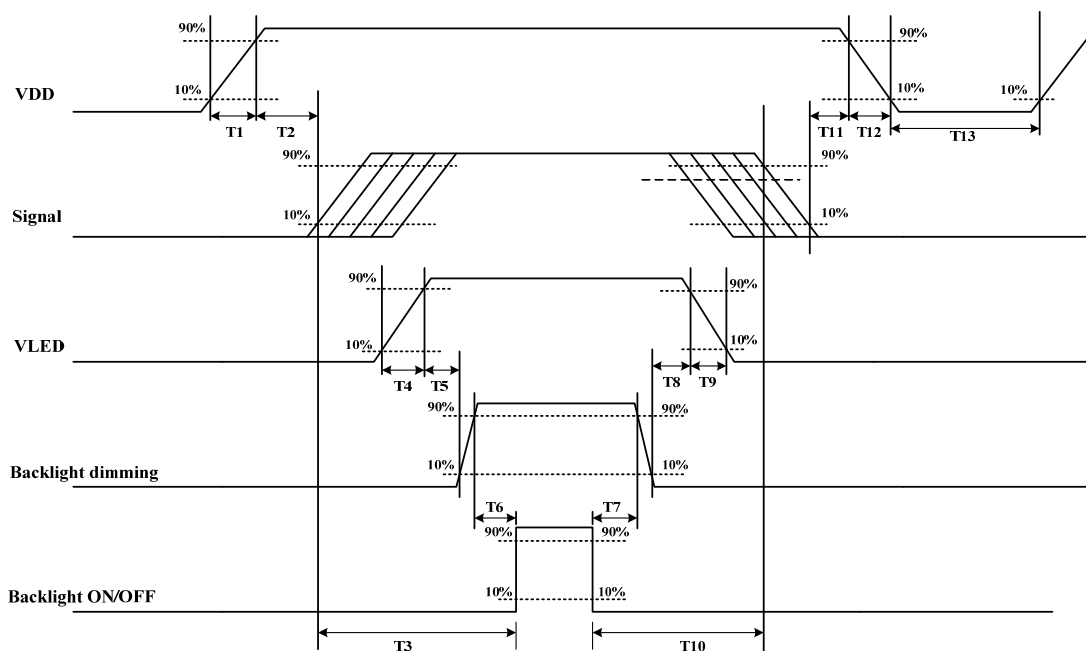

Parameter	Value			Units
	Min.	Typ.	Max.	
T1	0.5	-	10	[ms]
T2	0	40	50	[ms]
T3	200	-	-	[ms]
T4	0.5	-	10	[ms]
T5	10	-	-	[ms]
T6	10	-	-	[ms]
T7	0	-	-	[ms]
T8	10	-	-	[ms]
T9	-	-	10	[ms]
T10	110	-	-	[ms]
T11	0.5	16	50	[ms]
T12	-	-	100	[ms]
T13	1000	-	-	[ms]

5. Optical Specifications

The optical characteristics are measured under stable conditions as following notes

Item	Conditions		Min.	Typ.	Max.	Unit	Note
Viewing Angle (CR>10)	Horizontal	θ_L	80	85	-	degree	Note1
		θ_R	80	85	-		
	Vertical	θ_T	80	85	-		
		θ_B	80	85	-		
Contrast Ratio	Center		600	800	-	-	Note2
Response Time	Rising + Falling		-	25	35	ms	Note5
Color Chromaticity (CIE1931)	Red	x	Typ. -0.05	0.593	Typ. +0.05	-	Note3
	Red	y		0.341		-	
	Green	x		0.324		-	
	Green	y		0.589		-	
	Blue	x		0.154		-	
	Blue	y		0.123		-	
	White	x		0.313		-	
	White	y		0.329		-	
White Luminance	Center		680	850	-	cd/m ²	Note4
Luminance Uniformity	9Points		75	-	-	%	Note4
Cross Talk	CT	$\Theta=0$	-	-	2.0	%	Note6

Notes 1 : Viewing angle is the angle at which the contrast ratio is greater than 10.

The viewing angles are determined for the horizontal or 3, 9 o'clock direction and the vertical or 6, 12 o'clock direction with respect to the optical axis which is normal to the LCD surface(see Figure1).

Notes 2 : Contrast measurements shall be made at viewing angle of $\Theta=0$ and at the center of the LCD surface. Luminance shall be measured with all pixels in the view field set first to white, then to the dark (black) state (see Figure1).

Luminance Contrast Ratio (CR) is defined mathematically as CR = Luminance when displaying a white raster / Luminance when displaying a black raster.

Notes 3 : Reference only / Standard Front Surface Treatment Measured with green cover glass. The color chromaticity coordinates specified in Table 4 shall be calculated from the spectral data measured with all pixels first in red, green, blue and white. Measurements shall be made at the center of the panel.

Figure 1. Measurement Set Up

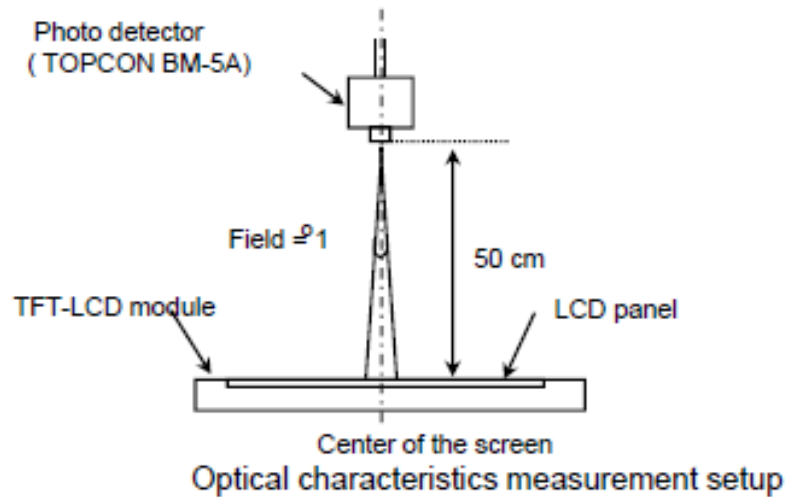
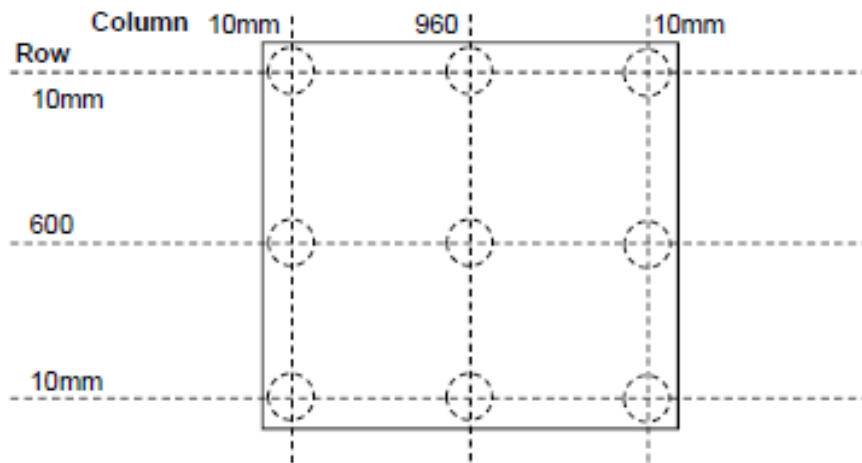

Figure 2. White Luminance and Uniformity Measurement Locations (9 points)



Note 4.

Luminance of white is defined as luminance values of 9 points across the LCD surface. Luminance shall be measured with all pixels in the view field set first to white. This measurement shall be taken at the locations shown in Figure 2 for a total of the measurements per display.

• $Y_w = (\text{Sum of 9 Points Luminance} / 9)$

• $\Delta Y_9 = (\text{Min Luminance of 9 points} / \text{Max luminance of 9 point}) * 100\%$

* LED Condition = (Duty Ratio 100%, LED current 20.0mA)

Figure 3. Response Time Testing

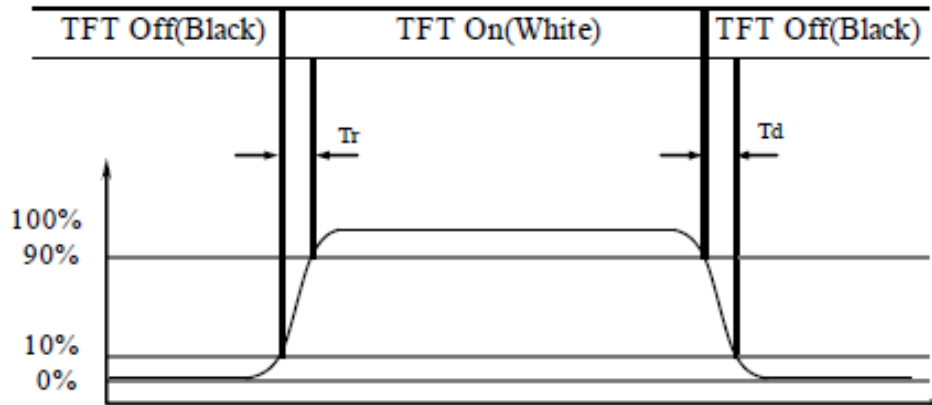

Note 5.

The electro-optical response time measurements shall be made as Figure 4 by switching the "data" input signal ON and OFF. The times needed for the luminance to change from 10% to 90% is T_r , and 90% to 10% is T_d .

Note 6.

Cross-Talk of one area of the LCD surface by another shall be measured by comparing the luminance (Y_A) of a 25mm diameter area, with all display pixels set to a gray level, to the luminance (Y_B) of that same area when any adjacent area is driven dark (Refer to Figure 4).

Figure 4. Cross Modulation Test Description

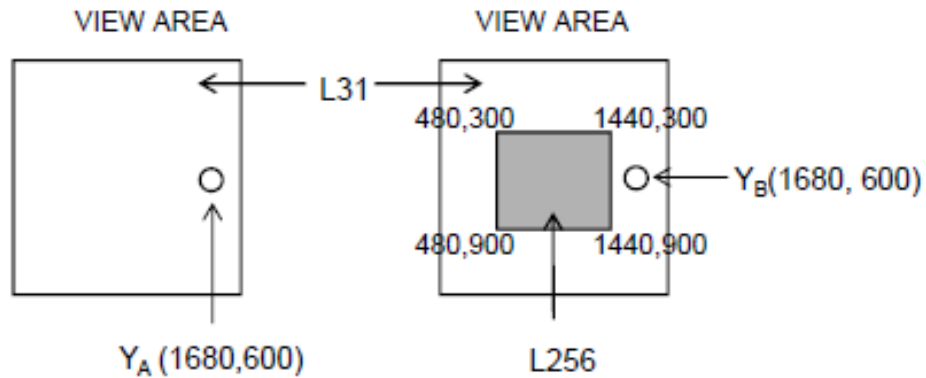

$$\text{Cross-Talk (\%)} = \left| \frac{Y_B - Y_A}{Y_B} \right| \times 100$$

Where:

Y_A = Initial luminance of measured area (cd/m^2)

Y_B = Subsequent luminance of measured area (cd/m^2)

The location measured will be exactly the same in both patterns

6. Interface Connections

6.1 Electrical Interface Connection

Pin #	Signal Name	Description
1	GND	Ground
2	NC	Not Connect
3	VDD	Power Supply, 3.3V (typical)
4	VDD	Power Supply, 3.3V (typical)
5	GND	Ground
6	GND	Ground
7	NC	Not Connect
8	NC	Not Connect
9	GND	Ground
10	IN0-	-LVDS differential data input
11	IN0+	+LVDS differential data input
12	IN1-	-LVDS differential data input
13	IN1+	+LVDS differential data input
14	IN2-	-LVDS differential data input
15	IN2+	+LVDS differential data input
16	CLK-	-LVDS differential data input
17	CLK+	+LVDS differential data input
18	IN3-	-LVDS differential data input
19	IN3+	+LVDS differential data input
20	E_IN0-	-LVDS differential data input
21	E_IN0+	+LVDS differential data input
22	E_IN1-	-LVDS differential data input
23	E_IN1+	+LVDS differential data input
24	E_IN2-	-LVDS differential data input
25	E_IN2+	+LVDS differential data input
26	E_CLK-	-LVDS differential data input
27	E_CLK+	+LVDS differential data input
28	E_IN3-	-LVDS differential data input
29	E_IN3+	+LVDS differential data input
30	GND	Ground
31	GND	Ground
32	VLED	LED Power Supply (12V)

33	VLED	LED Power Supply (12V)
34	VLED	LED Power Supply (12V)
35	VLED	LED Power Supply (12V)
36	LED_EN	LED Enable Pin : Hig→Enable (Typ : 3.3V)
37	LED_PWM	PWM Signal for LED Dimming Control
38	GND	Ground
39	GND	Ground
40	GND	Ground

6.2 Data Input Format

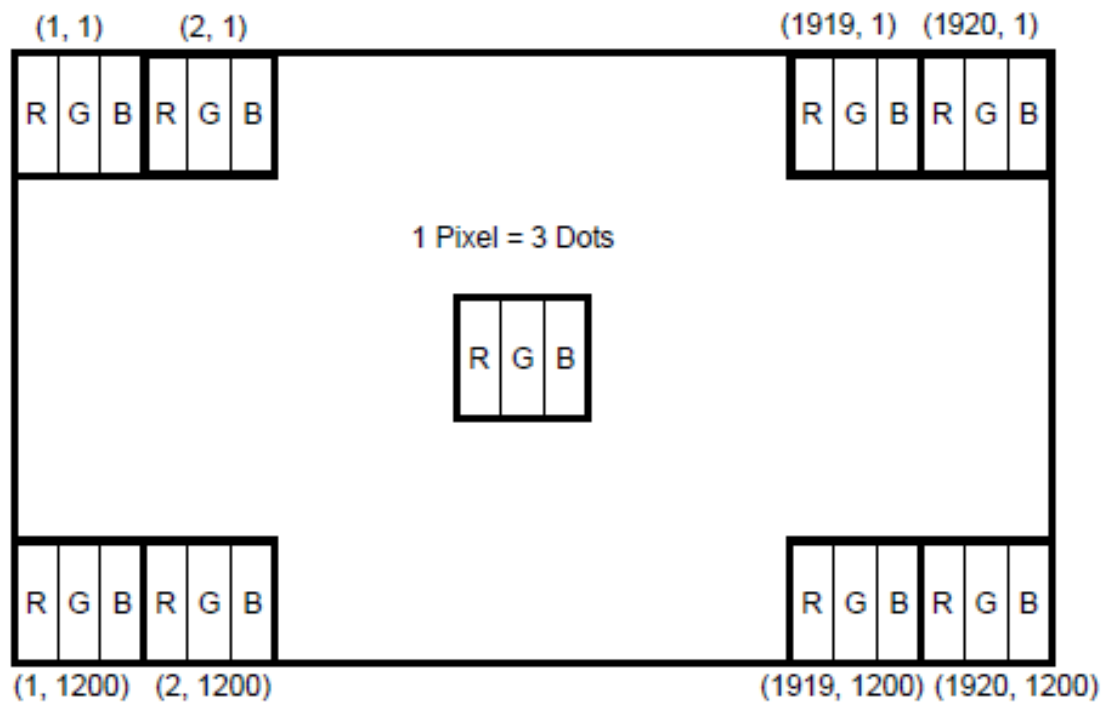

7. LED Driving Conditions

ITEM	SYMBOL	MIN	TYP	MAX	UNIT	CONDITION
LED Backlight Voltage	V_{BL}	--	22	24	V	For reference
LED Backlight Current	I_{BL}	-	360	--	mA	$T_a=25^{\circ}\text{C}$
LED Life Time		--	50K	-	KHr	Note*

Note* : Brightness to be decreased to 50% of the initial value. $T_a=25^{\circ}\text{C}$

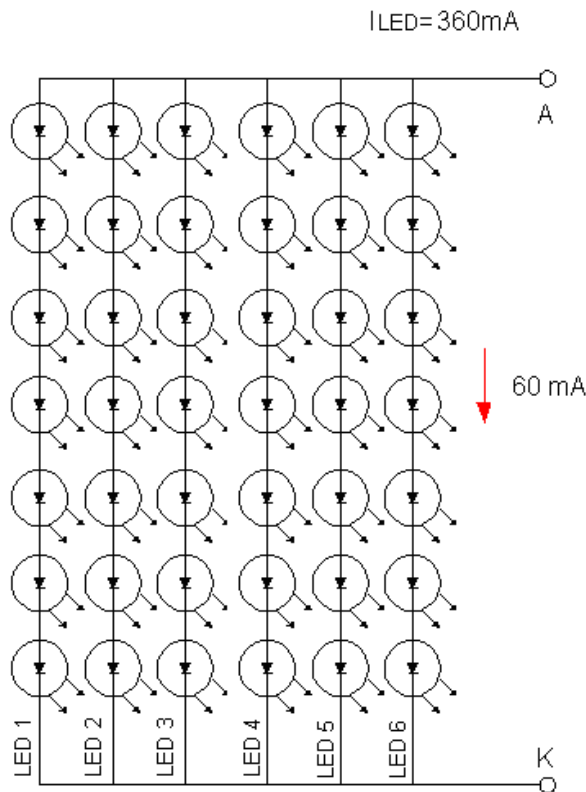

When LCM is operated over 40°C ambient temperature, the I_{LED} should be follow :

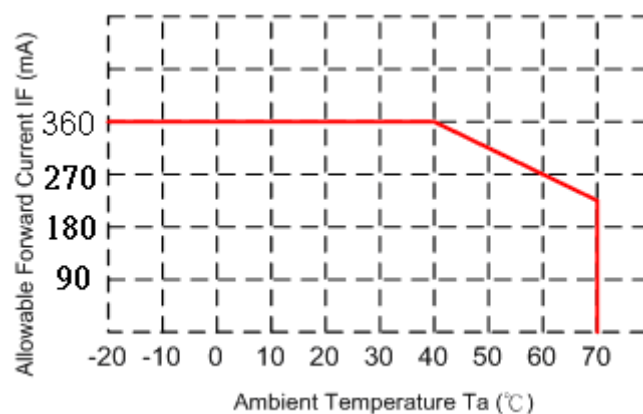

8. Projected capacitive-type Touch panel specification

8.1 Basic Characteristic

ITEM	SPECIFICATION
Type	Projective Capacitive Touch Panel
Activation	Two-fingers or Signal-finger
X/Y Position Reporting	Absolute Position
Touch Force	No contact pressure required
Calibration	No need for calibration
Report Rate	Approx 100 points/sec
Control IC	EETI EXC3000

ITEM	Symbol	MIN	TYP	MAX	UNIT
Touch panel power supply	VDD	4.75	5	5.25	V
Touch panel power supply current at Normal operation mode	I _{VDD}	--	45(Reference)	--	mA
Touch panel power supply current at USB suspend mode	I _{VDD}	--	TBD	--	uA

8.2 Interface

CN6		
Pin No.	Symbol	Function
1	VDD	USB POWER 5V
2	D+	USB Data+
3	D-	USB Data-
4	NC	No connect
5	GND	GND
6	GND	GND

9. ELIABILITY TEST CONDITIONS

Test Item	Test Conditions	Note
High Temperature Operation	70±3°C ,Dry t=240 hrs	
Low Temperature Operation	-20±3°C, Dry t=240 hrs	
High Temperature Storage	80±3°C , Dry t=240 hrs	1,2
Low Temperature Storage	-30±3°C ,Dry t=240 hrs	1,2
Thermal Shock Test	-20°C ~ 25°C ~ 60°C 30 m in. 5 min. 30 min. (1 cycle) Total 100 cycle(Dry)	1,2
Storage Humidity Test	60 °C, Humidity 90%, 240 hrs	1,2
Vibration Test (Packing)	Sweep frequency : 10 ~ 55 ~ 10 Hz/1min Amplitude : 0.75mm Test direction : X.Y.Z/3 axis Duration : 30min/each axis	2

Note 1 : Condensation of water is not permitted on the module.

Note 2 : The module should be inspected after 1 hour storage in normal conditions (15-35°C , 45-65%RH).

Definitions of life end point :

- Current drain should be smaller than the specific value.
- Function of the module should be maintained.
- Appearance and display quality should not have degraded noticeably.
- Contrast ratio should be greater than 50% of the initial value.

10 . GENERAL PRECAUTION

10.1 Use Restriction

This product is not authorized for use in life supporting systems, aircraft navigation control systems, military systems and any other application where performance failure could be life-threatening or otherwise catastrophic.

10.2 Disassembling or Modification

Do not disassemble or modify the module. It may damage sensitive parts inside LCD module, and may cause scratches or dust on the display. AMPIRE does not warrant the module, if customers disassemble or modify the module.

10.3 Breakage of LCD Panel

- (1) If LCD panel is broken and liquid crystal spills out, do not ingest or inhale liquid crystal, and do not contact liquid crystal with skin.
- (2) If liquid crystal contacts mouth or eyes, rinse out with water immediately.
- (3) If liquid crystal contacts skin or cloths, wash it off immediately with alcohol and rinse thoroughly with water.
- (4) Handle carefully with chips of glass that may cause injury, when the glass is broken.

10.4 Electric Shock

- (1) Disconnect power supply before handling LCD module.
- (2) Do not pull or fold the LED cable.
- (3) Do not touch the parts inside LCD modules and the fluorescent LED's connector or cables in order to prevent electric shock.

10.5 Absolute Maximum Ratings and Power Protection Circuit

- (1) Do not exceed the absolute maximum rating values, such as the supply voltage variation, input voltage variation, variation in parts' parameters, environmental temperature, etc., otherwise LCD module may be damaged.
- (2) Please do not leave LCD module in the environment of high humidity and high temperature for a long time.
- (3) It's recommended to employ protection circuit for power supply.

10.6 Operation

- (1) Do not touch, push or rub the polarizer with anything harder than HB pencil lead.
- (2) Use fingerstalls of soft gloves in order to keep clean display quality, when persons handle the LCD module for incoming inspection or assembly.
- (3) When the surface is dusty, please wipe gently with absorbent cotton or other soft material.
- (4) Wipe off saliva or water drops as soon as possible. If saliva or water drops contact with polarizer for a long time, they may cause deformation or color fading.
- (5) When cleaning the adhesives, please use absorbent cotton wetted with a little petroleum benzene or other adequate solvent.

10.7 Mechanism

Please mount LCD module by using mounting holes arranged in four corners tightly.

10.8 Static Electricity

- (1) Protection film must remove very slowly from the surface of LCD module to prevent from electrostatic occurrence.
- (2) Because LCD modules use CMOS-IC on circuit board and TFT-LCD panel, it is very weak to electrostatic discharge. Please be careful with electrostatic discharge. Persons who handle the module should be grounded through adequate methods.

10.9 Strong Light Exposure

The module shall not be exposed under strong light such as direct sunlight. Otherwise, display characteristics may be changed.

10.10 Disposal

When disposing LCD module, obey the local environmental regulations.

10.11 Others

Do not keep the LCD at the same display pattern continually. The residual image will happen and it will damage the LCD. Please use screen saver.

REV	REVISION RECORD	DATE	NAME
0	NEW RELEASE	12-04-15	EMILY
1	Modify Interface Pin 26 & 27 to NC	03-21-16	EMILY

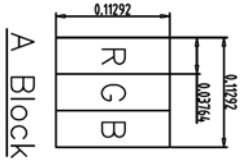

1	GND	21	E_IN0+
2	NC	22	E_IN1-
3	VDD	23	E_IN1+
4	VDD	24	E_IN2-
5	GND	25	E_IN2+
6	GND	26	NC
7	NC	27	NC
8	NC	28	E_IN3-
9	GND	29	E_IN3+
10	GND	30	GND
11	IN0+	31	GND
12	IN1-	32	VLED
13	IN1+	33	VLED
14	IN2-	34	VLED
15	IN2+	35	VLED
16	CLK-	36	LED_EN
17	CLK+	37	LED_PWM
18	IN3-	38	GND
19	IN3+	39	GND
20	E_IN0-	40	GND

1	VDD
2	D+
3	D-
4	NC
5	GND
6	GND

Note:
1. Unless indicated, Tolerance "±0.5"

- UV Glue For OLB Protection.
- LVDS Connector: LS050-W40B-H10-G or Equivalent.

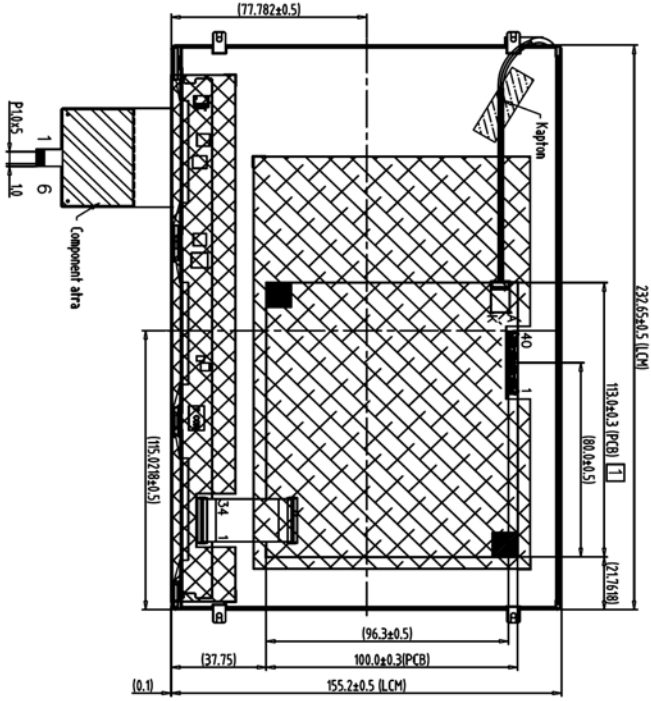

Back View

ITEM NO.	DESCRIPTION	TOLERANCE	GRADE	QTY	UNIT	DATE	NAME	DATE	NAME
1	1280800N1+1280800N4 TP(USB)			7		12-04-15	EMILY		
2	CTP:P1.0 6PIN/GSA10-06-P-R			8					
3				9					
4				10					
5				11					
6				12					

REV	DATE	NAME	DESCRIPTION
0	12-04-15	EMILY	NEW RELEASE
1	03-21-16	EMILY	Modify Interface Pin 26 & 27 to NC

晶采光电科技
 TITLE: 19201200B1-T03
 DWG. NO.: *151230MB
 SHEET 1 OF 1