

ZLQ SERIES

NEW

105°C Ultra Miniaturized, Low Impedance.

◆FEATURES

- Achieved miniaturization of ZLH series, as well as high frequency impedance reduction.
- Load Life : 105°C 3000~6000 hours.
- RoHS compliance.

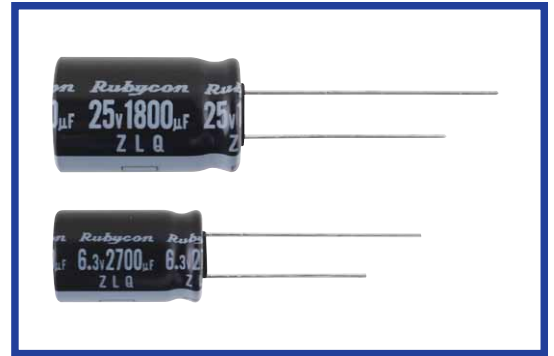

◆SPECIFICATIONS

Items	Characteristics																					
Category Temperature Range	-40~+105°C																					
Rated Voltage Range	6.3~35V.DC																					
Capacitance Tolerance	±20% (20°C, 120Hz)																					
Leakage Current(MAX)	I=0.03CV or 3µA whichever is greater.(After 2 minutes) I=Leakage Current(µA) C=Capacitance(µF) V=Rated Voltage(V)																					
Dissipation Factor(MAX) (tanδ)	<table border="1"> <tr> <td>Rated Voltage (V)</td> <td>6.3</td> <td>10</td> <td>16</td> <td>25</td> <td>35</td> <td>(20°C, 120Hz)</td> </tr> <tr> <td>tanδ</td> <td>0.22</td> <td>0.19</td> <td>0.16</td> <td>0.14</td> <td>0.12</td> <td></td> </tr> </table> <p>When capacitance is over 1000µF, tanδ shall be added 0.02 to the listed value with increase of every 1000µF.</p>	Rated Voltage (V)	6.3	10	16	25	35	(20°C, 120Hz)	tanδ	0.22	0.19	0.16	0.14	0.12								
Rated Voltage (V)	6.3	10	16	25	35	(20°C, 120Hz)																
tanδ	0.22	0.19	0.16	0.14	0.12																	
Endurance	<p>After life test with rated ripple current at conditions stated in the table below at 105°C, the capacitors shall meet the following requirements.</p> <table border="1"> <tr> <td>Capacitance Change</td> <td>Within ±25% of the initial value. (6.3v,10v : ±30%)</td> <td>Case Size</td> <td>Life Time (hrs)</td> </tr> <tr> <td>Dissipation Factor</td> <td>Not more than 200% of the specified value.</td> <td>φD ≤ 6.3</td> <td>3000</td> </tr> <tr> <td>Leakage Current</td> <td>Not more than the specified value.</td> <td>φD = 8</td> <td>4000</td> </tr> <tr> <td></td> <td></td> <td>φD = 10</td> <td>5000</td> </tr> <tr> <td></td> <td></td> <td>φD ≥ 12.5</td> <td>6000</td> </tr> </table>	Capacitance Change	Within ±25% of the initial value. (6.3v,10v : ±30%)	Case Size	Life Time (hrs)	Dissipation Factor	Not more than 200% of the specified value.	φD ≤ 6.3	3000	Leakage Current	Not more than the specified value.	φD = 8	4000			φD = 10	5000			φD ≥ 12.5	6000	
Capacitance Change	Within ±25% of the initial value. (6.3v,10v : ±30%)	Case Size	Life Time (hrs)																			
Dissipation Factor	Not more than 200% of the specified value.	φD ≤ 6.3	3000																			
Leakage Current	Not more than the specified value.	φD = 8	4000																			
		φD = 10	5000																			
		φD ≥ 12.5	6000																			
Low Temperature Stability Impedance Ratio(MAX)	<table border="1"> <tr> <td>Rated Voltage (V)</td> <td>6.3</td> <td>10</td> <td>16</td> <td>25</td> <td>35</td> <td>(120Hz)</td> </tr> <tr> <td>Z(-25°C)/Z(20°C)</td> <td>2</td> <td>2</td> <td>2</td> <td>2</td> <td>2</td> <td></td> </tr> <tr> <td>Z(-40°C)/Z(20°C)</td> <td>3</td> <td>3</td> <td>3</td> <td>3</td> <td>3</td> <td></td> </tr> </table>	Rated Voltage (V)	6.3	10	16	25	35	(120Hz)	Z(-25°C)/Z(20°C)	2	2	2	2	2		Z(-40°C)/Z(20°C)	3	3	3	3	3	
Rated Voltage (V)	6.3	10	16	25	35	(120Hz)																
Z(-25°C)/Z(20°C)	2	2	2	2	2																	
Z(-40°C)/Z(20°C)	3	3	3	3	3																	

◆MULTIPLIER FOR RIPPLE CURRENT

Frequency (Hz)		120	1k	10k	100k ≤
Coefficient	56~270µF	0.50	0.73	0.92	1.00
	330~680µF	0.55	0.77	0.94	1.00
	820~1800µF	0.60	0.80	0.96	1.00
	2200~12000µF	0.70	0.85	0.98	1.00

◆DIMENSIONS

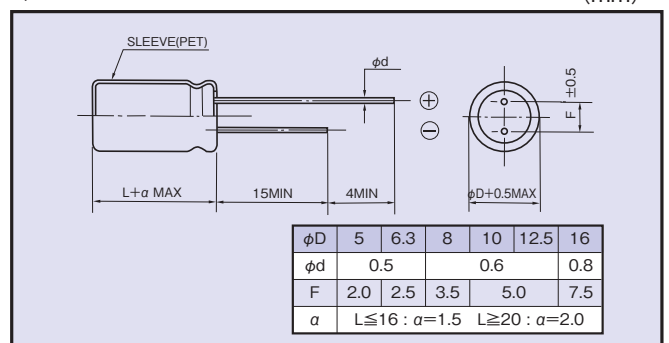

◆OPTION

	Code
PET Sleeve	EFC

◆PART NUMBER



◆STANDARD SIZE

Rated Voltage (V·DC)	Capacitance (μ F)	Size ϕ D×L(mm)	Rated ripple current (mA r.m.s./105°C, 100kHz)	Impedance (Ω MAX)	
				20°C, 100kHz	-10°C, 100kHz
6.3 (0J)	270	5×11	400	0.21	0.77
	680	6.3×11	620	0.092	0.34
	1200	8×11.5	1060	0.049	0.15
	1500	8×16	1390	0.038	0.12
	1800	10×12.5	1470	0.035	0.11
	2200	8×20	1660	0.027	0.081
	2700	10×16	1930	0.025	0.075
	3900	10×20	2130	0.018	0.054
	4700	10×25	2500	0.015	0.045
	5600	12.5×20	2690	0.016	0.041
	8200	12.5×25	3140	0.013	0.033
	8200	12.5×30	3680	0.012	0.030
	10000	16×20	3500	0.014	0.035
	10000	12.5×35	3800	0.010	0.025
12000	16×25	3880	0.011	0.028	
10 (1A)	220	5×11	400	0.21	0.77
	470	6.3×11	620	0.092	0.34
	820	8×11.5	1060	0.049	0.15
	1200	8×16	1390	0.038	0.12
	1200	10×12.5	1470	0.035	0.11
	1800	8×20	1660	0.027	0.081
	1800	10×16	1930	0.025	0.075
	2700	10×20	2130	0.018	0.054
	3300	10×25	2500	0.015	0.045
	3900	12.5×20	2690	0.016	0.041
	5600	12.5×25	3140	0.013	0.033
	6800	12.5×30	3680	0.012	0.030
	6800	16×20	3500	0.014	0.035
	8200	12.5×35	3800	0.010	0.025
8200	16×25	3880	0.011	0.028	
16 (1C)	150	5×11	400	0.21	0.77
	330	6.3×11	620	0.092	0.34
	560	8×11.5	1060	0.049	0.15
	820	8×16	1390	0.038	0.12
	820	10×12.5	1470	0.035	0.11
	1200	8×20	1660	0.027	0.081
	1200	10×16	1930	0.025	0.075
	1800	10×20	2130	0.018	0.054
	2200	10×25	2500	0.015	0.045
	2700	12.5×20	2690	0.016	0.041
	3900	12.5×25	3140	0.013	0.033
	3900	12.5×30	3680	0.012	0.030
	4700	16×20	3500	0.014	0.035
	5600	12.5×35	3800	0.010	0.025
5600	16×25	3880	0.011	0.028	

Rated Voltage (V·DC)	Capacitance (μ F)	Size ϕ D×L(mm)	Rated ripple current (mA r.m.s./105°C, 100kHz)	Impedance (Ω MAX)	
				20°C, 100kHz	-10°C, 100kHz
25 (1E)	82	5×11	400	0.21	0.77
	180	6.3×11	620	0.092	0.34
	330	8×11.5	1060	0.049	0.15
	470	8×16	1390	0.038	0.12
	560	10×12.5	1470	0.035	0.11
	680	8×20	1660	0.027	0.081
	820	10×16	1930	0.025	0.075
	1200	10×20	2130	0.018	0.054
	1500	10×25	2500	0.015	0.045
	1800	12.5×20	2690	0.016	0.041
	2200	12.5×25	3140	0.013	0.033
	2700	12.5×30	3680	0.012	0.030
	2700	16×20	3500	0.014	0.035
	3300	12.5×35	3800	0.010	0.025
3900	16×25	3880	0.011	0.028	
35 (1V)	56	5×11	400	0.21	0.77
	120	6.3×11	620	0.092	0.34
	220	8×11.5	1060	0.049	0.15
	270	8×16	1390	0.038	0.12
	330	10×12.5	1470	0.035	0.11
	390	8×20	1660	0.027	0.081
	470	10×16	1930	0.025	0.075
	680	10×20	2130	0.018	0.054
	820	10×25	2500	0.015	0.045
	1000	12.5×20	2690	0.016	0.041
	1500	12.5×25	3140	0.013	0.033
	1500	12.5×30	3680	0.012	0.030
	1800	16×20	3500	0.014	0.035
	2200	12.5×35	3800	0.010	0.025
2200	16×25	3880	0.011	0.028	