

## M21451/2/3 6.5 Gbps Backplane Signal Conditioners

### Product Overview

Mindspeed's family of 6.5 Gbps backplane signal conditioners feature small form factor, low power devices that enable data transmission over long backplanes at speeds up to 6.5 Gbps. Mindspeed's Amplif-Eye™ signal conditioning technology enables transmission of 6.5 Gbps data to distances up to one meter while also traversing two backplane connectors. These products are specifically designed to operate in environments that suffer from both loss and reflection. Each device channel features an independent equalizer and driver with programmable output swing and de-emphasis to maximize power efficiency. Virtually any digital protocol can be transmitted through the devices at speeds from 50 Mbps to 6.5 Gbps. The list of supported protocols includes: PCI Express, SATA, SAS, Infiniband, 2 x XAUI and Fibre Channel. Mindspeed's backplane signal conditioners are designed to recognize and transparently relay out-of-band (OOB) signals for SATA/SAS and PCI Express. All devices include fully non-blocking switch matrices that allow for simple switching as well as multi-cast functionality. Matrices can also be configured as failover switches. All devices operate from -40° to +85°C. Devices can either be configured via a 2 wire interface, EPROM or via hardware (4 and 12 channel only).

Features	Benefits
➤ Fully non-blocking switch matrices	Ultimate flexibility for switching and copying signals
➤ SMPTE 424M, 344M, 292M, and 259M compatible, DVB-ASI	Robust video compatibility
➤ 24 dB equalization and 6 dB of de-emphasis available	Maximizes transmission length
➤ Low 120 mW per channel power usage	Minimizes cost to operate and cool
➤ Small QFN packages	Provides space efficiency and reliability
➤ Out of band signaling support	Allows for seamless integration into PCIe, SATA and SAS
➤ Protocol agnostic	One device supports multiple applications
➤ 1.2 Volt core / optional 1.2, 1.8 or 2.5 Volt IO	Flexibility to use right power performance
➤ Extended temperature range (-40° to 85° C)	Provides additional margin for most applications
➤ Data rate independent	Operates to 6.5 Gbps, no reference clock required

### Product Selection Chart

	M21451	M21452	M21453
<b>Switch Matrix</b>	4x4	8x8	12x12
<b>Power (mW)</b>	550	900	1350
<b>Package (mm)</b>	6x6	10x10	12x12
<b>EQ Control</b>	Adaptive	Program	Program

### Mindspeed Signal Integrity

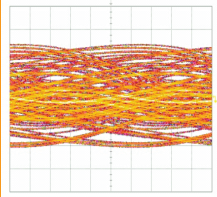
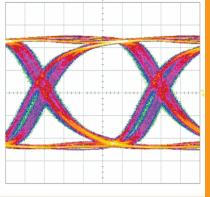



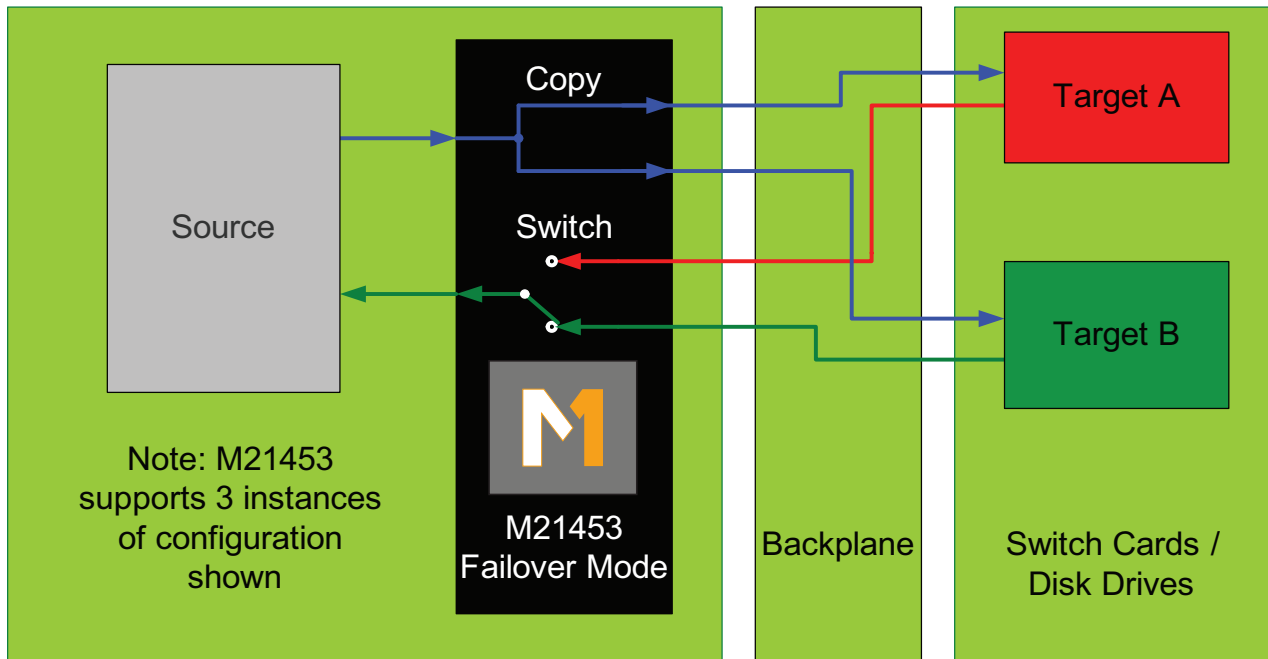

M21451/2/3 Application Diagram: Failover / Redundancy Switch

### Product Features

- Protocol agnostic
- Supports SMPTE 424M, 344M, 292M, and 259M, DVB-ASI
- Supports rates from 50 Mbps to 6.5 Gbps
- Transparently relays OOB/EBI
- Extended temperature range -40° to +85°C
- Boundary scan
- 1.2V core
- 1.2V or 1.8V IO option

### Applications

- Backplane equalizer / driver
- SDI video and DVB-ASI equipment
- SATA / SAS redundancy switch
- Blade server board to board interconnect
- Infiniband reach extension
- PCI Express failover switch

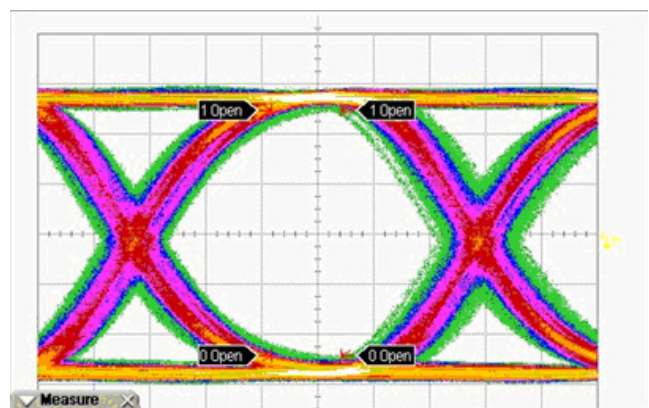
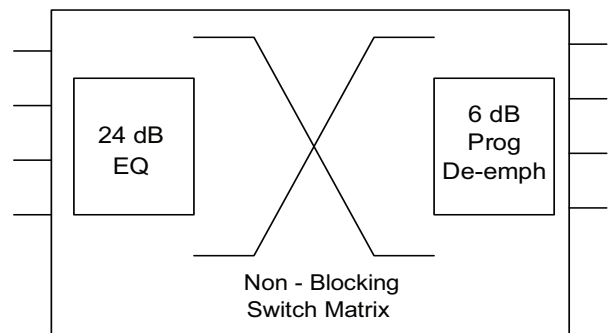

6.5 Gbps Equalized After 36" Trace

For more product information, please visit [www.mindspeed.com](http://www.mindspeed.com).

[www.mindspeed.com/salesoffices](http://www.mindspeed.com/salesoffices)

General Information: (949) 579-3000  
 Headquarters – Newport Beach  
 4000 MacArthur Blvd., East Tower  
 Newport Beach, CA 92660-3007  
 M21451-BRF-001-A.pdf

© 2008 Mindspeed Technologies, Inc. All rights reserved. Mindspeed and the Mindspeed logo are trademarks of Mindspeed Technologies, Inc. All other trademarks are the property of their respective owners. Although Mindspeed Technologies, Inc. strives for accuracy in all its publications, this material may contain errors or omissions and is subject to change without notice. This material is provided as is and without any express or implied warranties, including merchantability, fitness for a particular purpose and non-infringement. Mindspeed Technologies, Inc. shall not be liable for any special, indirect, incidental or consequential damages as a result of its use.

### Ordering Info:

- M21451G-13
- M21452G-13
- M21453G-13