

1.5A Buck Includes >90V Integrated Automotive Load Dump Protection

Ideal for Automotive and Industrial Applications

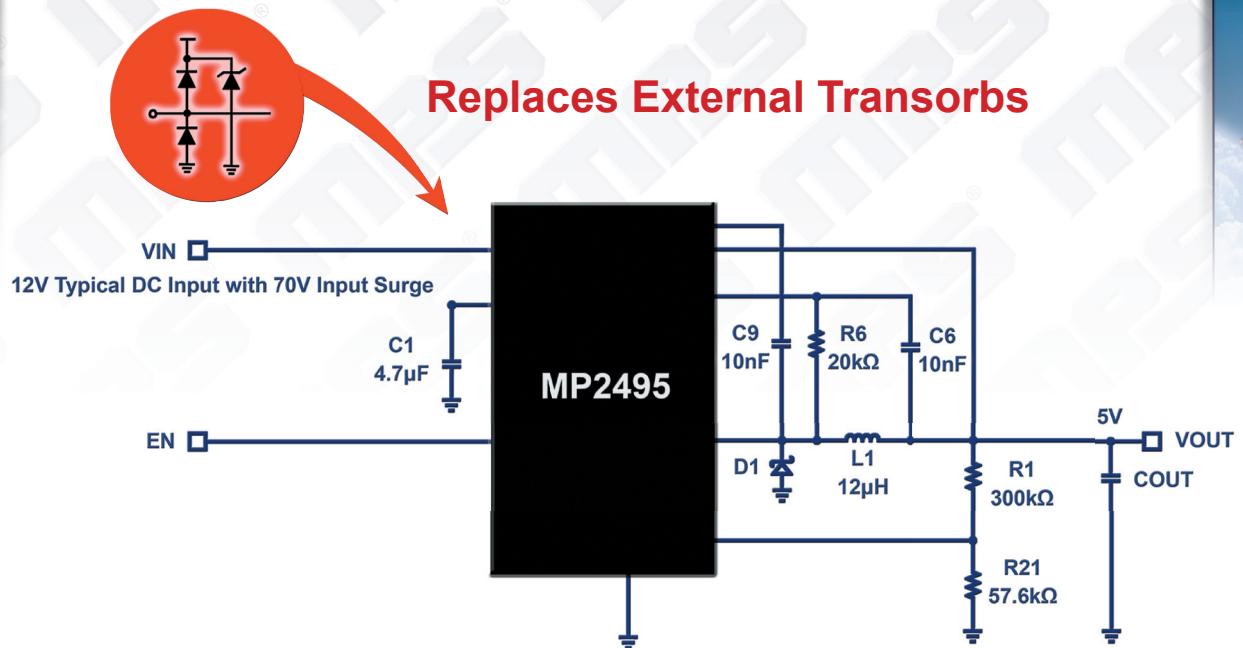

MP2495 Features

- Withstands >90V Automotive Load Dump
- Programmable up to 1.5A Output Current
- Programmable Output Current Limit Without Power Loss
- 95% Efficiency @ 500mA (Vo=5V)
- Fixed 700KHz Frequency
- Thermal Shutdown
- Cycle-by-Cycle Over Current Protection
- Available in a 16-Pin SOIC Package

Efficiency vs. Load Current

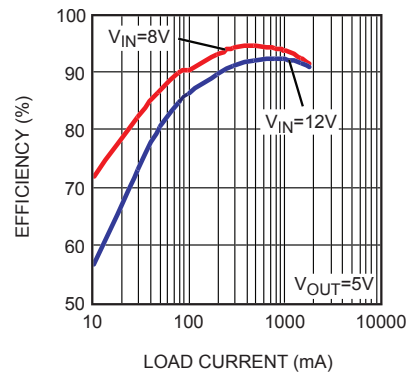

DC/DC

MPS

Monolithic Power Systems®
The Future of Analog IC Technology®
www.monolithicpower.com

© 2009 Monolithic Power Systems, Inc. All Rights Reserved.

CODICO
the component distributing company

Zwingenstrasse 6-8 | 2380 Perchtoldsdorf | Austria
Tel: +43 1 86 305 - 0 | Fax: +43 1 86 305 - 5000
E-mail: office@codico.com | www.codico.com

