



ZLE60300

Evaluation Kit for Pluggable Parallel Fiber Modules Data Sheet

April 2007

Description

The ZLE60300 evaluation kit is designed for high-speed evaluation of Zarlink's ZL603xx family of pluggable optical parallel fiber 4x transceiver modules. The kit consists of two evaluation boards and one transceiver optical test fiber ribbon cable. The evaluation board is fitted with a MegArray[®] electrical socket where the optical module can be plugged in. SMA connectors are provided for the differential, AC-coupled, high-speed CML I/O interface.

Electrical Connections

Each evaluation board is equipped with a switch to enable/disable certain functions within the module, see subsequent sections.

LEDs on the evaluation boards indicate the status of different signal outputs.

To ensure best performance, it is strongly recommended to terminate unused data input/output connectors with 50 Ω single-ended SMA-terminations.

Ordering Information

- ZLE60300 including
- Transceiver evaluation board with MegArray[®] socket
- Optical test fiber ribbon cable, 50/125 μm with MPO/MTP[®] connectors

Note: ZL603xx family pluggable optical transceiver should be ordered separately.

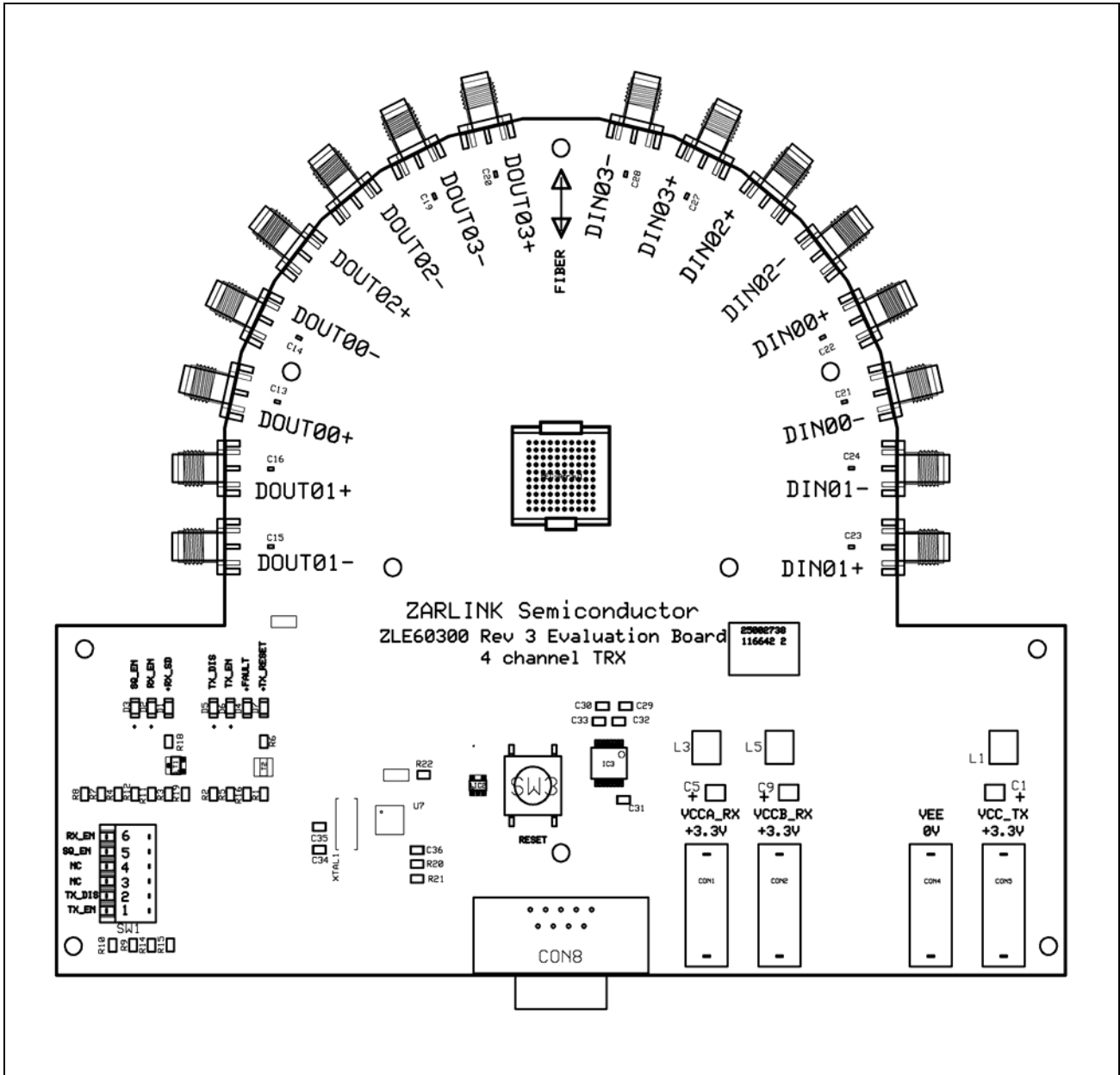

Figure 1 - Transceiver Evaluation Board

Separate power supplies for the receiver and the transmitter should be used for best performance. VCCA_Rx (CON1) and VCCB_Rx (CON2) on the receiver supply could be tied together.

| | | | |
|------|----------|--|---------------|
| 1 | TxEN | Tx enable Normal operation when toggled ON | Toggle switch |
| 2 | TxDIS | Transmitter disable Normal operation when toggled OFF | Toggle switch |
| 3 | NC | No connection | Toggle switch |
| 4 | NC | No connection | Toggle switch |
| 5 | SQ_EN | Squelch enable Squelch enabled when toggled ON | Toggle switch |
| 6 | RxEN | Receiver enable Normal operation when toggled ON | Toggle switch |
| | SQ_EN | Squelch enable Active when squelch enabled | LED indicator |
| | RX_EN | Receiver enable Active when receiver enabled | LED indicator |
| | RxSD | Receiver signal detect Active when valid optical input on all channels | LED indicator |
| | TX_DIS | Transmitter disable Active when transmitter disabled | LED indicator |
| | TX_EN | Transmitter enable Active when transmitter enabled | LED indicator |
| | FAULT | Transmitter fault Active when laser fault detected on at least one channel | LED indicator |
| | TX_RESET | Transmitter reset Active when transmitter under reset | LED indicator |
| CON8 | D-Sub | Used for connecting RS232 cable for communication (SPI) | Contact |
| SW3 | RESET | Transmitter reset Press to clear fault. Reloads registers into the VCSEL driver. Ready to operate when the reload is done. | Push button |

Table 1 - Transceiver Control and Status Functions



**For more information about all Zarlink products
visit our Web Site at
www.zarlink.com**

Information relating to products and services furnished herein by Zarlink Semiconductor Inc. or its subsidiaries (collectively "Zarlink") is believed to be reliable. However, Zarlink assumes no liability for errors that may appear in this publication, or for liability otherwise arising from the application or use of any such information, product or service or for any infringement of patents or other intellectual property rights owned by third parties which may result from such application or use. Neither the supply of such information or purchase of product or service conveys any license, either express or implied, under patents or other intellectual property rights owned by Zarlink or licensed from third parties by Zarlink, whatsoever. Purchasers of products are also hereby notified that the use of product in certain ways or in combination with Zarlink, or non-Zarlink furnished goods or services may infringe patents or other intellectual property rights owned by Zarlink.

This publication is issued to provide information only and (unless agreed by Zarlink in writing) may not be used, applied or reproduced for any purpose nor form part of any order or contract nor to be regarded as a representation relating to the products or services concerned. The products, their specifications, services and other information appearing in this publication are subject to change by Zarlink without notice. No warranty or guarantee express or implied is made regarding the capability, performance or suitability of any product or service. Information concerning possible methods of use is provided as a guide only and does not constitute any guarantee that such methods of use will be satisfactory in a specific piece of equipment. It is the user's responsibility to fully determine the performance and suitability of any equipment using such information and to ensure that any publication or data used is up to date and has not been superseded. Manufacturing does not necessarily include testing of all functions or parameters. These products are not suitable for use in any medical products whose failure to perform may result in significant injury or death to the user. All products and materials are sold and services provided subject to Zarlink's conditions of sale which are available on request.

Purchase of Zarlink's I²C components conveys a licence under the Philips I²C Patent rights to use these components in and I²C System, provided that the system conforms to the I²C Standard Specification as defined by Philips.

Zarlink, ZL and the Zarlink Semiconductor logo are trademarks of Zarlink Semiconductor Inc.

Copyright Zarlink Semiconductor Inc. All Rights Reserved.

TECHNICAL DOCUMENTATION - NOT FOR RESALE

Your contact: www.codico.com mailto: office@codico.com phone: +43/1/86305-0 fax: +43/1/86305-98
