

SPECIFICATIONS FOR LCD MODULE

CUSTOMER	
CUSTOMER PART NO.	
AMPIRE PART NO.	AT-320240Q2 (Built-in Controller)
APPROVED BY	
DATE	

APPROVED BY	CHECKED BY	ORGANIZED BY

RECORD OF REVISION

Revision Date	Contents
2001/4/12	New Release
2001/5/16	Revise the Power circuit (Page 6)

1 FEATURES

- (1) Display format : 320 × 240 dot-matrix, 1/240 duty.
- (2) Construction : Paper White type FSTN LCD, TAB type LCD driver and PCB.
- (3) Option : Touch Panel, Touch Panel controller.
- (4) Controller : SED1335F0B.
- (5) **New Driving Method** CMOS LCD Driver for Low Power Consumption Driving.
- (6) 5V or 3.3V single power input. Built-in specific power supplies circuit for LCD driving. **Ultra Low Power Consumption.**
- (7) Normal / Extended temperature type.
- (8) Portrait(Default) or Landscape Display Type Selectable by Jumper Setting.
- (9) 80 or 68 Family MPU Selectable by Jumper Setting

2 MECHANICAL DATA

Parameter	Stand Value	Unit
Dot size	0.225(W) × 0.225(H)	mm
Dot pitch	0.24(W) × 0.24(H)	mm
Viewing area	81.8 (W) × 62.0 (H)	mm
Module size (w/ LED backlight)	95.2(W) × 73.0(H) × 6.5 max (T)	mm
Module size (w/ Touch panel)	95.2(W) × 73.0(H) × 8.0 max (T)	mm

3 ABSOLUTE MAXIMUM RATINGS

Parameter		Symbol	Min	Max	Unit
Logic Circuit Supply Voltage		VDD-VSS	-0.3	7.0	V
LCD Driving Voltage		--	-0.3	26.0	V
Input Voltage		VI	-0.3	VDD+0.3	V
Normal tmp. type	Operating Temp.	TOP	0	50	°C
	Storage Temp.	TSTG	-20	70	°C
Extended temp. type	Operating Temp.	TOP	-20	70	°C
	Storage Temp.	TSTG	-30	80	°C

4 ELECTRO-OPTICAL CHARACTERISTICS

Parameter	Symbol	Condition	Min	Typ	Max	Unit	Note
----- Electronic Characteristics -----							
Logic Circuit Supply Voltage	VDD-VSS	--	2.6	3.3	5.5	V	
LCD Driving Voltage	--	-20 °C	25.3	25.8	26.3	V	0 ~ 50 °C for Normal Temp. type -20 ~ 70 °C for Extended Temp. type
		0 °C	23.8	24.2	24.6		
		25 °C	22.5	22.9	23.3		
		50 °C	21.0	21.4	21.8		
		70 °C	20.1	20.5	20.9		
Input Voltage	VIH	--	0.7 VDD	--	VDD	V	
	VIL	--	VSS	--	0.3 VDD	V	
Logic Supply Current	ICC	VCC = 3.3V	--	20	--	mA	
----- Optical Characteristics -----							
Contrast	CR	FSTN type		7			Note 1
Rise Time	tr	25°C	--	305	450	ms	Note 2
Fall Time	tf	25°C	--	120	180	ms	
Viewing Angle Range	θ f	25°C & CR≥2	--	40	--	Deg.	Note 3
	θ b		--	35	--		
	θ l		--	35	--		
	θ r		--	35	--		
Frame Frequency	fF	25°C	--	64	--	Hz	
----- White LED Back-light Characteristics -----							
Parameter	Symbol	Condition	Min	Typ	Max	Unit	Note
Forward Voltage	VF	--	--	3.2	3.8	V	Supply Voltage between A&K
Forward Current	IF	VF=3.2V	--	80	--	mA	
Bare LED Luminous intensity		VF=3.2V	--	60	--	cd/m ²	
LCM Luminous intensity		VF=3.2V	--	8	--	cd/m ²	

* LED Dice number = 4

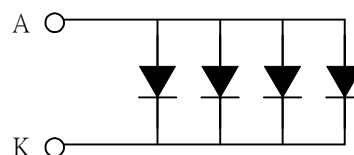

(NOTE 1) Contrast ratio :

$$CR = (\text{Brightness in OFF state}) / (\text{Brightness in ON state})$$

(NOTE 2) Response time :

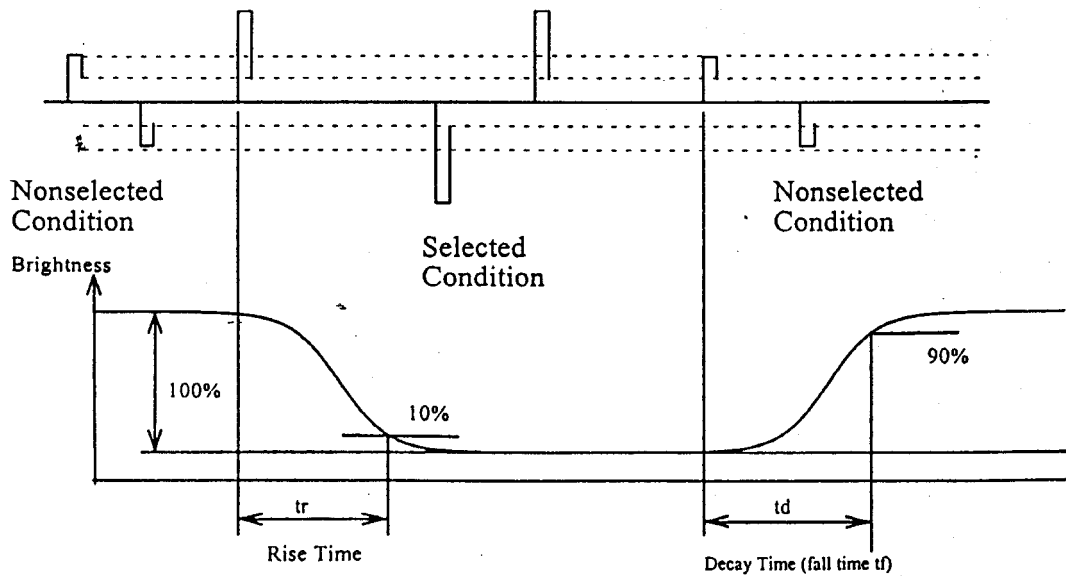

(NOTE 3) Viewing angle

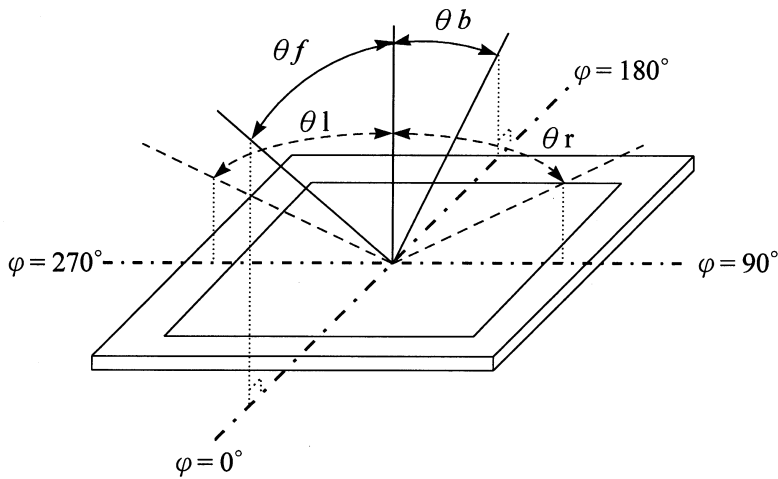

Touch Panel Electrical Specification

Parameter	Specification	Condition
ON Resistance	400 Ω ~ 800 Ω	X Axis
	260 Ω ~ 600 Ω	Y Axis
Insulating Resistance	More than 10M Ω	DC 25 V
Chattering	Less Than 15 ms	100K Ω Pull-Up

5 BLOCK DIAGRAM

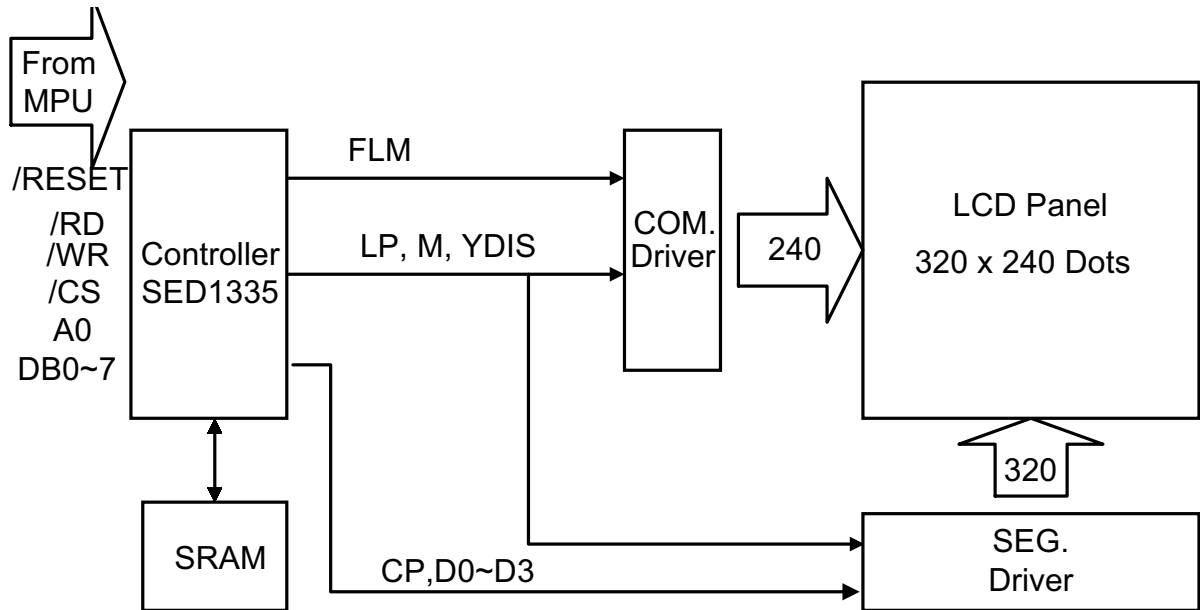

* Please use the YDIS pin and the inner command of the SED1335 to control Display On/Off.

Power Supply Example

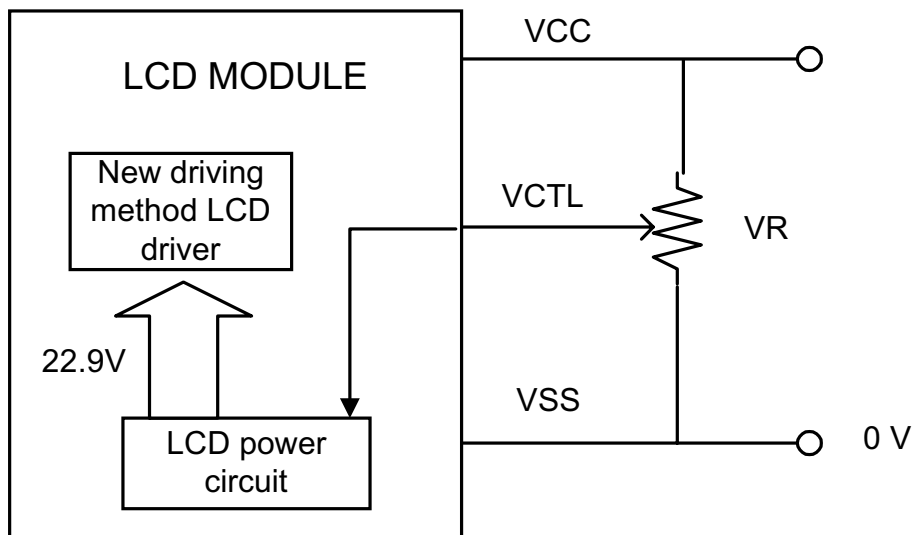

6 INTERFACE DEFINITION

PIN NO.	SIGNAL	LEVEL	FUNCTION
1	/RESET	H/L	Reset Signal
2	/RD	H/L	80 Series: Read Signal 68 Series: Enable Signal(E)
3	/WR	H/L	80 Series: Write Signal 68 Series: R/W Signal
4	/CS	H/L	Chip Select Signal
5	A0	H/L	Data Type Selection
6 ~ 13	DB0~DB7	H/L	Data Input(8 bits)
14	VCC	-	Power Supply for Logic(+3.0V)
15	VSS	-	Power Supply(Ground : 0V)
16	VCTL	-	Contrast Adjustment Input
17	NC	-	No Connection
18*	SK / X1	-	Serial Clock Touch Panel Left Signal in X Axis
19*	DO / X2	-	Data Output Touch Panel Right Signal in X Axis
20*	DI / Y1	-	Data In Touch Panel Upper Signal in Y Axis
21*	CS / Y2	-	Chip Select Touch Panel Lower Signal in X Axis
22*	INT	-	Interrupt
23	A	-	LED Anode
24	K		LED Cathode

* 18~22 : SK, DO, DI, CS, INT for Touch Panel controller MK715

/ X1, X2, Y1, Y2 for Touch Panel (without MK715)

7 TIMING CHARACTERISTICS

7.1 8080 Family Interface Timing

Parameter	Condition	Symbol	Min	Max	Unit	Remark
Address Hold Time	CL=100 pF VDD=2.7~4.5	tAH8	10		ns	A0,/CS
Address Setup Time		tAW8	0		ns	
System Cycle Time		tCYC	Note		ns	/WR,/RD
Strobe Pulse Width		tOC	150		ns	DB0~DB7
Data Setup Time		tDS8	120		ns	
Data Hold Time		tDH8	5		ns	
/RD Access Time		tACC8	-	80	ns	
Output Disable Time		tOH8	10	55	ns	

Note: For memory control and system control commands:

$$t_{CYC8} = 2t_C + t_{OC} + t_{CEA} + 75 > t_{ACV} + 245$$

For all other commands:

$$t_{CYC8} = 4t_C + t_{OC} + 30$$

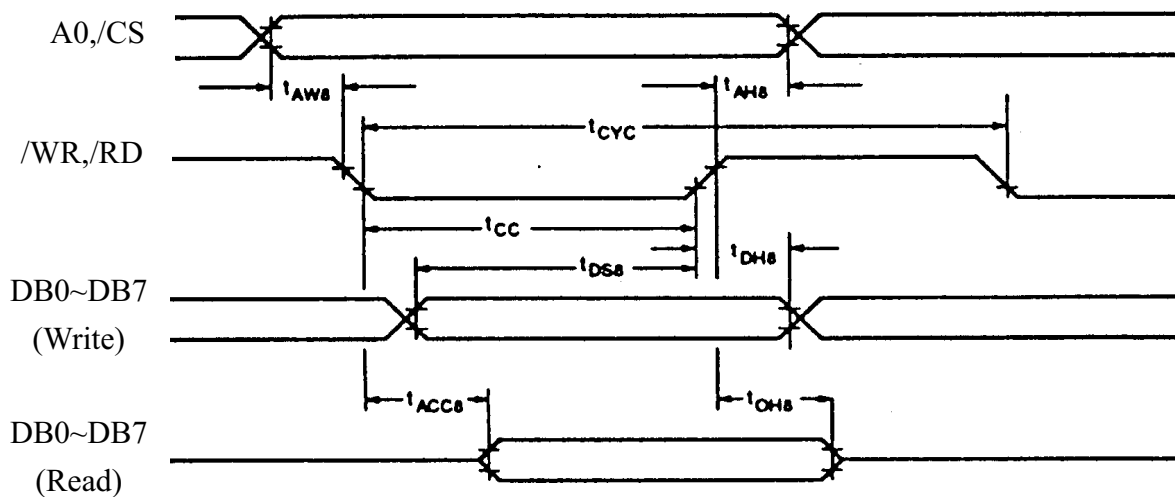

7.2 6800 Family Interface Timing

Parameter	Condition	Symbol	Min	Max	Unit	Remark
System Cycle Time	CL=100 pF VDD=2.7~4.5	tCYC6	Note		ns	A0,/CS, R/W
Address Setup Time		tAW6	10		ns	
Address Hold Time		tAH6	0		ns	
Data Setup Time		tDS6	120		ns	DB0~DB7
Data Hold Time		tDH6	0		ns	
Output Disable Time		tOH6	10	75	ns	
Access Time		tACC6	-	130	ns	
Enable Pulsewidth		tEW	150	-	ns	E

Note: For memory control and system control commands:

$$t_{CYC6} = 2t_C + t_{EW} + t_{CEA} + 75 > t_{ACV} + 245$$

For all other commands:

$$t_{CYC6} = 4t_C + t_{EW} + 30$$

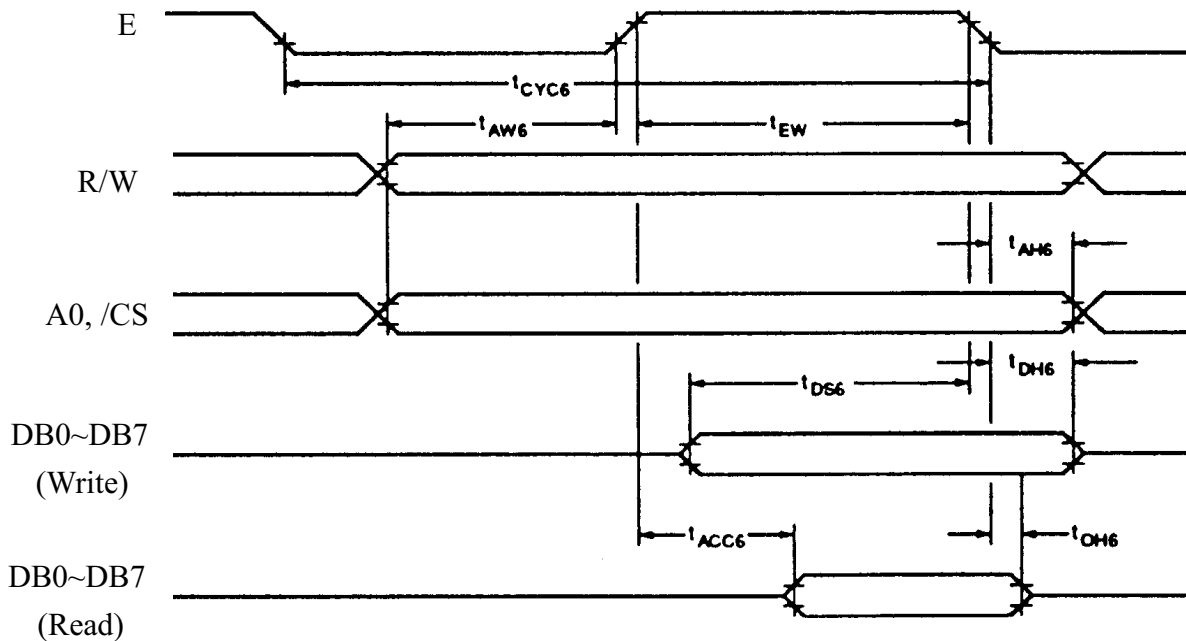

AC Electrical Characteristics

8 INSTRUCTION SET

Class	Command	Code											Hex	Command Description	Command read parameters	
		/RD	/WR	A0	D7	D6	D5	D4	D3	D2	D1	D0			Number of bytes	Section
System Control	SYSTEM SET	1	0	1	0	1	0	0	0	0	0	0	40	Initialized Device and display	8	8.2.1
	SLEEP IN	1	0	1	0	1	0	1	0	0	1	1	53	Enter Standby mode	0	8.2.2
Display Control	DISP ON/OFF	1	0	1	0	1	0	1	1	0	0	D	58, 59	Enable and disable display and display flashing	1	8.3.1
	SCROLL	1	0	1	0	1	0	0	0	1	0	0	44	set Display start address and display regions	10	8.3.2
	CSRFORM	1	0	1	0	1	0	1	1	1	0	1	5D	Set cursor byte	2	8.3.3
	CGRAM ADDR.	1	0	1	0	1	0	1	1	1	0	0	5C	Set start address of character generator RAM	2	8.3.6
	CSRDIR	1	0	1	0	1	0	0	1	1	CD 1	CD 0	4C to 4F	Set direction of cursor movement	0	8.3.4
	HDOT SCR	1	0	1	0	1	0	1	1		1	0	5A	set horizontal scroll position	1	8.3.7
	OVLAY	1	0	1	0	1	0	1	1	0	1	1	5B	set display overlay format	1	8.3.5
Drawing Control	CSRW	1	0	1	0	1	0	0	0	1	1	0	46	set cursor address	2	8.4.1
	CSRR	1	0	1	0	1	0	0	0	1	1	1	47	read cursor address	2	8.4.2
Memory Control	MWRITE	1	0	1	0	1	0	0	0	0	1	0	42	write to display memory	-	8.5.1
	MREAD	1	0	1	0	1	0	0	0	0	1	1	43	read from display memory	-	8.5.2

Note:

- In general, the internal registers of the SED1335F are modified as each command parameter is input. However, the microprocessor does not have to set all the parameters of a command and may send a new command before all parameters have been input. The internal registers for the parameters that have been input will have been changed but the remaining parameter registers are unchanged.
 - 2 bytes parameters(where two bytes are treated as 1 data item) are handled as following:
 - CSRW, CSRR: Each byte is processed individually. The microprocessor may read or write just the low byte of the cursor address.
 - SYSTEM SET, SCROLL, CGRAM ADR. : Both parameter bytes are processed together. If the command is changed after half of the parameter has been input, the single byte is ignored.
- APL and APH are 2-byte parameters, but are treated as two 1-byte parameters.
- Please refer to SED1335F LCD Controller Data Book for detail.

9 INNER DATA FORMAT

	COM1								COM240
#1	D3	D3	D3						D3
#2	D2	D2	D2						D2
	D1	D1	D1						D1
	D0	D0	D0						D0
	D3								D3
	D2	D2							D2
	D1	D1							D1
#320	D0	D0							D0

Portrait Display Type (Top View)

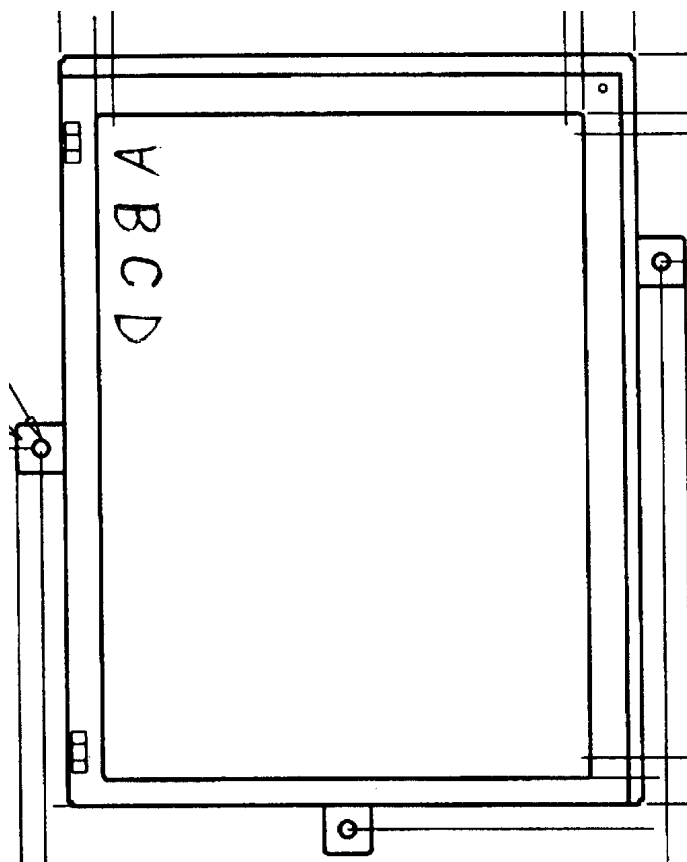

	SEG1										SEG320				
#1	D3	D2	D1	D0	D3	D2			-			D3	D2	D1	D0
#2	D3	D2	D1	D0	D3	D2						D3	D2	D1	D0
#240	D3	D2	D1	D0	D3	D2						D3	D2	D1	D0

Landscape Display Type(Top View)

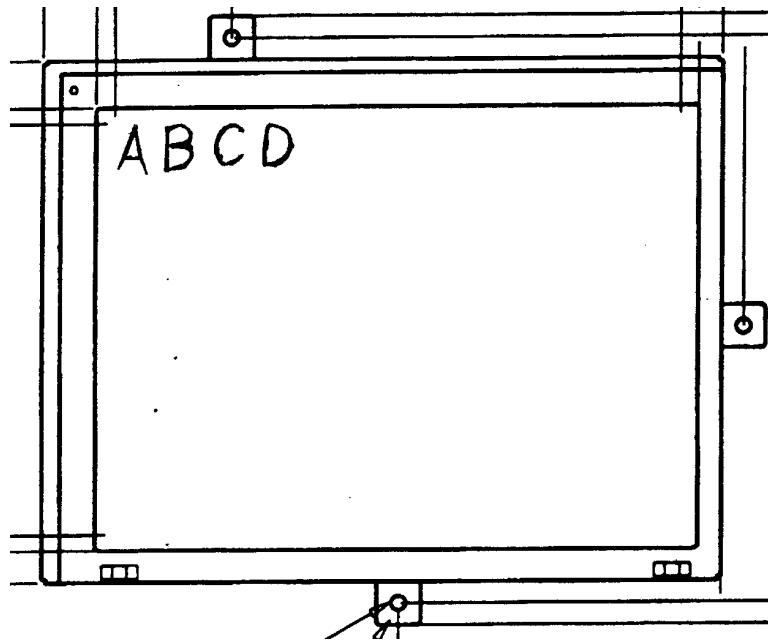

* Regardless Portrait or Landscape type, both are 1/240 duty. The only difference is the opposite scan direction on Common driver. The character mode of SED1335 could only be used on Landscape type. The character will be Mirrored on Portrait type.

10 JUMPER SETTING

Item	Option	Jumper Setting	Remark
Display Type	Portrait (default)	Pin 1,2 short on JP1&JP2	
	Landscape	Pin 2,3 short on JP1&JP2	
MPU	80 family (default)	Pin 1,2 short on JP4	
	68 family	Pin 2,3 short on JP4	

11 QUALITY AND RELIABILITY

11.1 TEST CONDITIONS

Tests should be conducted under the following conditions :

Ambient temperature : $25 \pm 5^{\circ}\text{C}$

Humidity : $60 \pm 25\% \text{ RH}$.

11.2 SAMPLING PLAN

Sampling method shall be in accordance with MIL-STD-105E , level II, normal single sampling plan .

11.3 ACCEPTABLE QUALITY LEVEL

A major defect is defined as one that could cause failure to or materially reduce the usability of the unit for its intended purpose. A minor defect is one that does not materially reduce the usability of the unit for its intended purpose or is an infringement from established standards and has no significant bearing on its effective use or operation.

11.4 APPEARANCE

An appearance test should be conducted by human sight at approximately 30 cm distance from the LCD module under fluorescent light. The inspection area of LCD panel shall be within the range of following limits.

11.5 INSPECTION QUALITY CRITERIA

Item	Description of defects			Class of Defects	Acceptable level (%)
Function	Short circuit or Pattern cut			Major	0.65
Dimension	Deviation from drawings			Major	1.5
Black spots	Ave . dia . D	area A	area B	Minor	2.5
	D≤0.2	Disregard			
	0.2<D≤0.3	3	4		
	0.3<D≤0.4	2	3		
	0.4<D	0	1		
Black lines	Width W, Length L	A	B	Minor	2.5
	W≤0.03	disregard			
	0.03<W≤0.05	3	4		
	0.05<W≤0.07 , L≤3.0	1	1		
	See line criteria				
Bubbles in polarizer	Average diameter D 0.2 < D < 0.5 mm for N = 4 , D > 0.5 for N = 1			Minor	2.5
Color uniformity	Rainbow color or newton ring.			Minor	2.5
Glass Scratches	Obvious visible damage.			Minor	2.5
Contrast ratio	See note 1			Minor	2.5
Response time	See note 2			Minor	2.5
Viewing angle	See note 3			Minor	2.5

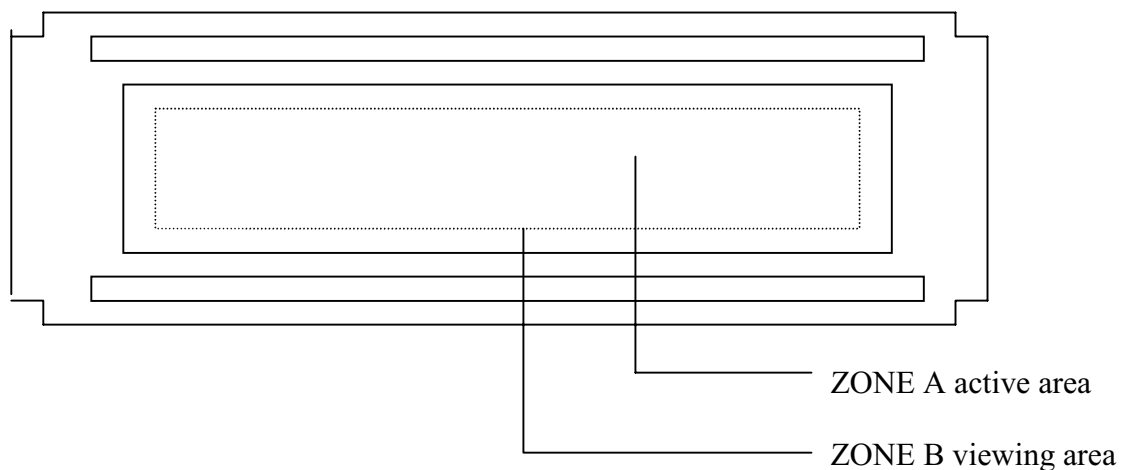

11.6 RELIABILITY

Test Item	Test Conditions		Note
	Normal Temp. type	Extended Temp. type	
High Temperature Operation	50±3°C , t=96 hrs	70±3°C , t=96 hrs	
Low Temperature Operation	0±3°C , t=96 hrs	-20±3°C , t=96 hrs	
High Temperature Storage	70±3°C , t=96 hrs	80±3°C , t=96 hrs	1,2
Low Temperature Storage	-20±3°C , t=96 hrs	-30±3°C , t=96 hrs	1,2
Thermal Shock Test	-20°C ~ 25°C ~ 70°C 30 m in. 5 min. 30 min. (1 cycle) Total 5 cycle	-30°C ~ 25°C ~ 80°C 30 min. 5 min. 30 min. (1 cycle) Total 5 cycle	1,2
Humidity Test	40 °C, Humidity 90%, 96 hrs		1,2
Vibration Test (Packing)	Sweep frequency : 10 ~ 55 ~ 10 Hz/1min Amplitude : 0.75mm Test direction : X.Y.Z/3 axis Duration : 30min/each axis		2

Note 1 : Condensation of water is not permitted on the module.

Note 2 : The module should be inspected after 1 hour storage in normal conditions
(15-35°C , 45-65%RH).

Definitions of life end point :

- Current drain should be smaller than the specific value.
- Function of the module should be maintained.
- Appearance and display quality should not have degraded noticeably.
- Contrast ratio should be greater than 50% of the initial value.

12 HANDLING PRECAUTIONS

- (1) A LCD module is a fragile item and should not be subjected to strong mechanical shocks.
- (2) Avoid applying pressure to the module surface. This will distort the glass and cause a change in color.
- (3) Under no circumstances should the position of the bezel tabs or their shape be modified.
- (4) Do not modify the display PCB in either shape or positioning of components.
- (5) Do not modify or move location of the zebra or heat seal connectors.
- (6) The device should only be soldered to during interfacing. Modification to other areas of the board should not be carried out.
- (7) In the event of LCD breakage and resultant leakage of fluid do not inhale, ingest or make contact with the skin. If contact is made rinse immediately.
- (8) When cleaning the module use a soft damp cloth with a mild solvent, such as Isopropyl or Ethyl alcohol. The use of water, ketone or aromatic is not permitted.
- (9) Prior to initial power up input signals should not be applied.
- (10) Protect the module against static electricity and observe appropriate anti-static precautions.

13 OUTLINE DIMENSION

