

IMPULSE

ISSUE
2014:1

NEW: RELAYS FROM SANYOU & GOODSKY

QUALCOMM Atheros & WISTRON have teamed up: Internet of Things

HIROSE, FCI & CviLux: Connections that really light up LEDs!



CONTENTS



©Serg Nims - Fotolia.com

32 | NEW AT CODICO: SANYOU & GOODSKY

As the technical partner for Design-In, CODICO has reacted to the need to include electromechanical relays in the portfolio. The suppliers selected – GOODSKY & SANYOU – are focused exclusively on relays and provide a defined roadmap for products and processes as assurance of future advantages. The focus at CODICO in the first instance is on applications in industry, building technology, white goods, and the energy management sector.

IMPULSE | ACTIVE COMPONENTS

- 04** | QUALCOMM ATHEROS and WISTRON have teamed up: Internet of Things
- 06** | PLC Bundle for Internet of Things with solutions of QUALCOMM ATHEROS & I2SE
- 08** | MPQ4569: The new synchronous step-down converter of MPS
- 10** | TOREX converter news: XCL211/12, XCL101 and XC9306
- 11** | The Midget! COSEL's TUHS series, the smallest standby power supply available on the market
- 12** | We are complete! COSEL introduces 480W version of the KH series
- 13** | ARTESYN's 3 Phase Din Rail series for industrial applications
- 14** | EOS introduces supply for sensitive medical applications
- 15** | Full power unleashed – the Nevo+1200 of VOX Power
- 16** | Little Giants – SILVERTEL's new PoE range family
- 18** | New supplier at CODICO: LANTIQ – Lantiq SOCRATES™ and Gigabit Ethernet PHY
- 21** | ATMEL »SAM D« microcontrollers
- 22** | VITESSE introduces industry's first field-proven, turnkey software for carrier ethernet service delivery
- 23** | Small, black & powerful: MPS DC/DC modules
- 25** | SILVERTEL makes wireless power – simple!



IMPULSE | PASSIVE COMPONENTS

- 26** | ELYTONE: Full power ahead!
- 26** | Wireless charging – It's in fashion!
- 27** | TOKO's ultra small power inductors
- 28** | MURATA's MEMS based on 3D technology
- 30** | Capacitor news: From double-layer to aluminium polymer capacitors
- 31** | Loss of capacitance with X2 film capacitors – here's the answer!
- 32** | New in the range: Electromechanical relays from SANYOU and GOODSKY
- 35** | TT Electronics: Accuracy & stability



IMPULSE | CONNECTORS

- 36** | FCI's robust and green two-piece High Power Card Edge® board-to-board connector
- 37** | Multifunctional LED connection system from HIROSE
- 38** | HIROSE: Fully waterproof
- 39** | RFI shield cans from HARWIN: Suitable for automated assembly
- 40** | DINKLE's LED terminal blocks – ideal for industrial control!
- 41** | A real highlight among card readers: YAMAICHI's FPS009-2903-0
- 42** | CviLux and HIROSE: Connections that really light up LEDs!
- 43** | YAMAICHI Electronics' Y-Circ® P: New circular connector with push-pull locking
- 44** | RFK 2 – STOCKO's sovereign solution for Pitch 2.5 connections

IMPULSE | CODICO IN-HOUSE

- 03** | We're always keen to hear your opinions!
- 45** | CODICO at the embedded world 2014
- 46** | Get to know the CODICO team

We're always keen to hear your opinions!

Carrying out supplier evaluations is not only a standard task for every company which has introduced a quality management system and is certified to ISO 9001:2008, but is also a tried and trusted way of identifying preferred suppliers easily and meaningfully. And it makes us happy when so many of our customers let us know regularly and in detail about our performance and the services we provide for them.

Here are a few examples:

Fronius International GmbH, Austria, was able to award CODICO the status of an »A-Supplier«, RAFI GmbH & Co. KG, Germany, finds our overall performance »excellent« and Siemens AG Austria rated us »outstanding«.

One of the most important aims at CODICO is the focus on the customer. Fulfilling the expectations and requirements of our customers is an essential task, and it is one that all our staff work together to achieve, every day. But without regular feedback from our customers, we would only be able to develop our service from our own point of view.

We value all our business partner's contribution supporting us in the coming even better.

D01

▶ Petra Huynh, +43 1 86305 159
petra.huynh@codico.com



Sven Krumpel
CEO CODICO



TRIDONIC
Award

Dear Readers,

We are looking to the future – and we're full of optimism! The distributors' sector is assessing the prospects for the next twelve months as very positive. But satisfactory forecasts aren't enough for us. As a design-in company, we concentrate not only on offering parts and components at an economical price, and selling them. Service, customer focus, and innovation are the key factors for CODICO. And that's why we are reacting to what our customers need, by letting you know about the marketing of a new product group from CODICO, the electromechanical relays, which represent a valuable and logical supplement to our product portfolio. The suppliers who are selected for inclusion in this specific CODICO portfolio focus exclusively on relays, and provide top quality products and processes. We are extending our range, while at the same time remaining true to our role as prime partners when it comes to technical design-in services. And that's why we can look to the future with such optimism.

But we can also look back with satisfaction to the past, to an extremely successful embedded world 2014! The fair in Nuremberg opened its doors from 24-26 February to almost 27,000 visitors and 856 exhibitors. On our CODICO booth there was the opportunity to hold technical discussions with our staff, experience product presentations, and, of course, have some fun and excitement! Our two-level handmade racetrack, an original creation from the Vienna Museum Quarter, was a great opportunity for our visitors to see who could achieve the best lap times.

We are already looking forward to an exciting and successful 2014 together with you, and we hope you have lots of fun reading our CODICO Impulse!

D02

▶ Sven Krumpel



QUALCOMM ATHEROS and WISTRON have teamed up:

Over the next few years, an increasing number of devices will be equipped in order to automatically send and receive data via the Internet. According to official estimates, as early as 2015, more than 6 billion devices will be connected to each other via the Internet. Today, the Internet of Things (IoT) is no longer a vision but rather already a reality. Therefore it is hardly surprising that more and more manufacturers are converting their systems and devices accordingly.

With regard to Wi-Fi, the aim is to achieve increasingly smaller and compact solutions, which, at the same time, cost even less. Low-Power is also an important factor, since devices are often powered by a battery. WISTRON has responded to this demand by offering a Wi-Fi module solution based on the new IoT chip by QUALCOMM ATHEROS.



INTERNET OF THINGS

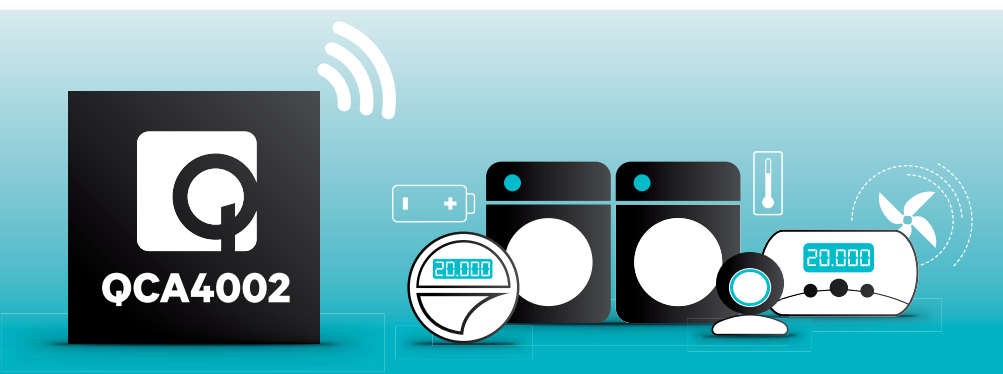

via AT commands, whereas, if a higher data throughput and increased protocol functionality are required, an SPI interface can be used as an alternative. In order to do this, the corresponding Open Source API drivers must be ported

In the last edition of Impulse, we have already extensively described the new Wi-Fi solution by QUALCOMM ATHEROS, which was optimised specifically for IoT applications with a focus on Low-Power and Low-Cost. This solution is

based on a single highly integrated chip called QCA4002. Thanks to its serial interfaces, it allows quick and easy integration into a MCU-based system environment. For simple applications, the QCA4002 can be controlled through UART

QCA4002

- > Dual-band 2.4GHz / 5GHz
- > IEEE 802.11a/b/g/n, Single Stream 1 x 1
- > Integrated PA, LNA with support for external PA and LNA
- > Green Tx Power Saving, Low Power Listen and IEEE Sleep Mode
- > Single power supply: 3.3V
- > Integrated IPv4/IPv6 networking stack
- > Full security support: SSL, WPS, WPA, WPA2, WEP
- > Integrated services: HTTP, DHCP, DNS, ICMP, IGMP
- > Easy to use UART or SPI host interface
- > 58 pin QFN 7mm x 7mm
- > Operation temperature: -40°C – 85°C

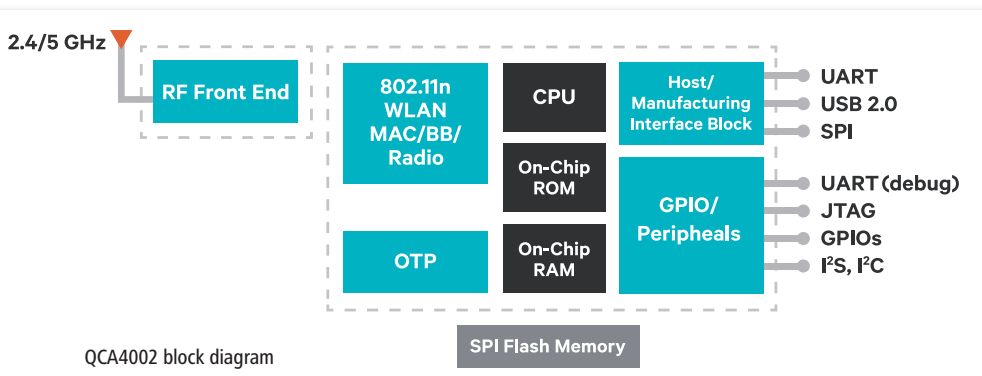

QCA4002 block diagram



to the host MCUs, which are provided as C-Code by QUALCOMM ATHEROS.

In both cases, users can benefit from a specific feature: the entire TCP/IP protocol stack, as well as higher application protocols, i.e. HTTP, DHCP and DNS, are already integrated into the QCA4002. As a result, no profound knowledge concerning Wi-Fi is required during development, and users can focus on the core applica-

tion on their host MCU. Although the QCA4002 already comprises many RF components, many customers are shying away from the expenses of having their own RF designs, as well as final calibration and certification procedures. In order to lighten this burden, the company WISTRON, which closely cooperates with QUALCOMM ATHEROS, offers a module called DNSA-141, which is based on the QCA4002 and has therefore inherited all its outstanding features.

egrated into the QCA4002, such as the Low Power Listen, Green Tx Power Saving or the IEEE Sleep Mode.

No matter which solution you choose, whether the QCA4002 or the DNSA-141, with CODICO you can rely on a competent and experienced partner for your Wi-Fi design.

Please contact us at:

A01

▶ André Ehlert, +49 89 1301 438 11
andre.ehlert@codico.com

DNSA-141

- > QCA4002 based Wi-Fi module
- > 2.4GHz Single-Band IEEE 802.11b/g/n
- > Internal PA & LNA, no external RFSW
- > Green Tx Power Saving, Low Power Listen and IEEE Sleep Mode
- > On board printed antenna or IPEX-connector
- > Single power supply: 3.3V
- > Integrated IPv4/IPv6 networking stack
- > Full security support: SSL, WPS, WPA, WPA2, WEP
- > Integrated services: HTTP, DHCP, DNS, ICMP, IGMP
- > Easy to use UART or SPI host interface
- > 25mm x 20mm size, 2-layer, single side component
- > Operation temperature: -40°C – 85°C (Industry Class Version)
- > Regulatory compliances: CE, FCC and IC

Measuring only 20mm x 25mm, the certified module can be as easily connected via SPI or UART to a host MCU as the QCA4002 itself, however it does not require an RF design, calibration and final product certification. This module also supports the low-power features in-

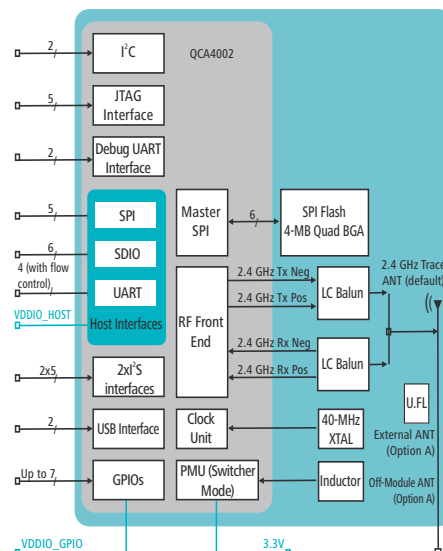

PLC BUNDLE



Since a year now, CODICO offers the QCA7000 which is the worldwide first HomePlug Green PHY Chip (HP GP). In the meantime, this chip became the standard solution for communication between electro vehicle and charging station and is used by many European car manufacturers in their electro and plug-in-hybrid cars as well as in the related charging stations.

Now it is time to address new market segments.

But the development of Powerline Communication (PLC) solutions puts interested users and developers in front of new challenges. One of the biggest is to understand the mode of operation and functionality of HP GP PLC technology and to proof the concept in reality without spending too much of R&D investment upfront. Another challenge is the real hard and software development process during which one need to compare with a reference system several times.

With the PLC Bundle for Internet of Things developed by I2SE most of the hurdles can be eli-



© kelly marken - Fotolia.com

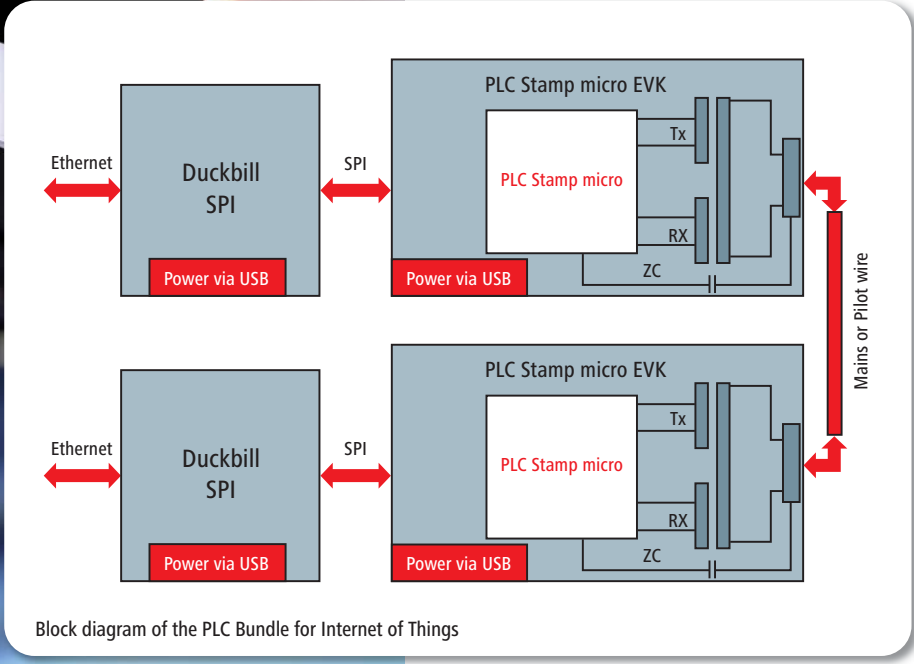

Block diagram of the PLC Bundle for Internet of Things

FOR INTERNET OF THINGS

minated. On the one hand side it offers operational PLC network nodes out of the box and on the other side it forms the basis for the development of own hard and software. This is possible because the bundle has a modular system setup consisting of host computers and evaluation kits.

To directly setup a network, the bundle consists of two identical sets. A small Linux computer is used as host controller and is implemented in form of a USB stick, called Duckbill SPI. The host controller is connected with the evaluation module via a flat cable. The components communicate electrically via SPI interface and are both powered by USB.

The evaluation module can be connected together either via the 230V mains or alternatively via any 2-wire connection.

The Duckbill SPI are supplied with a Debian Linux on a micro SD card in which the drivers for the communication with the QCA7000 are already have been integrated. They are connected to the Local Area Network by their Ethernet interface. One can start his software development on his PC right away. In this the Duckbill SPI provide a transparent bridge from Ethernet to SPI.

For users who intend to run their application on the Duckbill SPI directly I2SE offers a Virtual Machine (VM) development environment. The host processor in Duckbill SPI is a Freescale i.MX283 and is the same as used by QUALCOMM Atheros in their reference design and evaluation kit called »PL16«.

In order to support different applications the evaluation module is equipped with two different signal transformers. One for electro vehicle charging (winding 1:1:1) and the other one for home automation applications (winding 1:5:4). Transformers are selected by setting jumpers.

To protect users against electrical hazardous voltages relevant parts of the evaluation module

are covered by a transparent plastic shielding. The evaluation module might also be used without Duckbill SPI to be connected to other host systems. In this case easy QCA7000 driver development for different host controller systems can be performed.

The bundle allows to setup a two node PLC network right away. In order to develop own hardware in a second step the bundle contains two additional »PLC Stamp micro« modules. The micro modules can be soldered into the users PCB like SMD components. Besides the QCA7000 chip it contains all relevant filter components as well as the oscillator and the Flash memory.

The bundle will be delivered with all cables required.

Technical documentation and software for the PLC Bundle for Internet of Things can be found under www.i2se.com/devtools or contact Werner Reis.

A02

▼ Werner Reis, +49 8141357264
werner.reis@codico.com

©Petar - Fotolia.com



Components of the PLC Bundle for Internet of Things

MPQ4569

With the MPQ4569, MONOLITHIC POWER SYSTEMS offers a new synchronous step-down converter for input voltages from 4.5V to 75V and load currents up to 300mA.



The MPQ4569 combines high efficiency over a wide load range and a broad input voltage range as well. There's an adjustable Soft Start and a Power OK signal, and users can also take advantage in their applications of the reference from 1.0V ($\pm 1\%$) up to 100 μ A.

The EN pin allows the converter to be put in circuit with a defined source voltage using a voltage divider, with the switch-on threshold having a hysteresis of 22%. The adjustable Soft

Start is particularly useful in applications with a high internal resistance of the source.

Thanks to the low working quiescent current of only 20 μ A, this IC is ideal for applications in 24V automobile on-board networks, which still have to provide certain functions even when the ignition is switched off. The MPQ4569 is available as the AECQ100 G1 version. Another range of application for the MPQ4569 is in industrial systems with functional safety in

accordance with IEC61508/SIL. The IC is also a very good solution for the supply of μ C and cell-monitoring circuits in multi cell Li-XX battery systems. For these systems, the combination of high input voltage and a quiescent current in the range of a quarter of the self-discharge current of typically 18650 cells is an important factor.

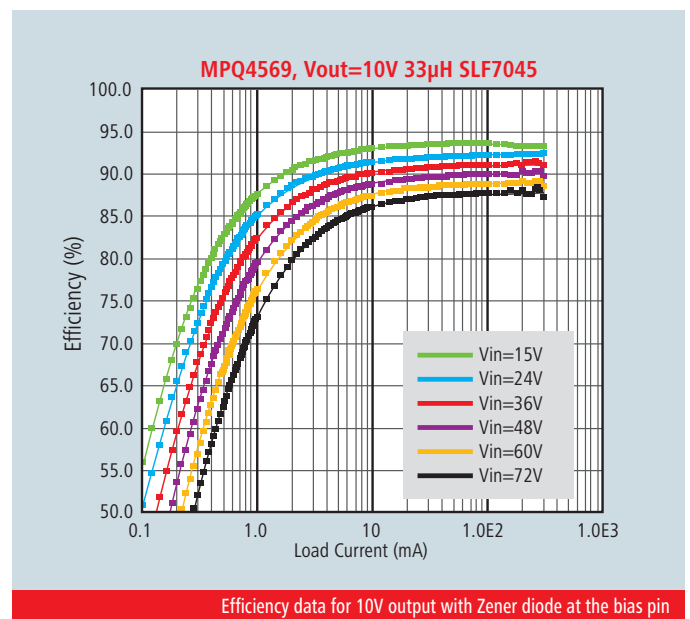
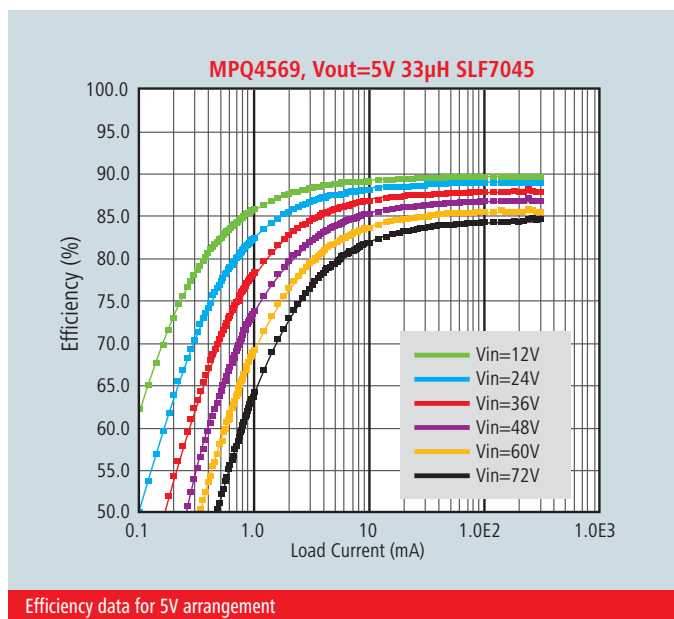

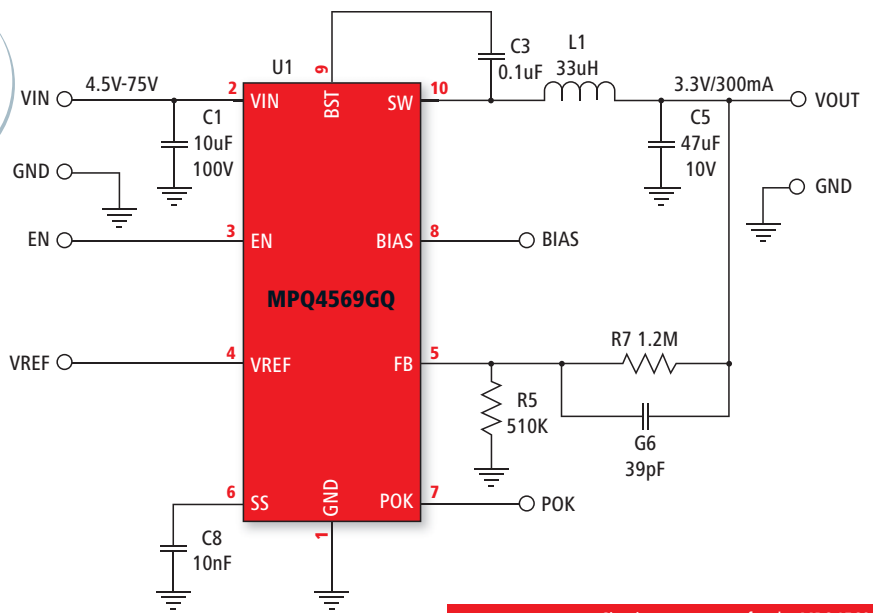
Circuit arrangement for the MPQ4569

The MPQ4569 can deliver up to 300mA to small non-isolated PoE systems

With an output voltage of 5V, the MPQ4569 achieves efficiency values of 84% to 90% for loads from 10mA to 300mA and input voltages from 12V to 60V. To achieve high efficiency over a broad load current and input voltage range the MPQ4569 uses a hysteresis »peak current mode« procedure. If the voltage at the Fb pin falls below the reference voltage, the upper MOSFET is switched on until the current in the switch and the coil has reached the peak value of 700mA. The upper MOSFET then switches off, and the lower MOSFET switches on until the current in the coil drops to zero. Depending on the output load the time interval of these switching cycles varies; in other words: the effective switching frequency is determined by the load current, the input/output voltage ratio, and by the value of the inductivity.

$$T_{ON} = \frac{L \cdot I_{pk}}{V_{in} - V_{out}}; T_{OFF} = \frac{L \cdot I_{pk}}{V_{out}} \text{ with } I_{PK} = 0.7A$$

The recommended minimum value of the inductivity is:

$$L_{min} = \frac{V_{in, max} \cdot 0.15 \mu s}{0.7A}$$

For 24V systems with a maximum input voltage of 30V the value is 6.5µH, and for the maximum permissible input voltage of 75V it is 16µH.

If highest possible efficiency is needed at very low mA load current, a higher inductivity value – in the 100µH range – should be used. This circuitry arrangement for the MPQ4569 will reduce switching losses in relation to the power output. And with high input voltages the efficiency at small load currents can be improved still further by feeding the bias pin of the MPQ4569 from the output with a voltage of between 2.9V and 5.5V.

With output voltages of more than 5.5V, for example, a Zener diode can be connected bet-

ween the output and the bias pin. As an alternative, the voltage can also be drawn from another part of the circuit.

For applications with an input voltage up to 45V and loads up to 100mA MPS offers the MPQ4568. Its adjustable peak-current makes this part is ideal for powering sensors in 2-wire sensor-systems (e.g. 4mA – 20mA).

A03

▶ Thomas Berner, +49 89 130 143 815
thomas.berner@codico.com

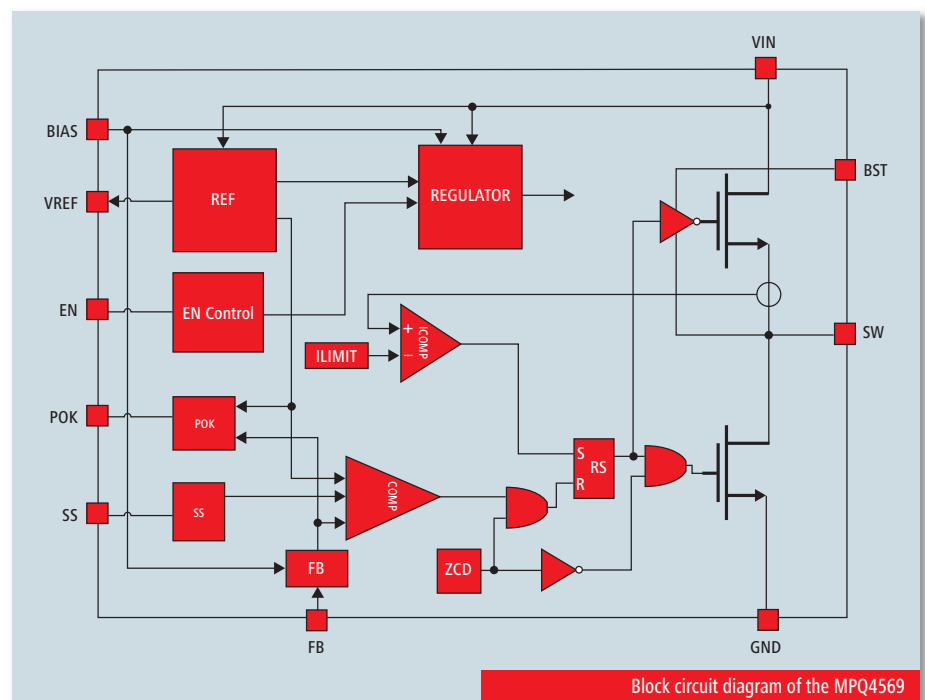

Block circuit diagram of the MPQ4569

XCL101: Ultra Low Power Step-Up Micro DC/DC Converter

Integrated Coil!



The XCL101 series is a step-up micro DC/DC converter with integrated coil in an ultra-small 2.5x2.0x1.0mm CL-2025 package.

As the basic DC/DC chip, TOREX uses there popular XC9140. A stable and efficient power supply circuit can be configured by simply adding only two ceramic capacitors externally, thereby contributing to PCB space saving and the shortening of development time. Able to start operation from input voltages as low as 0.9V, the XCL101 is suitable for use with single alkaline or nickel metal hydride cells.

**Converter with-
High Speed Soft-
Start Function**

Like all step-up DC/DCs, the output current that the XCL101 can supply will depend on the (V_{IN} , V_{OUT}) conditions, but up to 100mA of output current can be supplied with $V_{IN}=1.8V$ and $V_{OUT}=3.3V$ and with a $V_{IN}=0.9V$, more than 50mA is possible. With a quiescent current of only 6.3µA (Typ), reducing to 0.1µA (Typ) during standby, the XCL101 helps to maximise battery life in portable applications in addition to saving PCB space.

The XCL101 series also features a load disconnect function that prevents the battery charge from leaking to the output while the IC is not operating (XCL101A) and an Input by-pass mode function type is also available to keep the connection between the input and output side during shutdown (XCL101C).

In addition, a built in inrush current protection circuit suppresses inrush current spikes at start-up which results in a more stable power supply which in turn extends battery life. The input voltage range is from 0.9V to 5.5V and the output voltage can be selected, in 0.1V steps, within a range of 1.8V to 5.0V.

A05

▶ Johannes Kornfehl, +43 1 86305 149
johannes.kornfehl@codico.com

XCL211/12: 2A Step-Down Micro DC/DC Converter

The XCL211/12 series is an ultra small step-down micro DC/DC converter with an integrated coil that achieves a level of miniaturization and profile reduction that is one of the smallest in class for a load current of 2A.

With the integrated inductor, this new series is designed to minimise EMC emissions and radiated noise, whilst maximising efficiency. The operating voltage range is from 2.7V to 6.0V and the output voltage can be set freely from 0.9V to V_{IN} using external resistors.

The XCL211/212 series include a 1ms (typ.) high speed soft-start function for quick turn-on, a chip enable pin to turn the IC on and off and a CL discharge function to quickly discharge the output capacitor when the IC is turned off.

A thermal shutdown circuit is also built in which shuts down the IC once the chip temperature reaches 150°C and re-starts it when the temperature drops to 130°C (TYP.) or less. Available in a USP-11B01 package (3.1mm x 4.7mm x 1.3mm).

A04

▶ Johannes Kornfehl, +43 1 86305 149
johannes.kornfehl@codico.com

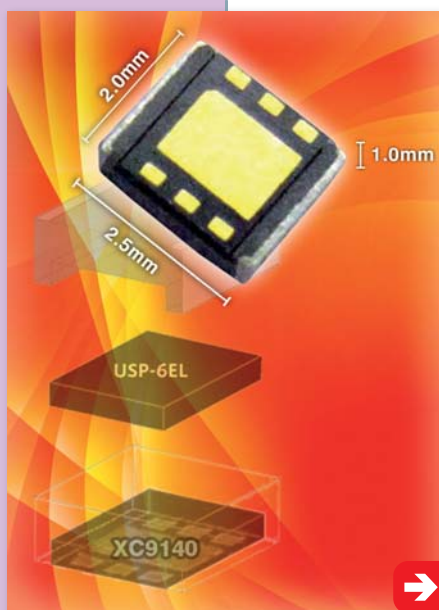

XC9306: 6MHz Synchronous Buck-Boost DC/DC Converter

Providing a regulated output voltage from an input supply that can be higher or lower than the output voltage, the XC9306 synchronous buck-boost DC/DC converter is ideal for lithium ion applications where the output voltage is within the battery voltage range.

A fully charged Li-ion battery starts at a high operating voltage, but as the battery is discharged its operating voltage declines to the point it can no longer provide sufficient voltage to power its load, even if some charge remains. The XC9306 can extend the usable life of a battery by boosting (stepping up) the output voltage to provide sufficient power to continue operation. This extends battery life by more efficiently using the remaining charge of the battery.

The XC9306 uses 6MHz switching frequency that allows for a smaller size inductor and capacitors, reducing the overall mounting area by as much as half. The buck-boost converter is based on a fixed frequency, PWM controller using synchronous rectification to obtain maximum efficiency. At low load currents, the converter can be switched over to PFM mode (MODE pin: L) to maintain high efficiency over a wide load current range. The input current can be limited to a typical value of 3.1, 1.3 or 0.49A. The output voltage is programmable using an external resistor divider.

The input voltage range is from 2.5V to 5.5V and the output voltage can be set externally, using resistors, within a range of 0.8V to 5.0V. Output currents up to 800mA can be supported. The XC9306 is available in an ultra small WLP-20 package which measures only 2.15mm x 1.94mm x 0.625mm!

A06

► Johannes Kornfehl, +43 1 86305 149
johannes.kornfehl@codico.com

XC9306 in a Tiny WLP-20 Package



TOREX
SEMICONDUCTOR LTD.



Model	TUHS3	TUHS5	TUHS10	TUHS25
Input Voltage	AC85V-264V (50/60Hz)			
Output Voltage/Current	5V 0.6A	12V 0.25A	24V 0.13A	5A 1A 0.45A 0.22A
Operating Temp.	40-85°C (Derating Required)			
Withstand Voltage	Input-Output	AC3, 000V 1minute Cutoff Current: 10mA		
Isolation Resistance	Input-Output	DC500V 50MΩ min (at room temperature)		
Agency Approvals	UL60950-1, C-UL, EN60950-1			
Conductive Noise*	FCC-B, VCCI-B, CISPR22-B, EN55011-B, EN55022-B			
Case Size**	28.7x17.5x12.7	28.7x17.5x12.7	33x22x15	36x25.4x16.5

*Connecting with the recommended circuit, **WxDxH, excluding external components)



The Midget!

COSEL introduces the smallest standby power supply available on the market today. The single output converter comes in four power ratings 3/5/10/25W with three different output voltages 5/12/24VDC.

Despite its compact dimensions the print module is suitable for industrial applications with ambient temperatures ranging from -40 to 85°C. The class II converter is approved according to EN60950-1, cUL and UL and meets EN55022 Level B. Worldwide usage due to an input voltage range of 90-264Vac at 50/60Hz makes it the perfect companion for countless applications.

Its dimensions are tiny: 28,7mm x 17,5mm x 12,7mm at 3 and 5 Watt and 36mm x 25,4mm x 16,5mm at 10 and 25 Watt.

The midget limits its no-load power consumption to 0,5W and complies with the ErP 2009/125/EC. The module comes with remote control to enable the main output. The TUHS is a perfect drop in standby power supply to control a main circuit and make the complete application – simply - greener!

A07

► Andreas Hanausek, +43 1 86305131
andreas.hanausek@codico.com





COMPLETE!

COSEL®

With the 480W version of the KH series being released (as announced in the Impulse issue 2/2013), COSEL – the Japanese high-end manufacturer – offers a complete portfolio of DIN Rail Power Supplies ranging from 30-480W.

the housing supporting natural convection. The ambient temperature is specified up to impressive +70°C with little power derating. Fast assembling in the cabinet is achieved by the standard snap-in clips along with countless approvals (UL60950-1, C-UL (CSA60950-1), EN60950-1, EN50178, UL508 (Industrial Control Equipment), ANSI / ISA12.12.01; GL Maritime Approval) enabling carefree usage in multiple applications. Screw mounting as an option for assembling the power device on a plate rather than a Din Rail genuinely suitable to any industrial application – even if there is no cabinet available.



Custom labelling is available by COSEL from quantities of 500pcs.+ per year – for free. The innovative, cost-optimized design assures highest reliability which is strengthened its five-year warranty without any additional charges. The whole line up is available with 24VDC nominal output voltage, with 5 and 12VDC being on their way.

A08

▶ *Andreas Hanausek, +43 1 86305131
andreas.hanausek@codico.com*

The key feature of the all new KH series is a 1.5 peak capability (available from 120W nominal output power) – ideal for inductive loads with high inrush current (e.g.: motors). »Plug and Play« made easy by using the Remote on/off interface making the need for an additional relay obsolete, similar to the »Power-Good« signal (DC »ok« signal available via screw terminal; LEDs for DC »ok« and ALARM = output voltage decreasing). Optional conformal coating (lacquer coating) for rugged industrial environment together with the highest in class efficiency of typical 94% equals smallest form factor due to less heat dissipation – achieved by an optimized component distribution inside

Basic characteristics

Installation	Single Phase – Class I: FG / N / L
Input Voltage	85 – 264VAC (47-63 Hz) or DC: 120-370V
Output Voltage Adjustment	22,5 – 28,5VDC
Output Current (Peak load avail. for 5 sec)	1,3A / 2,5A / 3,8A / 5(7,5)A / 10(15)A / 20(30)A
Efficiency (typical)	94%
Operating Temperature	-25°C ...+70°C (linear derating from 50°C)
Control Interface	Remote on/off (TTL 0-0,5 / 4,5 – 12VDC)
Signal contact	DC-O.K. relay (0 / 1)
Signal LED	DC-O.K. relay
Protection	Over-Voltage, -Current, -Temperature
Options	Custom specific
Approval	UL60950-1, C-UL (CSA60950-1), EN60950-1, EN50178, UL508 (Industrial Control Equipment), ANSI / ISA12.12.01, GL Maritime Approval

GO BEYOND —

3 Phase Din Rail Series for industrial applications

The newly branded ARTESYN Embedded Technologies – previously known under Emerson Network – adds new models to their three phase range with 5 and 10A versions. The ADN family comes with five year warranty, astonishing efficiency and an impressive 500khrs+ MTBF. The complete range from 120W up to 960W addresses industrial applications where no Neutral is available.

Designed to operate direct from standard three-phase inputs, the new ARTESYN Embedded Technologies ADN-C series power supplies have a wide 320 to 540VAC input range, capable of accommodating virtually all standard line voltages worldwide. They are also capable of operating from a dc input, in the range 450 to 760Vdc. The power supplies are very high efficiency designs – typically 94 percent – and also employ advanced active power factor correction techniques to further maximize efficiency and help minimize running costs. They can accommodate phase loss, automatically shutting down if thermal thresholds are exceeded under this condition.

All new ADN-C series power supplies produce a single 24VDC output, which is user adjustable up to 28VDC. The output is tightly regulated to within plus or minus 2 percent for all normal line, load and temperature conditions, and ripple is held to less than 100 mVpp.

Each power supply can also easily be paralleled for higher current operation using a front panel switch; the ADN40-24-3PM-C uses active current balancing to ensure load equality and maximum efficiency. A PowerBoost facility overcomes the disadvantage of output fold-over under the high peak current demands of switching large inductive loads, such as heavy duty relays, solenoids or motors. This can result in the device failing to activate or start. PowerBoost provides 1.5 times the supply's nominal current for a minimum of 4 seconds, while maintaining a 20V output to ensure successful operation.

EMERSON Network Power ADN-C power supplies are industrial-grade designs, housed in rugged IP20-rated metal cases. A special metal clip allows fast and secure snap-on DIN rail mounting, without tools. All electrical connections

are made via easily accessible front panel screw terminals. The whole family has exceptional slim form factors depending on system configuration, this can save as much as 45 percent valuable DIN rail space, conveying significant layout and wiring flexibility – and often enabling further function modules to be accommodated on the same DIN rail. The power supplies have a nominal full load operating temperature range of minus 25 to 60 degrees Celsius without derating, and are intended for fanless convection cooling.

They are extensively protected against overvoltage, overload and continuous short-circuit conditions, and have a power-back immunity of more than 35V. Front panel LED diagnostic indicators continuously monitor eight separate input, output and alarm conditions, instantly showing any change of status. A »DC OK« relay output is also provided, for remote diagnostics and condition monitoring purposes.

ARTESYN Embedded Technologies ADN-C power supplies meet all applicable international EMC emission and immunity standards – including the Semi F47 sag immunity standard for semiconductor fabrication equipment. The designs also comply with the EN 60950 Low Voltage Directive and the Restriction of Hazardous Substances (RoHS). Comprehensive safety approvals include UL 508 and UL/IEC 60950-1.

The power supplies are additionally approved for use in Class 1, Div 2 hazardous locations. They designed for high reliable applications and have a demonstrated mean time between failure (MTBF) of 450,000 hours, and are backed by a comprehensive five year warranty.

A09

▶ *Andreas Hanausek, +43 1 86305131
andreas.hanausek@codico.com*



POWER SUPPLY FOR CRITICAL MEDICAL APPLICATIONS



DEGREE OF PROTECTION AGAINST ELECTRICAL SHOCK (APPLIED PARTS)

TYPE B: No electrical contact with the patient. Usually earth-grounded: Class I

TYPE BF: Electrically connected with the patient but not directly to the heart. Floating ground. Class II

TYPE CF: Electrically connected to the heart of the patient. Floating ground.

EOS introduces (M)WLT450, the latest member of its WLT series, a medical and industrially certified U-channel power supply on a 4x6.5x1.5" footprint.

With forced air cooling, the unit can deliver up to 450W (300W with convection cooling) continuously and up to 500W for 5s withstand short peak loads. Auxiliary outputs with 5VSB and 12VDC for the fan are just two on a long list of features (Power Good, Remote Sense, Remote on/off).

A front-end version with fan and IEC 320 input connector is provided for easy installation. Other designs, e.g. with a side fan, are also available. But that's not all: contrary to other power units of its class, the (M)WLT450 comes with the ORing MOSFETs already installed. This allows not only parallel but redundant operation – without any additional wiring. Hence, the parallel-connected power supply will continue to work unimpeded following an operational failure e.g. a short circuit at one output.

The »green approach« finds its way into both industrial and medical applications. Even if the ErP Directive (2009/125/EC) does not yet apply

to such applications, all renowned manufacturers are gradually preparing for it. Though not easy to implement from a technical point of view, the standby power consumption of the (M)WLT450 is a mere 0.8W at an input voltage of 230VAC; with an impressive efficiency of up to 90%. The new (M)WLT450 series is certified in accordance with EN60601 3rd Edition (2x MOPP) and EN60950 2nd Edition.

The extremely low leaking current of the medical version sets it apart from its competitors. The so-called »touch leakage«, i.e. the »patient leakage current«, the current measured from any applied part to ground, is 45µA max. In ad-

dition to the double fuse protection at the input, the device is compliant to the requirements for BF (body floating) rating. As a result, the unit is now suitable for all applications involving direct patient contact.

A10

▶ *Andreas Hanausek, +43 1 86305131
andreas.hanausek@codico.com*

Leakage Current mA (AC)	Type B		Type BF		Type CF	
	NC*	SFC**	NC*	SFC**	NC*	SFC**
Earth	0.5	1	0.5	1	0.5	1
Earth for exed equipment	5	10	5	10	5	10
Enclosure	0.1	0.5	0.1	0.5	0.1	0.5
Patient	0.1	0.5	0.1	0.5	0.01	0.05

*NC: normal condition, **SFC: single failure condition

FULL POWER UNLEASHED!



After the unrivalled success of the smallest in class 3x5" power supply with 600W output power, VOX Power introduces the Nevo+600's big brother – the Nevo+1200.

Impressive 1200W on just 6x6" and 1U result in a total power density of 22W per cubic inch – throughout its input voltage range starting from 120VAC and any output configuration. The all new Nevo+1200 comes with eight independent output slots that may be assembled and combined as you wish.

The five available single output modules cover all voltages from 1.5 up to 58VDC and adjustable over current protection, Power Good and Inhibit on the Mainframe plus I2C Control for all output modules. In addition three dual output modules (non-bipolar) are available off the shelf. Additional features such as »Series Tracker« for applications requiring sequencing and an improved I2C module (resolution ± 127 for current and voltage) for an easy system integration. Custom specific and standard cable assemblies are available on demand. All output modules may be connected in series and parallel. Sensing allows a very easy (active) current sharing.

Smart fans minimize the acoustic noise emitted from the power supply, decelerating its speed and increasing lifetime. The Nevo+1200 Fron-

tend is not just two Nevo+600 but a new front-end developed from scratch. It's not only for that reason why its radiated noise complies with EN55022 Level B radiated but also a commendable no load power consumption below 5W.

The rework of the 1.200W version is – dependant on its version – approved according to

EN60950 (2nd Edition) and EN60601 (3rd Edition) and allows a diverse usage in medical and industrial applications.

A11

▶ *Andreas Hanausek, +43 1 86305131
andreas.hanausek@codico.com*



LITTLE GIANTS

SILVERTEL's new PoE Range

Ag9700-FL

SILVERTEL's Ag9700-FL series are fully featured PoE PD modules designed to give a high performance low cost alternative to the existing product range. They extract power from a conventional twisted pair Category 5 Ethernet cable. These modules conform to the 802.3af Power-over-Ethernet (PoE) standard and offer 1.5kV isolation, PoE signature and integral DC to DC converter. The module allows the power classification to be set. The modules provide a simple PoE solution using minimal extra low cost components. Ag9700-FL will accept power from either the spare or data pair of the Ethernet cable, enabling the device to be powered from mid- or end-span PSE.

The integrated optimised DC/DC converter operates over a wide input voltage range providing a high efficiency regulated low ripple output. In addition it provides built-in protection against overloads, over temperature and short-circuits. There are three nominal output voltage options: 3.3V, 5V and 12V. These are easily adjustable using a simple pull up/down resistor.

SILVERTEL launches a cost optimized IEE802.3af compliant PoE PD converter with industrial temperature rating and improved performance. The all new Ag9700-FL series complements the latest designs AG-9800-M, the smallest ever SMT PoE converter on the market and the Ag5300, a cost and size optimized PoE + PD converter.

The Ag9700-FL includes on-board diode bridges and provides signature and control circuitry to give full PoE compatibility. This signature is required by the Power Sourcing Equipment (PSE) before it will provide power to the port. The modules are designed for industrial temperature

with an operating ambient temperature range of -40°C to +85°C.

Ag5300

SILVERTEL's Ag5300 is the first PoE+ module delivering up to 30 Watt of output power that

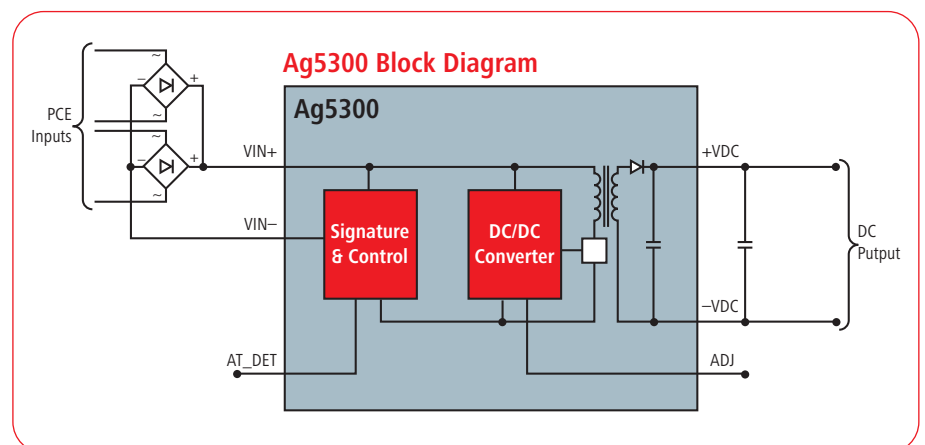

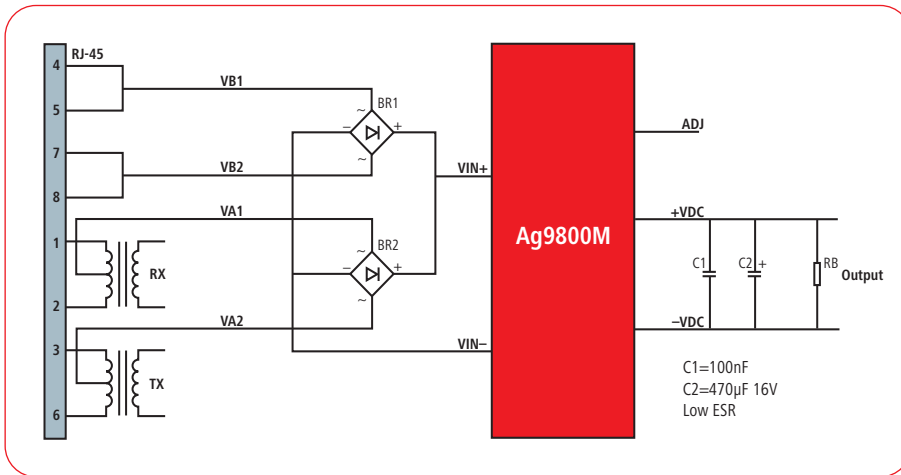

Ag5300 includes 1500V safety isolation as required by IEEE802.3 and to help prevent earth loops.

The module is designed for simple integration, requiring the addition of just a few low cost components (two diode bridges and an electrolytic capacitor on the DC output).

Ag9800

Despite its tiny dimensions the Ag9800 is a fully compliant PD (Power Device) PoE module and allows power extraction from a standard Cat5 Ethernet cable. Fully compliant to IEEE802.3af offering an isolation (input/output) of 1.5kV by integrated DC/DC converter. The smallest ever PoE PD Module has already been introduced in the »Impulse 2-2013«.

A12

► *Andreas Hanausek, +43 1 86305131
andreas.hanausek@codico.com*

requires less than 10.3cm² of PCB space. This is ideal for any applications where space is at a premium, such as IP Telephones, Wireless Access Point, PTZ camera, door entry system and remote computer terminal applications.

Ag5300 is compatible with both the IEEE 802.3af and 802.3at standards for signature recognition. The Ag5300 classification is fixed at Class 4.

The module works with both types of Power Sourcing Equipment (PSE) units - mid-span and end-span injectors. The high efficiency DC/DC converter operates over a wide input voltage range to provide a regulated low ripple, low noise output. The module provides built-in overload, thermal and short-circuit output protection. The output voltage is programmable for values between 10.8V and 12.8V.

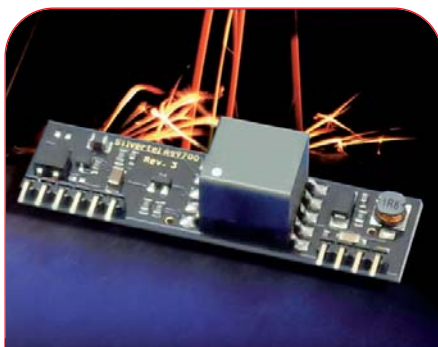

Ag9700-FL: IEEE802.3af compliant PoE

- > Small SIL package
56mm x 18mm x 14mm (LxWxH)
- > Low output ripple and noise
- > Class Programming
- > Industrial temperature
- > Overload, thermal and short-circuit protection
- > Wide input voltage range
- > 3.3V, 5V or 12V output options
- > 1500V isolation (input to output)
- > Integral DC/DC converter
- > Simple integration



Ag5300: IEEE 802.3af and at-compliant PoE

- > SIL - 57mm x 18mm x 14mm (LxWxH)
- > Up to 30 Watt Output Power
- > High efficiency DC/DC converter
- > Adjustable output voltage
- > 1500V isolation (input to output)
- > Input voltage range 37V to 57V
- > Minimal low cost external components required
- > Overload, thermal and short-circuit protection
- > Simple integration



Ag9800: cost optimized fully compliant to IEEE802.3af PoE

- > Smallest available form factor
28 x 17,8 x 12mm (LxWxH)
- > Overload and short circuit protection
- > Input voltage 36 - 57VDC
- > Output Power up to 12 W at 12, 5 and 3,3 Vdc
- > 1500 V I/O isolation
- > Integrated DC/DC Converter
- > Simplest integration

 **Silvertel**



LANTIQ and CODICO signed a pan-European distribution agreement covering almost all European countries.

LANTIQ is a fabless semiconductor company specializing in broadband communications, next generation networks and the digital home including analog, digital and mixed-signal ICs as well as complementary comprehensive software suites and has a 20+ year record of technology leadership and innovation.

The company's core expertise is its ability to combine world-class mixed signal and digital signal processing to deliver innovative system partitioning and very high level system-on-chip integration. LANTIQ's advanced SoC (System-on-Chip) solutions address a wide variety of technologies, including all flavors of xDSL, VoIP, Wi-Fi, FTTH, Gigabit Ethernet and LTE and have allowed LANTIQ to become the number one supplier of access network integrated circuits.

As one of leading provider in telecommunication ICs LANTIQ is an excellent addition to CODICO's Linecard.

AT CODICO

High Data Rates over Long Copper Pairs: Lantiq SOCRATEST™

Nothing beats SHDSL when it comes to high data rate requirements on long copper loops. A global ITU standard, SHDSL stands for Single-Pair Highspeed Digital Subscriber Lines.

In more than a decade of use, equipment providers and carriers have gone beyond the »single-pair« concept to achieve higher data rates, and specialized modes of operation have extended the reach of SHDSL lines.

Today, LANTIQ offers SHDSL-based transceivers that enable data rates up to 15 Megabits per second (Mbps) per copper pair and reach far beyond 10 kilometers. With the Lantiq SOCRATEST™ single-chip solution, adding kilometers of TDM or Ethernet connectivity be-

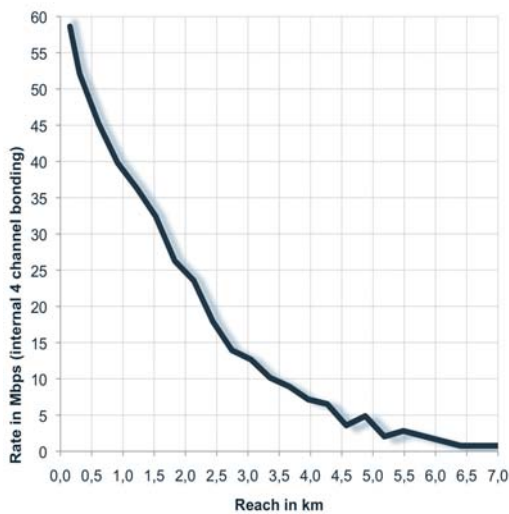

Rate/Reach Performance Measurement of Lantiq SOCRATES™-4e V1.2

comes as easy as adding a generic Ethernet Phy. The chip features standard MII and TDM interfaces and a 4-pair bonding engine that enables up to 60Mbps throughput over 4 copper pairs (e.g. 4 telephone cables or one CAT5).

Fifteen years after its first market introduction as broadband access technology for businesses, SHDSL has gained a second life in industrial applications. It is the technology of choice whenever long copper cables are already deployed or required, e.g. for remote power feeding. More and more industrial applications rely on SHDSL as a robust long-reach communication technology. Examples are surveillance cameras, vending machines, public displays, infotainment systems, traffic control and industrial sense and control applications. And even the traditional business access segment offers growth opportunities in regions without fiber infrastructure. For hotels, offices and shops out of fiber-reach, SHDSL service providers can offer 100Mbps symmetrical rates over bonded phone lines, a tremendous value-add to the copper access infrastructure.

In recent years, Lantiq SOCRATES™ has become the de-facto standard and synonym for SHDSL communication. It is by far the most innovative product in the market and has gradually gained a very strong market position. Its worst case power consumption of 650mW per line is only half that of the nearest competitive product. Digital and analog front ends are combined in one single 19mm x 19mm LPGA package and

require only two supply voltages. On top of that, SOCRATES™ does not require separate memory and can be configured with a simple 8-bit micro controller. An integrated bonding engine distributes data streams from TDM, UTOPIA, MII and SS-MII interfaces to up to four SHDSL lines; in Dual Bearer Mode, TDM data and Ethernet packets can even coexist on the same lines. LANTIQ continues to invest in the SOCRATES™ business line. Future proof manufacturing processes and frequent firmware updates guarantee long-term availability, which is critical particularly in industrial markets.

The core standard ITU G.991.2.bis (G.SHDSL, Single Pair High Speed DSL) specifies data rates up to 5.7Mbps per line and 23Mbps with 4-pair bonding. A second relevant standard, IEEE 802.3ah (EFM, Ethernet over First Mile) specifies SHDSL-based Ethernet Phys for loop lengths beyond 750 meters. Lantiq SOCRATES™ is 100% G.SHDSL and EFM standard compliant and offers best in class interoperability. But this isn't where it ends. LANTIQ goes beyond the standards and offers proprietary modes with substantially enhanced rate-reach performance. Using one SOCRATES™ on each end, symmetrical rates up to 60Mbps are possible. Typical rate/reach characteristics are shown in the diagram above. Reach can be extended further on thicker copper cables. For example, 300kbps



Lantiq SOCRATES™-4e V1.2

data rates can be achieved on one 1.4mm radius copper pair over 50 kilometres!

Today, hundreds of Lantiq SOCRATES™ based applications are readily available in the market. New applications benefit from the maturity of the technology, the rich experience of design houses around the world and the unique LANTIQ SHDSL tech support. New SHDSL designs have record time-to-market. Three months from start to volume ramp are not unusual. Lantiq SOCRATES™ systems provide unique reach/throughput performance out of a powerful single-chip solution.

A13

▶ Werner Reis, +49 8141 357 264
werner.reis@codico.com





Gigabit Ethernet PHY for industrial applications

Main features of the XWAY™ PHY11G:

- > Single supply voltage of 2.5V or 3.3V
- > Power dissipation as low as 160mW at 100 Base-T and 400mW in 1000 Base-T mode; in idle mode even 100mW only
- > Support of Energy Efficient Ethernet Pre-Standard (IEEE802.3az) and with that power dissipation reduction of up to 40%
- > Power saving features »Wake-On-LAN« and »Auto-Power-Down Mode«
- > Pin strapping, means simple configuration of the chip by using the novel soft pin strapping feature available for the LED pins
- > Extended loop reach in Gigabit Mode of up to 120 metres
- > Support of cable diagnostics
- > Low area and low eBOM and with that low system cost

More and more industrial applications are using Ethernet with 1,000Mbps data transmission rate and are going to replace or upgrade the currently dominant 10/100Mbps variant.

Because of several reasons at Gigabit Ethernet speed the line adapting circuits – the PHYs – are not built into the controller and switches and are still externally. To address this market the new XWAY™ PHY11G Gigabit Ethernet PHY »PEF 7071« from LANTIQ is now available.

The yellow frame shows how compact the integration of the XWAY™ PHY11G design is and how less external components are required. The picture below shows the block diagram of the EASY 7071 Reference Board.

note from LANTIQ's web based customer portal. Besides other informations, it contains proposals for the external circuitry. By following this proposals a fast and assured design success are warranted.

A14

► Werner Reis, +49 8141 357 264
werner.reis@codico.com

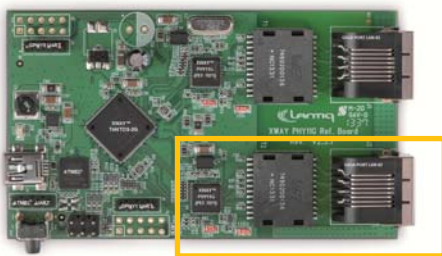

EASY 7071 Reference Board

The chip is housed in very small 7mm x 7mm, 48-Pin, Very Thin Quad Flat Non-leaded (VQFN) package and offers the most relevant interfaces RGMII and SGMII (Serdes up to 1.25Gbit/s interfaces available). With that, it supports the Ethernet functions 10 Base-T, 100 Base-TX und 1000 Base-T in copper applications.

On the board there are two full function transmission paths each equipped with XWAY™ PHY11G chip as well as an Ethernet Switch, which connects both paths. The board is powered via an USB interface.

To support a close to production implementation of the PEF 7071 design customers can download a reference design and application

PEF 7071 in copper application

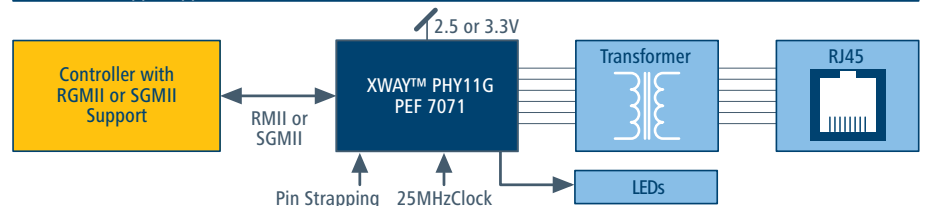

Block diagram of the EASY 7071 Reference Board

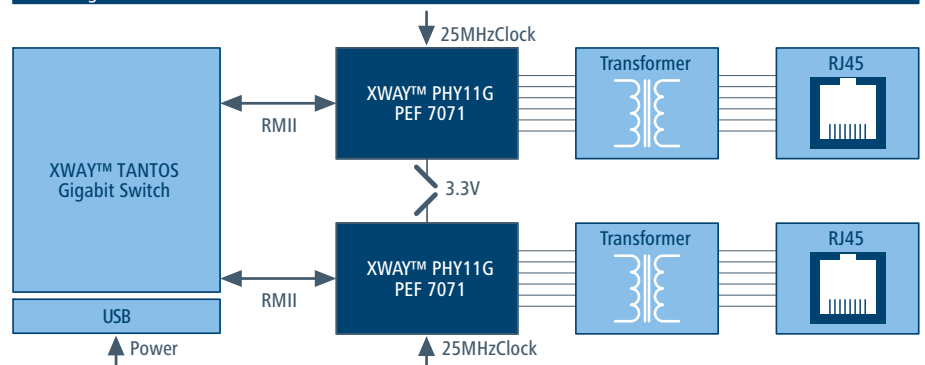

SAM D MICROCONTROLLERS



The new ATMEL »SAM D« family of microcontrollers builds on an ARM Cortex-M0+ core. In developing these products, ATMEL has drawn on long years of experience with the AVR series to create these new controllers, which are leading the way to the future. These products set a new benchmark in flexibility and simplicity in development work. The performance and energy efficiency of the ARM Cortex M0+ core has been combined with an optimized chip hardware and periphery, making these products ideal for many low-power and cost-sensitive industrial applications.

So what are the key functions of these ATMEL products?

The controller operates at up to 48MHz, and pulses the ARM Cortex M0+ core with its basic performance value of 2.14 CoreMark/MHz. Available peripherals are a single cycle I/O access, event system, DMA, internal and external oscillators, configurable communication modules, timer/counter, touch controller, RTC, ADC's, I2S and USB device and host. Particular attention has also been paid to compatibility within the sub-families. This means that it is easily possible to move between the different package variants; for example, with the TQFP package, the pins for the supply, the analog pins, etc. are always located on the same side flank of the package.

The product portfolio of the ATMEL »Sam D« family consists at present of four sub-families. The smallest modules are grouped in the »SAM D10« family, and the largest at the present time

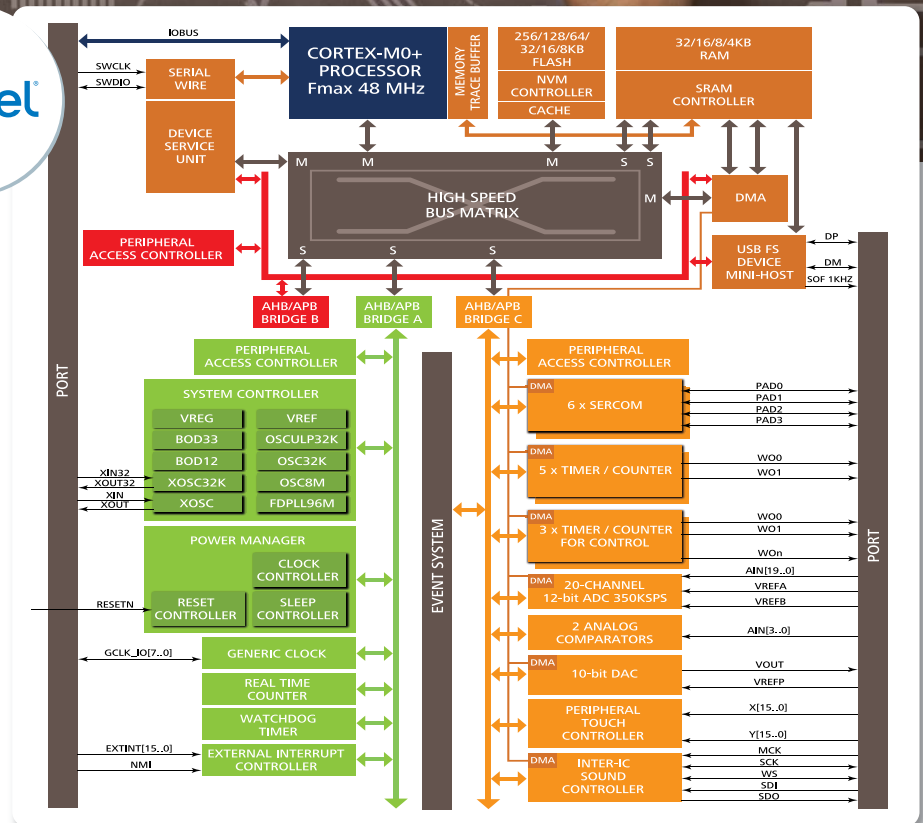

are known as the »SAM D21«. The graphic provides a good overview of the differences between them. The graphic uses some abbreviations which are specific to ATMEL:

SERCOM stands for Serial Communication Module. This is a module which can be converted by the user into a USART, I2C or SPI interface. The output pins on the package can also be selected by means of an I/O multiplexer for the respective interface involved, so increasing flexibility in the layout.

PTC stands for Peripheral Touch Controller. This is an interface which allows for simple implementation of capacitive touch buttons, sliders and wheels.

TIMER/COUNTER for Control is a special timer/counter module for use in power supply systems as well as applications in the light and motor control sectors. In these contexts, the module supports frequencies of up to 96Mhz, and also operates with up to 24 bit resolution.

For rapid implementation in the customer's design, the hardware available includes extremely economical Xplained Pro Boards. On the software side, ATMEL Studio is available as a fully integrated solution for programming and debugging. ATMEL Studio also supplies drivers and a huge range of examples.

A15

▶ Johannes Kornfehl, +43 1 86305 149
johannes.kornfehl@codico.com

SAM D FAMILY	SAM D10	SAM D11	SAM D20	SAM D21
Cortex M0+core, Event System, SERCOM, PTC, 12 Bit ADC, 10 Bit DAC, Analog Comp, RTC Timer/Counter, Watchdog, Internal RCs	8-16KB flash 14, 20 und 24 pins 6 channel DMA Timer/Counter for control	8-16KB flash 14, 20 und 24 pins 6 channel DMA Timer/Counter for control FS USB Device	16-256KB flash 32, 48 und 64 pins	32-256KB flash 32, 48 und 64 pins 12 channel DMA 3 Timer/Counter for control FS USB Host & Device I2S

First field-proven, turnkey software for

CARRIER-ETHERNET-DELIVERY



ABOUT VISAA: THE INDUSTRY'S ONLY SERVICE-AWARE ARCHITECTURE

ViSAA is a scalable, hardware-based, efficient solution for enabling MEF CE 2.0 Carrier Ethernet service delivery in networking equipment, including Ethernet Access Devices (EAD), Packet Transport Network (PTN) Access Equipment and Network Interface Devices (NID), used in micro cell, small cell and macrocell backhaul networks. For more details, visit www.VITESSE.com/visaa.

CEServices software paired with VITESSE service aware architecture (ViSAA) expedites OEM time to market by nearly 70%.

By 2017, analysts expect that bandwidth Ethernet business services will comprise over 75% of total bandwidth globally. Other recent reports estimate the Carrier Ethernet services market at \$38 billion in 2013 and forecast continued strong growth rates, with Enterprise Carrier Ethernet services revenue alone reaching \$62 billion worldwide by 2017.

»VITESSE's CEServices software has been vetted in multiple industry-wide interoperability events such as EANTC, with many of our customers seamlessly achieving MEF CE 2.0 certification during the first wave of 2013 MEF equipment certifications,« said Harpreet Chohan, product marketing director at VITESSE. »VITESSE remains committed to enabling low cost and low power MEF CE 2.0-compliant access platforms for Carriers to monetize Ethernet service delivery in mobile access and Cloud networks«.

Versatile software layer optimized for CE service delivery with ViSAA

CEServices software works in tandem with VITESSE's ViSAA-enabled Carrier Ethernet switch engines – Jaguar™, LynX™, Caracal™, and Serval™ – to simplify Ethernet business service provisioning and monitoring at greater scale and wire-speed performance with various standards-based capabilities including:

- > Service classification and MEF compliant policing to meet advanced Service Level Agreements (SLAs)
- > Performance monitoring and service activation measurements - RFC2544, Y.1731 and Y.1564
- > Multi-operator OAM - up and down MEPs
- > Extensive suite of Carrier Ethernet and MPLS/MPLS-TP networking protocols and
- > SyncE and IEEE 1588v2 PTP protocol support with VITESSE's VeriTime, the

industry's de facto highest accuracy IEEE 1588v2 synchronization technology.

For service subscriber Edge applications, such as SLAs, ViSAA Service Edge software control functionality enables per EVC, policers, shapers, queues, tagging and marking, statistics and extensive OAM to ensure traffic flow compliance. For network applications, CEServices software enables ViSAA networking functionality for provider bridge (Q-Q) tunneling. Traffic protection enables scalability, while ensuring reliability. CEServices also enables end point and immediate point access to MEF CE 2.0 capabilities and functions.

Learn more at www.VITESSE.com/ceservices.

A16

► Harvey Wilson, +44 1704231240
harvey.wilson@codico.com

SMALL, BLACK & POWERFUL: MPS DC/DC-MODULES

© absolutimages - Fotolia.com

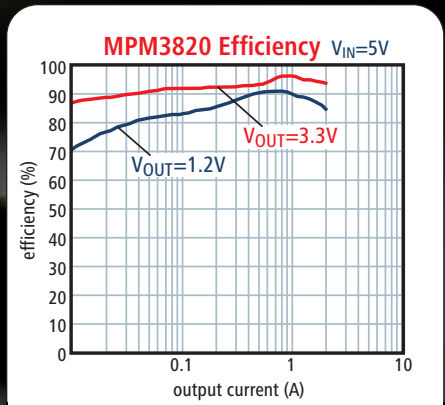

The most important parameters at a glance

- > 2.7V to 6.0V input voltage
- > Output voltage fixed or adjustable from 0.6V on
- > Synchronous COT DC/DC converter with integrated coil
- > Excellent efficiency, also at light load (70-90 %, depending on the output voltage)
- > 100% duty cycle in the event of dropout
- > Low I_q ($<40\mu A$)
- > Total space consumption only 8.5mm x 4.5mm
- > EN pin and Power-Good signal

Higher demands on system-efficiency are making life hard even for LDO solutions often used in the extra-low voltage range. An efficient alternative is the use of a switched DC/DC-converter.

Solutions with DC/DC-IC's are economical and effective, but they need a certain amount of external circuitry, and in particular a properly adapted coil. The layout needs to be carefully considered too, since in most cases switching frequencies between 500kHz and 4MHz are used. Complete DC/DC modules for print assembly are in most cases too expensive and consume too much space.

For this task the MPM-modules from MPS are designed. Thanks to the integration of a high-performance DC/DC-IC and optimized adjusted coil in one small SMD package only a few external components are needed: two capacitors and, if necessary, a resistive divider to adjust the required output voltage. The first generation of MPM modules cover the input voltage range from 5V (2.7V to 6.0V). Besides the already exi-

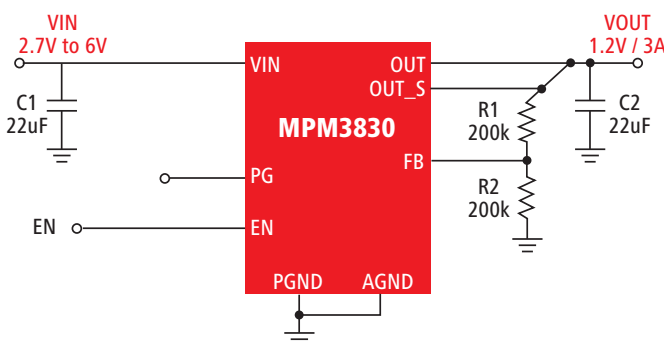

isting 0.6A and 1.2A modules two new modules are particularly interesting, the MPM3820 and MPM3830 with 2A respectively 3A of output current.

A17

▶ Thomas Berner, +49 89 130143 815
thomas.berner@codico.com

Part Number	Iout (A)	Vin (V)	Iq Current (uA)	Light Load efficiency	PG	SS	Protection Features OCP/SCP, UVLO/OTP	Pkg. Size (LxWxH)	Release Status
MPM3805	0.6	2.5-6	17	✓	✓	Int.	✓	3x2.5x0.9mm QFN12	Released
MPM3805 1.2/1.8/2.5/3.3V	0.6	2.5-6	17	✓	✓	Int.	✓	3x2.5x0.9mm QFN12	Released
MPM3810	1.2	2.5-6	17	✓	✓	Int.	✓	3x2.5x0.9mm QFN12	Released
MPM3810 1.2/1.8/2.5/3.3V	1.2	2.5-6	17	✓	✓	Int.	✓	3x2.5x0.9mm QFN12	Released
MPM3820	2	2.7-6	40	✓	✓	Int.	✓	3x5x1.6mm QFN20	New release
MPM3830	3	2.7-6	40	✓	✓	Int.	✓	3x5x1.6mm QFN20	New release

SILVERTEL MAKES WIRELESS POWER — SIMPLE!

Just add coils!

Wireless power is rapidly becoming a significant growth area, utilised in a surprising variety of applications. Volume growth is being driven by consumer appetite for battery powered portable electronic devices and the inconvenience of keeping them charged. As the rollout of devices capable of wireless charging continues to grow, wireless power will soon become an expected feature of modern devices and products.

SILVERTEL has launched its first modules in a new range designed to make introduction of wireless power and charging products simple. The new modules are based on the widely accepted and increasingly adopted Qi standard released by the Wireless Power Consortium back in 2009. Released as a complementary

transmit and receive power pair, the Ag311 and Ag301 modules are designed for Qi compliance and interoperability.

Qi based wireless power transfer works on the principle of magnetic induction, where two closely coupled coils transfer power between each other. It's the same principle that battery powered rechargeable electric toothbrushes have worked on for years! The coils can be aligned by simple placement (A10 type) or magnetically aligned (A1 type) for easy placement.

SILVERTEL offers a solution that delivers all the benefits of wireless power, including improved safety, with no cables or exposed contacts, in two easy to integrate modules. Full evaluation kits for both transmit and receive modules, including coils, as in the picture (Ag311 Eval), are readily available to trial and test this new exciting technology.

These modules are capable of delivering up to 5W of power to the receiver side, as per the first release Qi standard. SILVERTEL's modules are ideal for medical, industrial, scientific or commercial applications requiring a robust wireless charging design that is easy and quick to implement. Plans are already in place for higher power versions of Qi, starting with a 15W solution and moving on to a 120W solution.

SILVERTEL's Ag311 wireless power transmitter is based on a Qi type A1/A10 half-bridge based solution, single coil with or without an aligning magnet arrangement, requiring a standard 19V input to the transmitter module. SILVERTEL's modules are high efficiency space optimised solutions. The receiver module provides a low ripple, low noise regulated output. Overload and short-circuit output protection are built-in.

The Ag301 Receiver module provides a 5V regulated output voltage with a current rating of 1A, ideal for supplying the charging circuits of numerous portable devices.

Wireless charging is perfect for hazardous, humid or dirty environments where frequent main-





About Qi and the Wireless Power Consortium

Established in December 2008, the Wireless Power Consortium's mission is to establish Qi as the global standard for wirelessly charging electronic products. The more than 180 members of WPC include industry leaders in mobile phones, consumer electronics, batteries, semi-conductors, components, wireless power technology and infrastructure such as wireless operators, furniture and automotive parts companies. Qi products are available in the United States, Asia Pacific, and Europe.

Samples and Evaluation boards are available from CODICO.

A18

▶ *Andreas Hanausek, +43 1 86305 131
andreas.hanausek@codico.com*

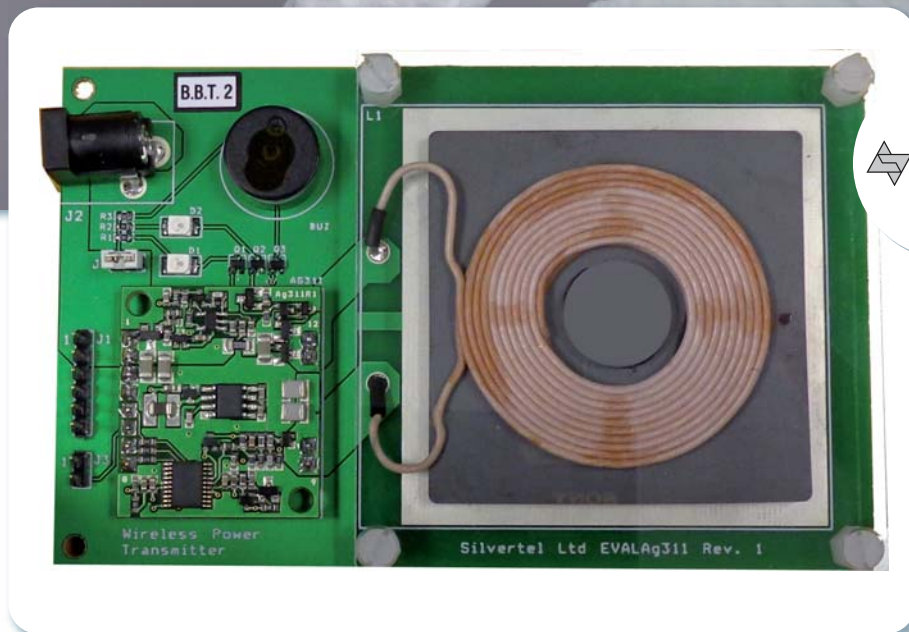

tenance is an issue. Standards based charging also removes the need for device specific power supplies. The module is designed for simple

integration, requiring the addition of just a few extra components. The controller IC is also available for very high volume applications.

ABOUT THE QI STANDARD

The idea behind Qi is simple: all devices with the Qi logo will work with all Qi chargers. That's it. No need for separate chargers, no need for cables, and no need for adapters when travelling. Qi is a global standard – this means that your device can be charged wirelessly wherever you are.

Qi is the proven leader in wireless charging. Qi has unrivalled reach, delivers the best user experience, and is moving the fastest to bring new wireless charging innovations to market.

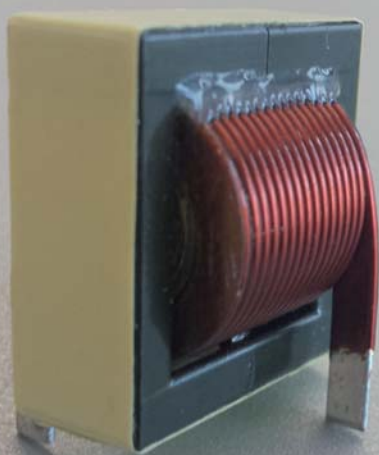

ELYTONE: Full Power ahead!

Helical chokes in compact design formats and with very high rated currents allow for a wide range of inductivity values.

Demanding industrial applications such as welding equipment, or solar or data servers in the computer industry, requires highly efficient power management solutions. In these circuits, helical inductors are used normally as output filtering.

Flat wire technology allows for substantially higher currents than power inductors with conventional round wire formats. Furthermore, the narrow winding structure of the flat wires brings down the ohmic resistance. Helical chokes are available in both THT and SMD formats. The inductance range is from 1.5uH to 260uH, with saturation currents of up to 75A [SMD up to 68A].

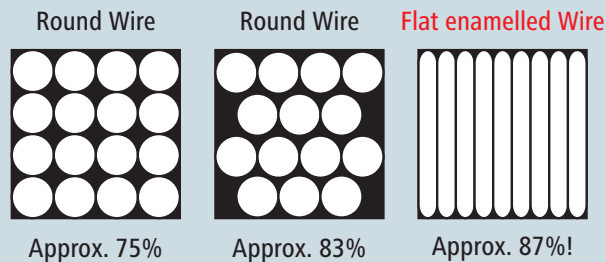

We shall be happy to provide you with some free samples.

P01

▼ *Sven Heinen, +49 2152 204816
sven.heinen@codico.com*



Wireless charging — It's in fashion!

WPC compliant Tx and Rx coils for wireless power charging!

CODICO has a range of different transmitter and receiver coil formats to offer you for wireless energy transfer. These very flat coils meet the WPC Standard and have magnetic shielding. The solution with one to three coils is available with the inductance values 5.7uH, 11.5uH and 24uH, and the transferable power is 5W. Inductive transmission can be found in applications such as mobile phones, automotive systems, shavers, toothbrushes, clocks and watches, electric bicycles, etc.

P02

▼ *Sven Heinen, +49 2152 204816
sven.heinen@codico.com*

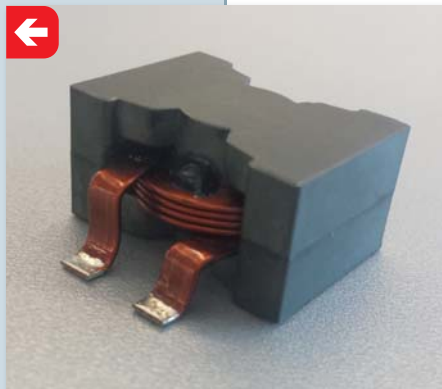

Helical Inductors
up to 75A!



Wireless antenna with 3 coils

ULTRA SMALL POWER INDUCTORS

©gij311 - Fotolia.com

Chip inductors combining four technologies in one unit!

TOKO's DFE Series combines four technologies in one package. High current load values by iron coil cores, low ohmic values by using flat wire technology [minus 40%], terminal connections of a chip inductor, and vibration resistance by encapsulated design.

DFE inductors are ideally suited for DC/DC converter applications with high peak currents. Even at full rated current, the inductance drop is very low.

At the same time, the choke is extremely temperature stable, and exhibits a loss of just 1/6 in comparison with a ferrite inductor.

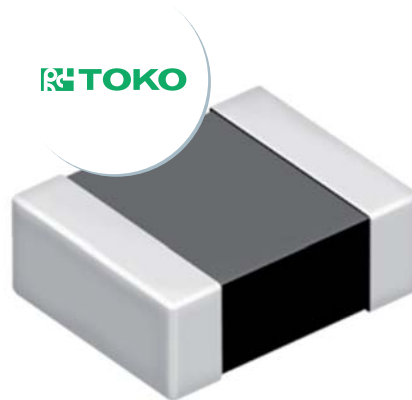

The DFE is available in the design formats 2016, 2520 and 3225.

The inductivity values at rated currents up to 5.9A range from 0.47uH to 10uH. And, of course, the components are RoHS compliant as well as being halogen free.

P03

▼ Sven Heinen, +49 2152 204816
sven.heinen@codico.com

Four Technologies in One Package

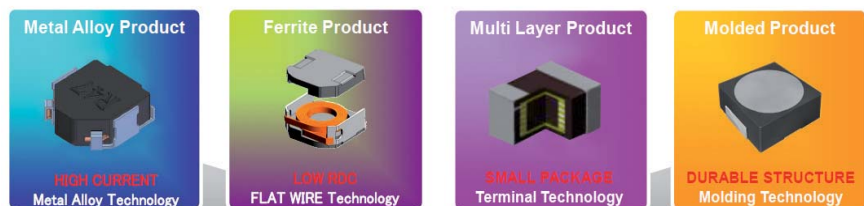

Original Material, Structure & Method

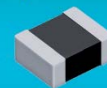

DFE SERIES

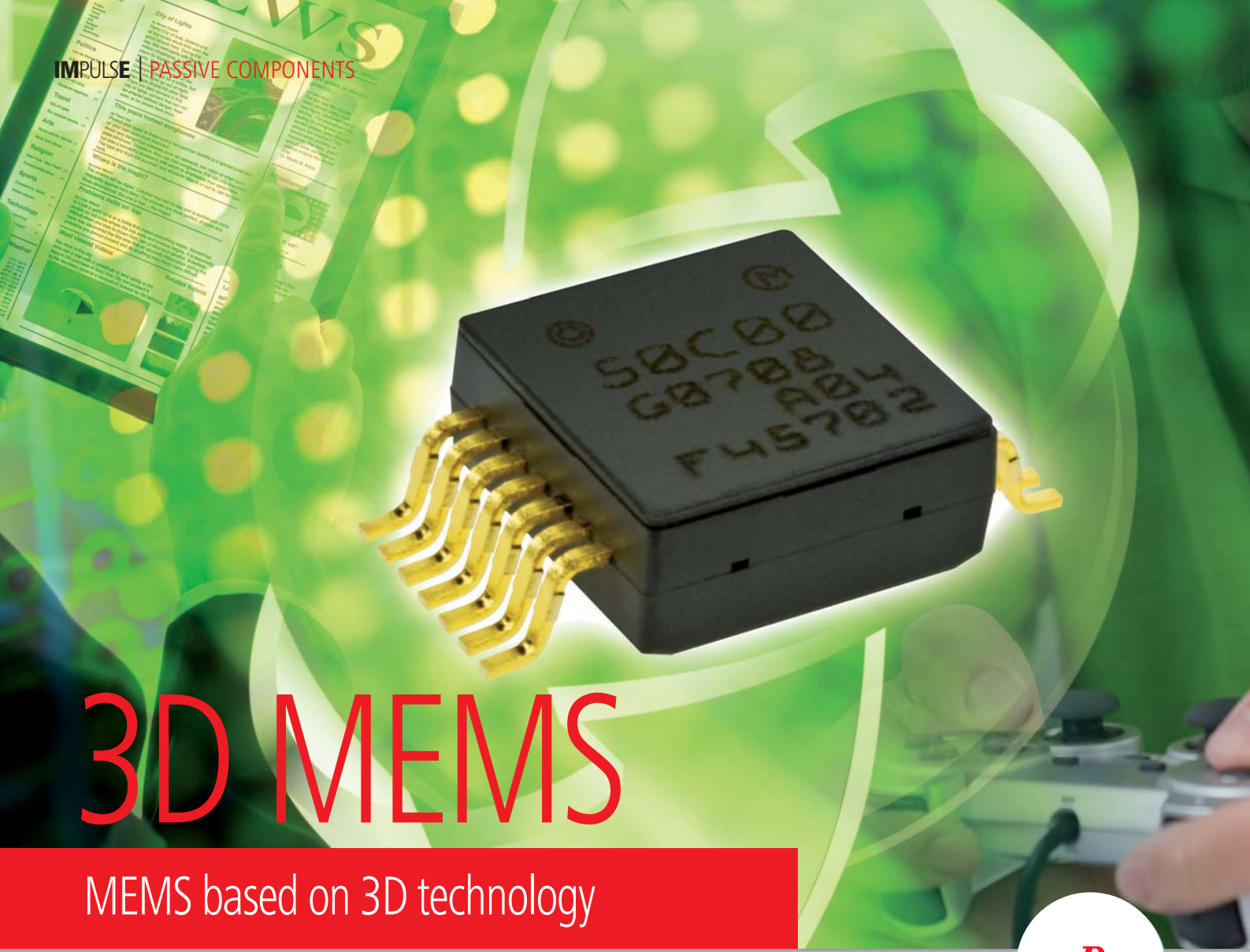

3D MEMS

MEMS based on 3D technology



MEMS gyros and accelerometers are increasingly being incorporated into a broad range of consumer electronic devices, and have now become an essential component of various control systems.

The MEMS gyros and accelerometers MURATA manufacturers use a capacitive detection approach where one or more capacitors change value with an applied mechanical signal. The accelerometer includes one or more (multi-axis) proof masses that sense gravity and acceleration. The force generated on the proof mass is then gauged with a silicone spring converting it to a deflection, to be sensed as a change in the distance between one or more pairs of capacitor plates.

This technology makes it straightforward to achieve various levels of damping by modifying the gas pressure of the cavity where the proof mass is located. Multi-axis elements are generated by shifting the location of the center of gravity of the proof mass relative to the spring suspension, shifting the axis of rotation. The springs are made of single crystal silicone, providing a very stable transfer function with a tem-

perature dependence of gain close to that of the elastic constant of silicone, i.e. less than 1% over 100°C, which is easy to compensate for. The symmetrical structures result in internal self-compensating effects, giving a very stable zero point over temperature and time. The large signal from the sensing element makes the design of the interface electronics easy and enables optimization for very low power, very high resolution or high speed (little filtering). The angular rate sensor, or gyro, utilizes the Co-

riolis effect. A proof mass is brought into angular motion, in this case vibrating angular motion.

An external angular rate perpendicular to this motion will cause a force proportional to both the vibration motion and the angular rate which is perpendicular to both of them. This Coriolis force is detected through synchronized capacitive sensing. Symmetrical structures result in stability and reduced cross sensitivity to linear or angular acceleration.

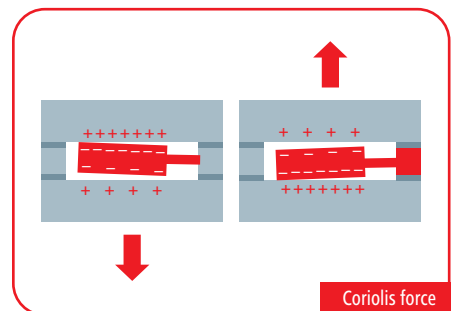
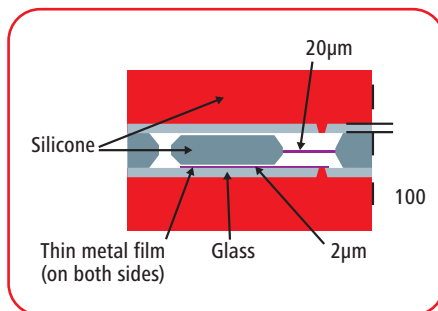

Coriolis force

MURATA offers the following MEMS devices:

Accelerometers are based on the proprietary 3D MEMS technology and they offer a number of excellent product features and benefits for the most demanding applications. The sensing element and the measuring ASIC are assembled in a dual-in-line or dual-in-flat-line plastic package with pins for surface mount and re-flow soldering. They are environmentally protected with silicone-gel resulting in excellent performance and reliability in a humid environment and at temperature cycling. In addition, the robust sensing element design with over damped frequency response enables excellent performance even in harsh and vibrating environments.

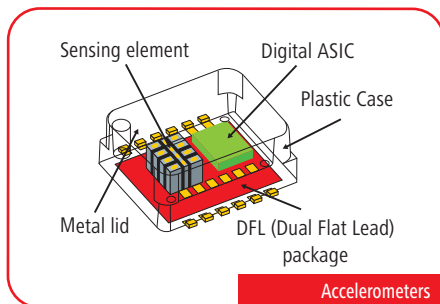

Accelerometers

Inclinometer sensors are an optimum choice for high accuracy leveling and inclination measurement instruments. The highest accuracy is available with SCA103T series that use differential measurement principle to compensate all common mode error and noise effects. The best shock durability of the MEMS market provides trouble-free measurements in moving machines, vehicles, airplanes, construction machines and hand held devices.

Gyroscopes and combined sensors (including gyroscope and accelerometer) are based on the MURATA's proven 3D MEMS technology



Inclinometer sensors



Gyroscopes & combined sensors

and highly integrated electronics. Industrial gyroscopes offer a performance level that typically has been available only for expensive module products. Sensing elements and the measuring circuitry are assembled into a pre-molded plastic dual-in-line (DIL) package, protected with silicone-gel and covered with a stainless steel lid.

P04

► Srecko Drazic, +43 1 86305 104
srecko.drazic@codico.com

MURATA offers wide-ranging experience and in-depth know-how in numerous MEMS applications like:

HEALTHCARE

- > Diagnostic and treatment equipment positioning applications: high precision positioning of equipment such as surgery tables, prostheses and medical imaging equipment
- > Patient monitoring applications: movement and position monitoring



INSTRUMENTS

- > Inclination measurement for electronic level and rotating lasers
- > Inclination measurement for distometers and hypsometers
- > Inclination measurement for scale tilt compensation
- > Tank level and process pressure monitoring systems
- > Inclination measurement for wheel alignment systems
- > Inclination measurement in dynamic environment
- > Avionics
- > Drilling

HEAVY DUTY VEHICLES

- > Accurate navigation for tractor auto steering in agriculture
- > Platform levelling for forestry equipment & construction equipment
- > Inclination measurement for excavator booms and shovels
- > Inclination measurement for transmission control of commercial vehicles
- > IMUs of different vehicle categories
- > Dynamic levelling of platforms

CAPACITOR NEWS



Double-layer capacitors

To provide specific applications with sufficiently high energy or storage capacity for buffering, double-layer capacitors are an ideal solution. They offer many advantages over rechargeable batteries, such as

- > Rapid charging and discharging
- > Long life cycle thanks to the possibility of tens of thousands of charging and discharging cycles
- > Usage over a wide temperature range, and providing stable operation even at low temperatures
- > Very safe / no risk of explosion or ignition
- > Environmentally friendly / no heavy metal content

The CODICO supply range includes two different technologies, which involve two different structure formats. With its EDLCs (Electric Double Layer Capacitors), RUBYCON offers the same basic structure as aluminium electrolyte capacitors, i. e. a wound structure. To serve as electrodes, activated carbon is applied onto the aluminium film.

By contrast, NEC Tokin »SuperCaps« have a cellular structure, with the activated carbon and electrolyte located mixed between the electrodes. The conductive solid which is usually used

in EDLC's is activated carbon, which has many small holes in the surface in order to enlarge it. The space between the two activated carbon electrodes is filled with electrolyte. Charging and discharging takes place by adsorption and desorption of the ions on and from the electrode surfaces.

PRODUCT SPECTRUM RUBYCON

Radial leaded type

Capacitance range: 1F - 190F

Voltage range: 2,5V - 2,7V

Dimensions: 8x16mm - 22x65mm

Screw terminal type

Capacitance range: 850F - 2300F

Voltage range: 2,5V

Dimensions: 36x135mm und 51x135mm

PRODUCT SPECTRUM NEC TOKIN

Can case type

Capacitance range: 0,01F - 5,6F

Voltage range: 3,5V - 12V

Dimensions: 11x5mm - 44,8x60mm

Resin molded type

Capacitance range: 0,01F - 0,22F

Voltage range: 3,5V - 6,5V

Dimensions: 10,5x11,5x5mm - 14x15x9mm

RUBYCON

EDLC Principle

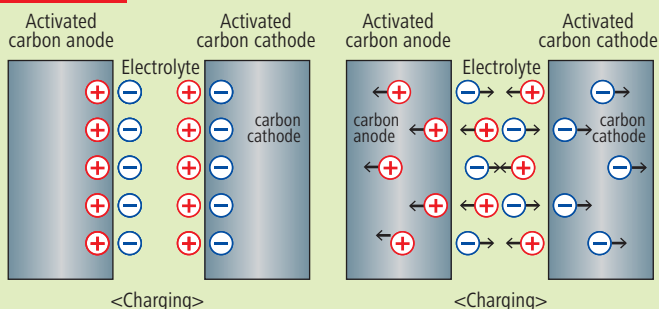

EDLC Structure

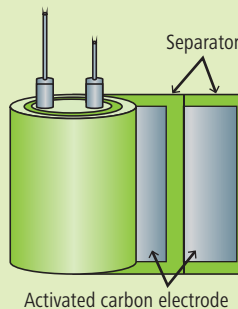

NEC/TOKIN

SuperCap Structure (Cell)

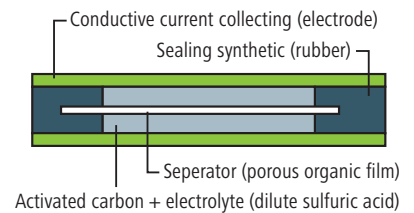

Can Case type

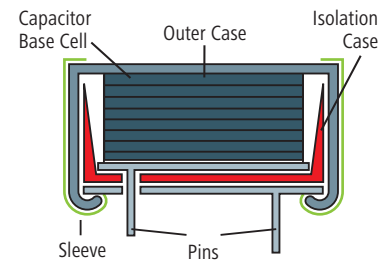

SMD type (FC series)

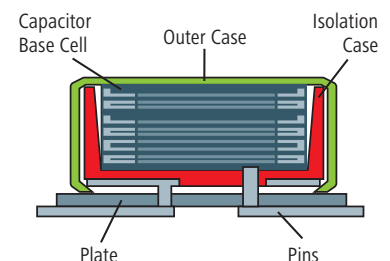

Resin Mold Type (FM series)

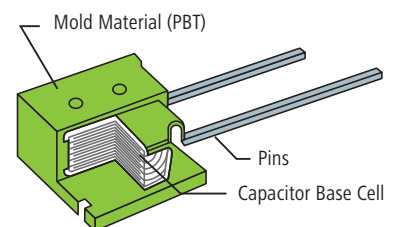

SMD type

Capacitance range: 0,047F - 1F

Voltage range: 3,5V - 5,5V

Dimensions: 10,5x5,5mm - 21x10,5mm

P05

▶ Roland Trimmel, +43 1 86305 144
roland.trimmel@codico.com

Aluminium polymer capacitors

The CODICO supply range provides a broad spectrum of polymer capacitors from a variety of different manufacturers and technologies. This article takes a closer look at the multilayer aluminium-based structure format moulded with a special resin.

A heat-resistant conductive polymer used as the electrolyte is applied onto the aluminium layers. This technology allows for compact designs and low structure heights in particular.

Aluminium polymer capacitors are characterized by the following properties:

- > Extremely low ESR and high ripple current load capability in compact format
- > Full ripple current load capability over the entire temperature range
- > Stable ESR over the entire temperature range
- > No DC-bias effect
- > Better supply reliability and price stability, because of its independence from the tantalum market

STRUCTURE (example: The PC-CON from RUBYCON)

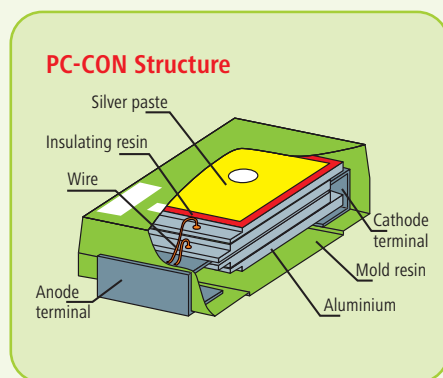

PRODUCT SPECTRUM

PC-CON from RUBYCON
Voltage range: 2V - 10V
Capacitance range: 22uF - 470uF
ESR: Down to 4.5mOhm
Structure height: Down to 1.1mm

ECAS Series from MURATA
Voltage range: 2V - 16V
Capacitance range: 6.8uF - 330uF
ESR: Up to 6mOhm
Structure height: Up to 1.9mm

NEW: SP-caps from PANASONIC
Voltage range: 2V - 25V
Capacitance range: 2.2uF - 560uF
ESR: Up to 3mOhm
Structure height: Up to 1.1mm



P06

▶ Roland Trimmel, +43 1 86305 144
roland.trimmel@codico.com

Loss of capacitance with X2 film capacitors – the answer!

Normal X2 capacitors are designed for rapid self-healing and reliability by having a high proportion of zinc in the metallisation. Under the effect of high air humidity, however, this also has a pronounced tendency to lead to a rapid loss of capacitance, which means that their use is not advisable in capacitive power supplies or voltage dividers.

The loss of capacitance due to corrosion is caused by what is commonly known as THB (temperature, humidity, bias).

The product range from CODICO includes a specially treated X2 capacitor which provides satisfactory long-term stability even under a test with full voltage, 85% relative humidity, and a temperature of 85°C. 1,000 hours are guaranteed under these conditions, which can be translated into >50,000 hours under normal conditions.

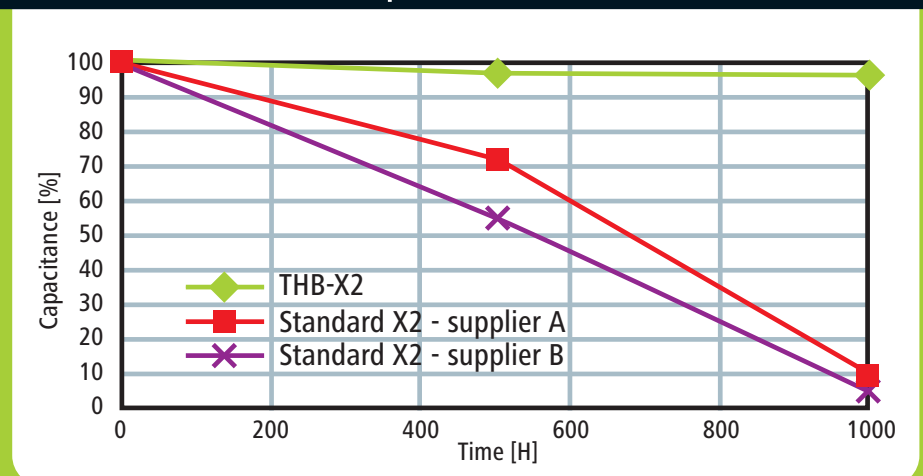

Capacitance range: 47nF - 10uF
Pitch: 15mm - 37.5mm
Dimensions: 6x12x18mm - 32x45x41.5mm

niium metallisation – and CODICO has the right solutions for you there as well. For more details and samples please feel free to contact.

P07

▶ Roland Trimmel, +43 1 86305 144
roland.trimmel@codico.com



GOODSKY

Scott Lee, Michael Blaha, Sven Krumpel, Thomas Hsu, Thomas Jell, Charlie Tseng

NEW

As the technical partner for Design-In, CODICO has reacted to the need to include electromechanical relays into the portfolio. The suppliers selected are focused exclusively on relays, and provide a defined roadmap for products and processes as assurance of future advantages.

1 Signal relays

The range of signal relays from GOODSKY includes ideal products for applications in fax machines, printers, modems, and brown goods.

The application range for these one-pole and two-pole relays covers switching capacities of between 1 and 3 Ampere, with the drives being monostable or bistable depending on the product family, and with SMD variants also available.



©Ilya Glonatsky - Fotolia.com

GOODSKY Electric Co. LTD. is a manufacturer of electromechanical relays for applications in white and brown goods, industry, telecommunications, and office automation, as well as in the automotive industry. A variety of modules and relay accessories are also produced. The company was founded in Taiwan in 1989, and for more than 20 years has been marketing relays worldwide under its own brand name. Manufacture takes place in Taiwan and also in two locations at Shenzhen and Suzhou in China, with an installed capacity of about 150 million relays annually.

Today, GOODSKY is a part of the ECE Group, a company which is quoted on the Taiwan Stock Exchange. The ECE Group is made up of the four Divisions of Electromechanical Components, Stamping and Molding, Goodsky Electric, and the headquarters with the central departments.

Some 60% of the turnover at GOODSKY is generated in China and Asia, and about 30% in EMEA. Principal customers for GOODSKY products include, among others, Philips, Theben, Schneider, Eaton, UTEC/Carrier, and Samsung, and in the automotive sector Nissan, Renault, and Ford. »Customer First« was and is the Credo at GOODSKY.

This means that the four key components, »Customization, Quality, Cost efficiency, and Service« are the focus of the GOODSKY vision and strategy. Every year some 5% of the turnover is invested back into R&D. The relay components come mainly from the various different sections

of the ECE Group, where the synergy effects from the switch and connector sectors are used to optimum advantage. 80 engineers from Taiwan and China are in contact via Intralink software, and work together on product modifications, application consultation, and new products and automation concepts. The very latest design and analysis software such as PRO/E, Solidwork and Ansys, as well as the possibility of rapid prototyping by means of 3D printers all support their work.

To boost these core skills even further, the company has decided to take a major step forwards – the fully automated manufacture of all the focus products. The system concepts for this provide for a closed continuous sequence of all the assembly stages, from the production of the magnet system, the manufacture of the contact system, the adjustment, the capping, printing, and testing. At the end of the line packing also takes place fully automatically. The advantages of this concept are very evident. Further improvement of the quality standard, as well as increasing delivery capacity, particularly important in highly volatile times. The aim is to manufacture 80% of turnover with this concept in 2014.

GOODSKY is certified to ISO 9001 2008, as well as ISO/TS 16949 and ISO 14001. The products are RoHS-compliant and are listed in accordance with CQC, TÜV, UL-CUL and VDE, and very largely fulfil the requirements of IEC 60730-1 and IEC 60335-1. Since 2010 most of the product series have been available with halogen-free materials.

New in the range: Electromechanical relays from SANYOU and GOODSKY



Jormin Zhuo, Mingrong He,
Michael Blaha, Song Chaoyang, Sven Krumpel,
Thomas Jell, October Gong

2 Relays for automotive applications

SANYOU offers an extensive product range of printable and pluggable versions for applications in the automotive sector. These relays are used in central locking systems, wiper control systems, window raisers, parking heating systems, ventilators, and seat modules, to mention just a few possibilities. The products are standardised and compatible with the conventional pin layouts available on the market, with the current range extending between 15 and 70 Ampere.

Dongguan Sanyou Electrical Appliances Co., Ltd. is one of the top 100 Chinese companies in the sector of development, production, and sales of electronic components. The company was founded in 1997, and today produces more than 60 different series with some 10,000 item numbers at the four locations in Dongguan, Mingguang, Ningbo, and Shanghai Wanjia, employing more than 6,000 people. Annual output is around 600 million units per year, produced on 83 fully-automated or partly-automated lines. Relays from SANYOU are used worldwide in the white and brown goods sector, industry, transport, automotive, IT, building technology, energy management, medical equipment, and much more besides. Development, product innovation, and procedures for technology extension have always been the driving forces behind development at SANYOU. More than 50 patents have been registered in the last 10 years alone. One significant competitive advantage lies in the autonomy of product development and the development and construction of automated assembly lines.

SANYOU has made major strides towards boosting knowhow in the fields of relay design, manufacturing technology, and the taking over of production installations thanks to the intensive co-operation with famous name companies from Japan, South Korea, and Great Britain. Massive efforts and investments have been made in the sector of development and manufacture of precision tools, parts manufacture of stamped and molded components, and assembly, to achieve a truly international position.

SANYOU is certified in accordance with ISO 9001 2008 and ISO/TS 16949, as well as ISO 14001. The products are RoHS-compliant and are listed in accordance with CQC, UL-CUL, with many series also being listed in accordance with VDE and TÜV.

The SANYOU laboratory is VDE and UL certified, which substantially reduces the run time for projects. Cutting edge technology in AC and DC test stations for measuring the electrical and mechanical performance under different loads, temperatures, and air humidity, as well as modern analysis resources such as spectrometers, high speed cameras, vibration plates, and glow-wire measuring devices all support the development work.

The main goals at SANYOU include further automation, a stronger presence in the automotive sector, a further increase in capacity and ongoing quality improvement. The aim here is to attain NG rates at the customer of <math><5\text{ppm}</math>. And to achieve this, SANYOU follows its corporate code very consistently:

- > Quality first
- > More action result orientation
- > Innovation
- > Integrity

With this philosophy SANYOU has, within a very short space of time, succeeded in becoming one of the largest relay manufacturers in the world, and today supplies global customers such as GE, Whirlpool, Schneider, UTEC Carrier, LG, and Samsung, to name just a few.





3 Very latest relay and accessory products



4 Latching relays from SANYOU



5 CODICO portfolio

With the relays from the series LR, EMI/EZ, and RE, and the extensive range of accessories consisting of holders, retaining bars, labelling boards, and plug-in modules, GOODSKY covers the needs of a modern interface product range in the switch cabinet. Three installation widths are available, of 6.2mm, 15.7mm and 27.2mm for 1, 2 and 4-pole relays from 5 to 16 Ampere.

At the production facility in Shanghai SANYOU produces polarized bistable relays with single-coil or two-coil drive systems from 25 to 200A. These relays are used mainly in electricity energy meters. The connections are, as a rule, adjusted to the application. If required, we shall be happy to specify the right relay for you and, if necessary, help implement the customer-specific adaptations with the manufacturers.

The focus at CODICO in the first instance is on applications in industry, building technology, white goods, and the energy management sector. The following overview presents the range of products in the main series. The scope of applications extends to switching currents of between 3 to 30 Ampere, with one-pole and two-pole versions and coil power with actuation values of between 170mW and 1.6Watt.

Series	JE	SRB	SJ-M(5A)	SJE	SRDI	SRG	LR	EMR	EZ/EZI/EMI-1	EMI-2	EML	SFK	SLA/SLC
Highlights	low profile 10.5mm in acc. with IEC 60730-1	5A switching capability small size for high density PCB mounting	sensitive coil 200mW 10A version and CO version on request	5A/10A switching capability small size for high density PCB mounting	12A switching capability in acc. with IEC 60335-1	17A switching capability in acc. with IEC 60335-1	5mm slim upright and flat version/socket use possible 170mW coil power	8mm safety distance in acc. with IEC 60335-1 and IEC 60730-1	DC and AC coils in acc. with IEC 60335-1 and IEC 60730-1	DC and AC coils in acc. with IEC 60335-1 and IEC 60730-1	W pre-make contact Tungsten Load: 3000VA/230VAC	25A switching capability "H" version with contact gap >1.5mm	30A switching capability "H" & "S" version with contact gap >1.5mm
Contact form	1 NO/1CO	1 NO	1 NO	1 NO/1CO	1NO/1NC/1CO	1NO/1NC/1CO	1 NO/1CO	1NO/1NC/1CO	1NO/1NC/1CO	2NO/2NC/2CO	1NO	1NO	1NO/1NC/1CO
Rated current	NO: 8A CO: 5A	5A	3A (L coil) 5A (D coil)	NO: 10A NC: 5A	NO: 10A NC: 7A	NO: 17A NC: 10A	8A	8A	16A/12A	8A	16A	25A	30A/15A/ 20A/10A
Coil voltage	3 to 48VDC	5 to 24VDC	3 to 24VDC	3 to 48VDC	3 to 60VDC	5 to 48VDC	3 to 60VDC	3 to 60VDC	3 to 110VDC/ 24 to 230VAC	4 to 110VDC/ 24 to 230VAC	3 to 60VDC	5 to 24VDC	5 to 110VDC
Coil power	200mW	200mW 360mW	200mW(L) 450mW(D)	200mW 400mW 450mW	360mW	360mW	170mW	220mW	400mW	400mW	400mW	900mW H: 1.4W	900mW H: 1.1W S: 1.6W
Ambient temp.	+85°C	+85°C	+105°C	+105°C	+105°C	+105°C	+85°C	+85°C	+85°C	+85°C	+85°C	+85°C	+105°C
Terminal type	THT	THT	THT	THT	THT	THT	THT	THT	THT	THT	THT	THT/QC	THT/QC
Mounting	PCB	PCB	PCB	PCB	PCB	PCB	PCB	PCB	PCB	PCB	PCB	PCB	PCB
Dimensions LxWxH (mm)	20.0 x 10.0 x 10.5	20.5 x 7.0 x 15.1	18.4 x 10.2 x 15.5	20.6 x 10.2 x 15.5	19.6 x 15.4 x 15.5	21.0 x 16.0 x 21.6	28.0 x 5.0 x 15.0	30.0 x 10.0 x 15.0	29.0 x 12.6 x 15.8	29.0 x 12.6 x 15.8	29.0 x 12.6 x 15.7	30.1 x 15.7 x 23.3	31.5 x 27.4 x 19.8



P08

Michael Blaha, +43 1 86 305 105, michael.blaha@codico.com

ACCURACY & STABILITY: HIGH VOLTAGE DIVIDERS

Thick-film planar technology enables a new generation of highly stable, highly precise and highly optimized voltage dividers.

TT electronics is further extending its range of innovative solutions for challenging applications, with the introduction of three families of thick-film precision resistive dividers targeting high-voltage measurement circuits. The new devices are being launched in response to growing demand in the Energy, Medical, Industrial and Instrumentation markets.

The demand for this class of device is growing as vertical sectors expand. Applications like portable defibrillators, high voltage PSUs and vehicle mounted instrumentation require components that offer tight tolerances, class-leading temperature coefficients (TCRs), long life stability and extremely high ohmic values, in packages that deliver the optimum space, weight and cost combination.

The new families all maximise TT electronics' expertise in developing solutions for measuring high voltages, comprising the High Voltage Divider (HVD), High Voltage Planar (HVP) and Robust High Voltage Divider (RHVD) families.

»We have used our expertise in thick-film technology to create three families of resistive dividers that perfectly fit the needs of growing and emerging markets,« said Stephen Oxley, senior applications engineer. »The increased demand

for specialty resistors is a direct consequence of emerging applications like portable defibrillators and scanners, insulation testers and high voltage meters that absolutely must have the right solution.«

The HVD family offers voltage ratings up to 30kV in a SIL package, with ohmic values up to

5G Ω ; the HVP family reaches 10G Ω and 20kV (also in a SIL format) while the RHVD family adopts a robust DIL package making it suitable for applications that experience high vibration, such as vehicle mounted instrumentation, in a range that offers up to 1G Ω and 15kV. All three families are non-inductive and achieve 0.25% accuracy, with a 25ppm/ $^{\circ}\text{C}$ TCR.

P09

► Srečko Drazic, +43 1 86305 104
srecko.drazic@codico.com

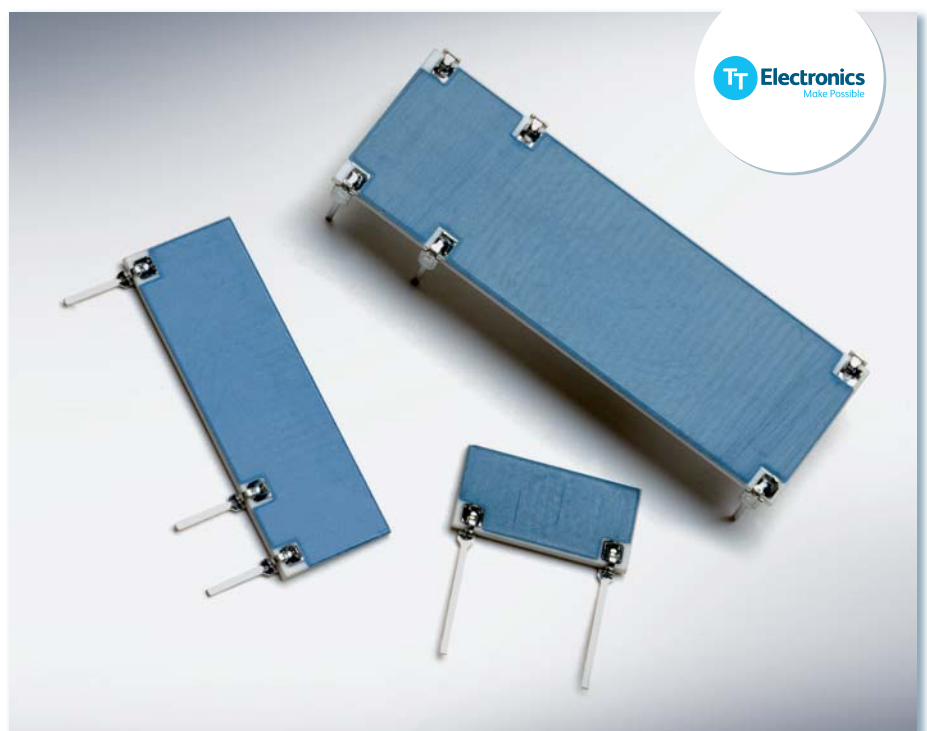

GREEN AND ROBUST



FCI launches a robust and green two-piece High Power Card Edge® Board-to-Board Connector!



FCI, a leading supplier of connectors and interconnect systems, recently boosted its power solution offerings with the introduction of the High Power Card Edge® (HPCE) Board-to-Board (BTB) connectors.

Added to FCI's popular HPCE® Connector (one-piece) and HPCE® Cable (both one-piece and two-piece), this new header and receptacle solution provides more options for customers looking for high current density board-to-board connectivity.

Specifically designed for applications requiring a high current density and low power loss, this two-piece solution delivers up to 200Amps/linear inch, a low contact resistance of just 0.6mΩ per contact, within a compact design of just 7.5mm in height. The innovative power contacts and housings are made for demanding

AC and DC power distribution applications, and are ideal for next generation 1U/2U servers, switches, storage enclosures, telecommunication equipment, industrial PCs, controls and instrumentation equipment.

»Following the success of our single-piece HPCE® solution, we developed a two-piece connector solution to serve a wider range of applications,« says Michael Blanchfield, Portfolio Director for Power Solutions at FCI. **»One of the key characteristics of the new connector is the ability to reduce contact resistance and minimize energy loss. We are confident the HPCE Board-to-Board connectors will meet many of our customers' demands for increased reliability and energy efficiency in miniaturized power connectors.«**

The HPCE® BTB connectors are produced in a wide variety of configurations to serve a

variety of applications. The integrated guide features enable »blind-mating« which facilitates easy connectivity and precise alignment.

The connector also features a highly ventilated housing design which enhances heat dissipation. This is a crucial feature in server and data storage applications, as it helps avert overheating issues, and increases the reliability of the end equipment.

The HPCE® BTB connector offers unparalleled power and signal density in a miniaturized board-to-board platform. Samples are available for immediate release. For more information contact us.

501

► Gerhard Strobl, +43 1 86305 137
gerhard.strobl@codico.com

MULTIFUNCTIONAL LED CONNECTION SYSTEM

HIROSE has introduced the DF64 series connector system to meet the requirement for small connectors for the LED lighting market and power supply applications.



The multifunctional connector is applicable for board-to-wire power supply connections and board-to-board »bridge« connections. Only one type of receptacle is needed, irrespective of whether the cable plug or board mount plug is used, allowing a reduction in the number of components needed.

The connection system can be applied with 5A (Amps) maximum current rating when using AWG18 cable size. The creepage distance is a minimum of 3.2mm between the contacts allowing a 350V voltage rating to be applied.

The board-to-wire connector utilises a unique stress free, side locking structure that is a user friendly, innovative, locking mechanism that allows a higher cable pull retention force. The lock provides a consistent and positive tactile click, this ensures the connector is fully engaged

guaranteeing complete electrical and mechanical connection. In the mated condition, the contacts touch together in two different areas providing high contact reliability.

The board-to-board »bridge« connector has a floating structure to allow a movement toleran-



Key Features

- > Contact positions: 2 & 3
- > Current rating: 5A (max)
- > Pitch: 4.5mm
- > Voltage rating: AC/DC 350V
- > Cable size: AWG18 - 22
- > Temperature rating: -55°C - +105°C
- > Halogen free product

ce of ± 0.5 mm for the X axis direction, and 2mm (max) for the Y axis direction allowing greater flexibility during the installation process.

Suitable applications are LED lighting, automotive headlamps, medical devices, FA controllers and other power supplies. For more information please contact us.

S02

► Gerhard Strobl, +43 1 86305 137
gerhard.strobl@codico.com



FULLY WATERPROOF

High Current Capacity, IP68 Waterproof, Circular Connector



Key Features

- > Contact positions: 3 & 5
- > Current rating: 20A
- > Voltage rating: AC/DC 400V (3 Pos.) AC 600V/DC 400V (5 Pos.)
- > Lightning surge protection: 15kV
- > Waterproof rating: IP68
- > Locking mechanism: Bayonet
- > Compliance: 2000 hours sunshine weather test. 1500 hours salt spray

HIROSE has introduced the HR41 range to meet the requirement for high powered connectors offering advanced reliability in outdoor harsh environments.

The connector range consists of bayonet locking, cable mount plugs and panel mount receptacles that have the capacity to handle up to 20A (Amps).

The HR41 is optimised for easy field assembly with a standard market commodity crimp tool. A visual and tactile raised mating indicator is present on the plug and receptacle to aid the

mating operation in dark conditions. The cable can be clamped and the waterproof gasket sealed in one simultaneous step without additional tooling. The anti loosening mechanism ensures that the tightening ring securing the cable will not come loose during operation.

The innovative connector design incorporates a sequential contact structure. The contacts are arranged in sequence to ensure the ground contact is connected before the power contacts during the mating process to ensure safety. In addition, housing walls protect the contacts and ensures a long creepage distance.

The light weight housing is robust and resistant against harsh environmental conditions, such as sunshine (2000 hr tested), salt spray (1500 hr tested) and water intrusion (IP68 rated). In addition, HR41 is resistant against 15kV lightning surges due to the special housing wall structure.

A contact removal tool is available to quickly remove the contact from the housing.

Ideal applications are LED lighting, tunnel lighting, construction lighting, fishing lighting, offshore lighting, robots, electronic toll systems and other industrial applications. For more information please contact us.



S03

▶ Gerhard Strobl, +43 1 86305 137
gerhard.strobl@codico.com

Suitable for automated assembly,
cuts post-processing, facilitates easy inspection

SHIELD CANS

HARWIN, the leading hi-rel connector and SMT board hardware manufacturer, has expanded its popular EZ-BoardWare portfolio of surface mount PCB hardware components with the introduction of EZ RFI Shield Cans which, when used with the company's EZ-BoardWare RFI Shield Can Clips, provide excellent RFI and EMI protection to sensitive circuitry at PCB level.

EZ-BoardWare RFI Shield Cans from HARWIN deliver excellent, cost-effective RFI/EMI screening

Because the cans are mounted by simply pushing them into the surface mount clips, installation costs are minimised since there is no secondary processing required. More, cans can be easily removed for inspection/repair/rework with no fear of damage to the PCB. The clips ensure secure can retention, resistant to shock and vibration.

New EZ RFI Shield Cans feature a mechanically-robust, simple five sided box design that saves cost when compared to fence and cover styles. Cans are made of Nickel Silver to ensure good screening and are available in a range of sizes to suit popular applications.

Comments HARWIN Product Manager, Paul Gilham: »These cans provide a cost-effective method of delivering screening, since they enable manufacturers to optimise automated processes and eliminate expensive hand assembly processing. Beneficial for many markets, EZ RFI Shield Cans will be used in applications including radio systems, wireless equipment and consumer electronics, where low cost, effective can retention needs to be combined with good shielding performance.«

About HARWIN

HARWIN is a manufacturer of standard interconnect components with an enviable reputation for high quality and exceptional customer service. HARWIN has been successfully manufacturing electronic components for more than 50 years. HARWIN's sales and service extend worldwide via offices and manufacturing facilities in the UK, USA, Germany, Singapore and Taiwan and a world-wide distribution network.

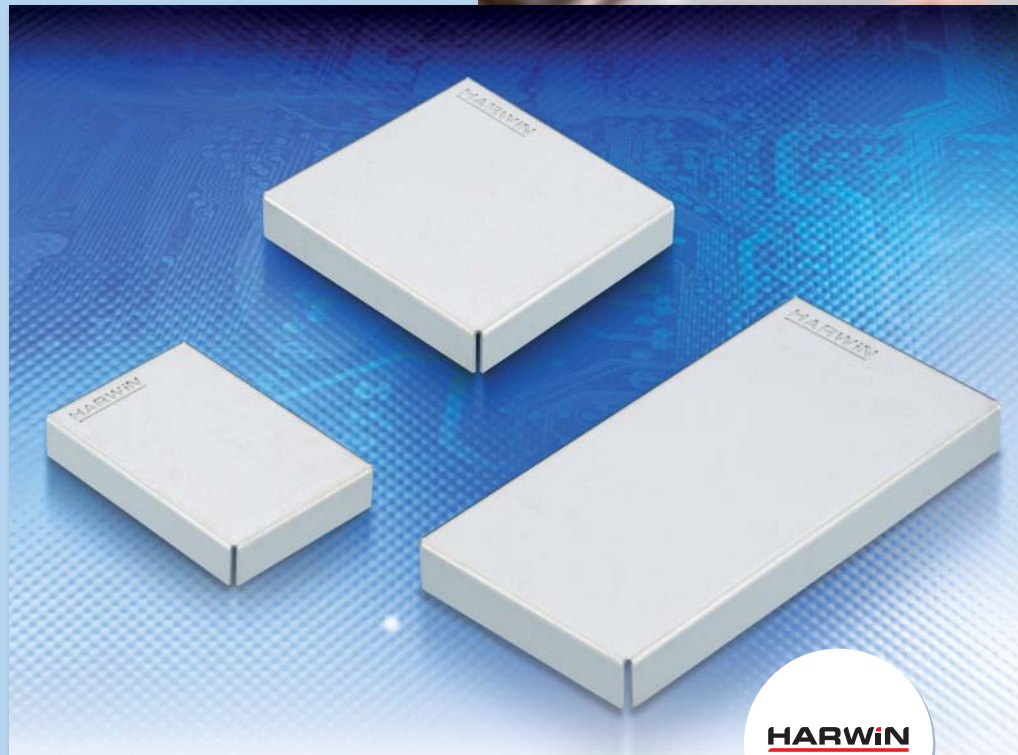

Products include: High Reliability devices; RFI and PCB Hardware; and an extensive range of industry standard interconnection solutions. The company operates a continuous product development program.

For more details contact:

S04

▶ Gerhard Strobl, +43 1 86305 137
gerhard.strobl@codico.com

LED TERMINAL BLOCKS

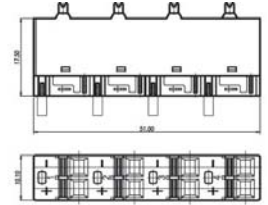
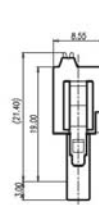
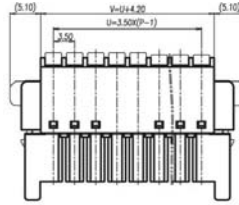

PCB mount design

- > Rated voltage: 300V
- > Rated current: 15A
- > Pitch: 5.08mm
- > Cross-section: AWG12-24
- > Number of pins: 2x4
- > Printing for wiring recognition possible



Pluggable design

- > Rated voltage: 300V
- > Rated current: 8A
- > Pitch: 3.50mm
- > Cross-section: AWG16-28
- > Number of pins: 2-24
- > Printing for wiring recognition possible
- > Optional header: 90° and 180°
- > PBT or PA4T
- > Mounting fastener by screw & clip

LED embedded Terminal Blocks offer 2 different designs:

PCB mount design consists of a spring type PCB terminal block available in 5.08mm pitch. Terminals and solid wires can be inserted into the block directly.

Pluggable design consists of a PCB header (straight or right angle) and a spring plug. It is available in 3.50mm pitch.

Both spring designs enable easy and simple mounting and insertion. For wiring recognition please ask for additional printings.

The pluggable design offers an additional feature: it is fitted with screws and clips for mounting fastening and to be compliant with anti-vibration requirement.

Both LED embedded designs combine the proven quality of DINKLE's Terminal Blocks fitted with LEDs.

They provide clear visual indication, convenience and space saving. So they are applicable to industrial PLC, expandable I/O module and control relevant products.

S05

Barbara Maier, +43 1 86305 134
barbara.maier@codico.com

FPS009-2903-0 for automotive applications:

A HIGHLIGHT AMONG CARD READERS



The FPS009-2903-0 card reader is a top-mount variant with push/push mechanism. This means that the card is pushed in manually, engaged with a soft-lock mechanism, and, when the card is pushed again, it is ejected on a defined path.

Two card brakes prevent the card from being flicked out, and ensure that it can be removed easily and conveniently. A card presence switch registers when the card has arrived in its end position, and switches over to carry out the reading and writing processes. Thanks to the closed metal cover, together with the four grounding tabs, a particularly good EMC performance is achieved.

Particularly worth noting is the special contact design of the card reader:

The two-point contact arrangement evens out vibrations and shock moments, and guarantees full functional performance.

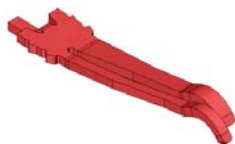

Keeping it short:

At a temperature range from -30° to +85°C, the FPS009-2903-0 card reader features high contact reliability and easy convenient operation.

Thanks to its robust overall design and the wide range of features, the card reader is also well-suited for the automotive sector.

In addition to these low-size components, YAMAICHI Electronics also provides many other card insert connectors for the most widely-used flash and SIM card types, with a range of different form factors:

We would be happy to help you choose the card reader that's right for you!

S06

▶ Barbara Maier, +43 1 86305 134
barbara.maier@codico.com

Series FPS
SD/MMC-Cards



Series PJS
MicroSD-Cards



Series FUS
microSIM-Cards



Series FMS
SIM-Cards



Series CF
Compact Flash-Cards



Series CNS/CNT
PCMCIA-Cards



Series FRS
Combo Card Readers



CONNECTIONS THAT REALLY LIGHT UP LEDs!

A number of manufacturers have developed connections in response to the requirements and needs of the market, which, among other things, are well-suited for use in LED lighting systems. The range and variety of the products in this context genuinely know no bounds: Starting from the simple but effective CIL1 and CIL3 series from CviLux, to the RotaConnect system from FCI for angled PCBs, and on to the most widely differing variants from HIROSE, which among other things exhibit some very attractive features (such as tolerance in x, y and z direction, as well as engagement with an audible click).



CIL1



CIL3

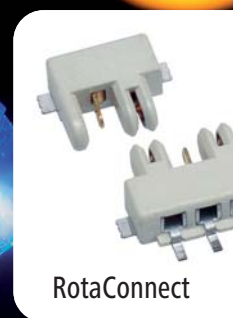

RotaConnect



DF59



DF59S & DF59SN

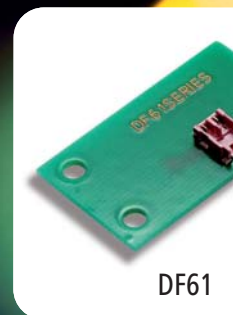

DF61

The different connecting systems with their different properties have a solution to suit almost

Manufacturer	Series	Connection	PCB	Number of pins	Pitch (mm)	Height (mm)	Wire size	Rated Voltage & Current
CviLux Corporation	CIL1	Board-to-Board	horizontal	2	3.50	3.00	-	3A, 250V AC (r.m.s.)
	CIL3	Board-to-Board	horizontal	2	3.00	2.75	-	1A, 150V AC (r.m.s.)
FCI Connect	RotaConnect	Board-to-Board	angled +90° until -60°	2 & 4 (up to 14P on inquiry)	3.00	3.70	-	5A, 125V
Hirose Electric Europe B.V.	DF57H	Wire-to-Board	-	2 - 6	1.20 2.40 (w/o Center Pin = 2P)	1.40 or 1.60	AWG26-34	2.50A, 50V or 100V (for 2.40mm) AC/DC
	DF59	Board-to-Board	-	2 - 4	2.00 4.00 (w/o Center Pin = 2P)	2.50	-	3A, 230V or 350V (for 4.00mm) AC/DC
		Wire-to-Board	horizontal	2 - 4	2.00 4.00 (w/o Center Pin = 2P)	2.50	AWG22	3A, 230V or 350V (for 4.00mm) AC/DC
	DF59S/SN	Board-to-Board	horizontal	1		1.18 or 1.20	-	3A, 350V AC/DC
	DF61	Wire-to-Board	-	2	2.20	2.20	AWG22-28	5A, 350V AC/DC
	DF64	Board-to-Board	horizontal	2 - 3	4.50	4.70	-	5A, 350V AC/DC
		Wire-to-Board	-	2 - 3	4.50	4.70	AWG18-22	5A, 350V AC/DC



S07

Barbara Maier, +43 1 86305 134
barbara.maier@codico.com



every conceivable application:

Special features
<ul style="list-style-type: none"> > 1pc system > Halogene free > With locking
<ul style="list-style-type: none"> > Halogene free > With locking
1pc system
Swing-lock-Structure
Floating Structure in 3 axial directions: 0,50mm in x, y and z axis
Swing-lock-Structure
<ul style="list-style-type: none"> > Halogene free > 1 Recepta+J3+J3cle for 2 Header/Plugs • DF59S slim line plug • DF59SN ultra slim line plug > Floating Structure in 3 axial directions: • 0,50mm in x, y and • 0,20mm in z axis
<ul style="list-style-type: none"> > Swing-lock-Structure > available in 3 colours (red, yellow, beige)
<ul style="list-style-type: none"> > 2 Point contact structure > Floating Structure in 2 axial directions: • 0,50mm in x and 2mm in y axis
Clear tactile click

Y-Circ® P

New Circular Connector
with Push-Pull Locking

YCIRC
S E R I E S



Y-Circ

YAMAICHI
ELECTRONICS

- > IP50
- > Push-pull locking mechanism
- > 360° EMI shielding
- > Space saving design
- > Keying system
- > Housings are available in 3 sizes
- > 2-26 contacts
- > 5000 mating cycles
- > Can be connected with existing series on the market

YAMAICHI Electronics introduces a new series of circular connectors »made in Germany« with a push-pull locking mechanism. It offers cost advantages due to material reduction and thus space saving design. Customers benefit from excellent support and service.

As an experienced connector manufacturer, YAMAICHI Electronics Deutschland GmbH has developed a new circular connector series: Y-Circ® P. The series name stands for Circular Connector Push-Pull. To permit fast, flexible production, the connector series is produced by Yamaichi Electronics in Germany. This location has been active in the area of connector manufacturing and cable assembling for years. So in addition to connectors, customer-specific cable assemblies can also be offered.

The push-pull locking mechanism permits the simple insertion and unlocking of the connector by pulling on the housing. High-quality contacts permit at least 5,000 plug cycles. The Y-Circ® P series can be connected to other existing series on the market, but it has clear advantages. For example, the connector is significantly shorter than the competing products, saving space.

The design of the shield contacts was also optimized. That greatly simplifies the assembly of the connector, reducing the time and expense for assembly.

YAMAICHI Electronics Deutschland GmbH starts with the B series of the connector. It has a protection rating of IP50 and can be ordered in a number of combinations. Initially, three different diameters will be available, each of which can be equipped with a different number of contacts. The chrome-plated metal housing is high in quality and tough, so the connector is also suitable for use on visually demanding devices. The machined contacts mean that both secure data transmission and high currents are no problem.

YAMAICHI's product manager for the Y-Circ® P product family explains: »The Y-Circ® P allows YAMAICHI to open up new market segments and customers for whom other products from our company will also be interesting. We can also offer an interesting alternative made in Germany for customers already using a connector with a push-pull locking mechanism.«

S08

Barbara Maier, +43 1 86305 134
barbara.maier@codico.com

RFK 2

The sovereign solution for Pitch 2.5 connections



The RFK 2 connector system from the well-known German manufacturer STOCKO Contact is made up of socket connectors and pin connectors for a 2.50mm pitch spacing. The following variants are available:



Socket connectors

- > With crimp connection as an indirect connector, cross-section range from 0.12-0.50mm²
- > With insulation displacement connector (IDC) as direct and indirect connector, cross-section range from 0.14-0.25mm²
- > Both flat strips as well as individual leads can be attached

Here are the technical details, at a glance:

- > Pitch dimension: 2.50mm
- > Number of poles: Up to 20
- > Connection type for socket connectors: Insulation displacement and crimp technology
- > Connection type for pin connectors: Soldering technique
- > Temperature range: -40°C bis + 115°C
- > Approvals: UL certified
- > Insulating body: PC, glow-wire resistant, GWT 750°C in accordance with IEC 60335-1

		MKF 13260	MKF 13470	MKH 5130
	Federleisten ▷ Socket connectors			
	▽ Stiftwannen Pin connectors			
Page	▽ Series	8	9-11	12
13	MKS 1650	●		●
14	MKS 1750	●		●
15	MKS 2650	●		●
17	MKS 2670	●		●
16	MKS 2750	●		●
18	MKS 2770	●		●
19	MKS 1850	●		●
20	MKS 1950	●		●
21	MKS 2620	●		●
22	MKS 2850	●		●
23	MKS 2950	●		●
24	MKS 11850	●		●
25	MKS 12850	●		●
	Platinenrand geschlitzt PCB edge slot position		●	

Pin connectors

- > With and without locking latch, in vertical and horizontal design format
- > The double pin housing can be used as a flying coupling

Highlights

And, of course, we can also provide the tools needed, as well as the appropriate crimp contacts. And as an added highlight with the RFK 2 series, despite being manufactured in Germany, from a minimum quantity of about 10,000 units the price is very economical.

509

Barbara Maier
+43 1 86305 134

barbara.maier@codico.com

DISPLAY YOUR VISION

RECORD NUMBER OF VISITORS: CODICO at the embedded world 2014

The embedded world Exhibition & Conference 2014 opened its doors from 24.-26.2014 in Nuremberg, and achieved records for numbers of exhibitors and visitors. 26,688 trade visitors from all over the world were welcomed, along with 856 exhibitors, which equates to a rise of 18% in visitors alone. This means that the twelfth embedded world is most clearly one of the biggest events in its history. It sets out to be the most important and largest sector exhibition involving the high-tech sector of embedded systems.

The CODICO booth welcomed a very large number of visitors, giving them the opportunity to attend interesting product presentations and efficiently organized technical discussions. CODICO staff members were on hand to provide all their know-how, and as a change there was a handmade type of racetrack from Vienna's Museum Quarter. The two-level racetrack combines art, fun, and technology, all in one, with two players competing to achieve the best lap times.

The photos here show the wide range of impressions at the CODICO Stand in hall 4, booth 268.

D03
▼ Birgit Punzet, +43 1 86305 209
birgit.punzet@codico.com

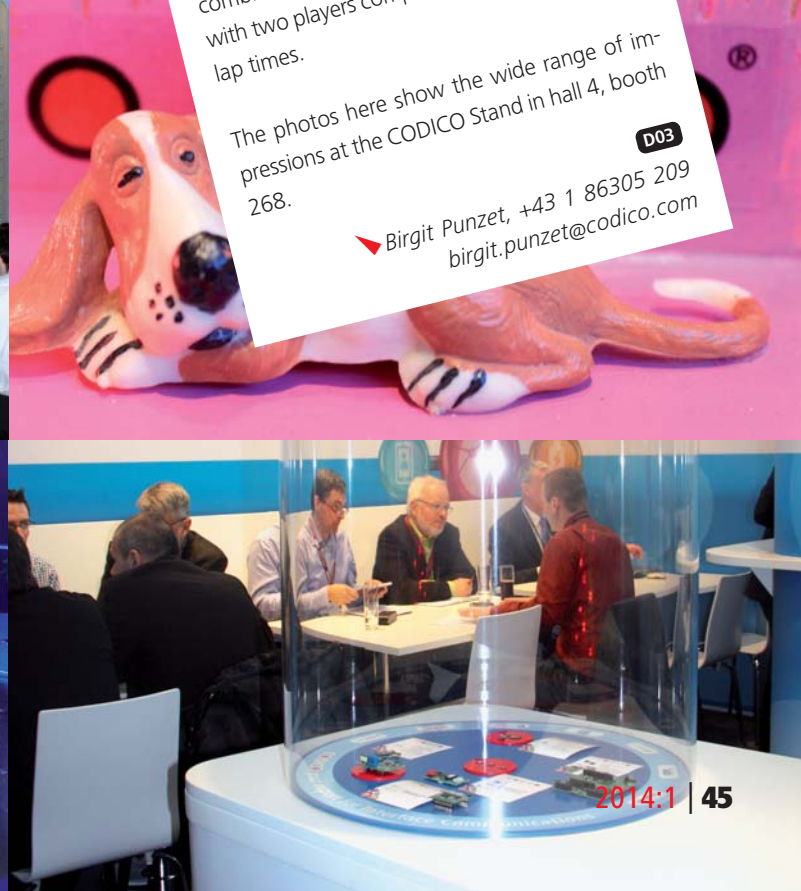

Claus NIELSEN

Now it's my turn for a small personal presentation. My name is Claus Nielsen. I joined CODICO in February 2011. I work as a Sales Manager in the Active components department and I cover the Nordics (Denmark, Sweden, Norway and Finland) and the Baltics.

Before I joined CODICO, I have been working for different distributors with focus on active components. I started my career in distribution at a Norwegian company called Jacob Hatteland. Jacob Hatteland was a privately owned company, so when I started talking to CODICO one of the things I looked for was the atmosphere I believe you only find in a privately owned company. And I found what I was looking for: a feeling of friendliness and a feeling of community. I'm happy to work at CODICO!

I'm 45 years old and I live in the center of Jutland in a city named Silkeborg. I have two wonderful kids, a 16 years old daughter and a 12 years old son, being a single dad they make sure you are on your toes all the time... I was born in Roskilde. Roskilde is a city just outside of Copenhagen. With the age of 4 my family moved from Roskilde to, the small island in the middle of Denmark, called Fyn.

In my spare time I love to travel around Europe seeing as many countries and cities as possible. I find it very interesting to study different cultures, and I also like checking out a country's historical monuments and its architecture. I have visited France a lot, as I have some family living there. They live 50 kilometers east of Marseille. So the French Riviera is almost my 3rd home, after Silkeborg and Perchtoldsdorf of course.

I have a few hobbies. Badminton, cycling and motocross are some of them. The area I live in is very good for mountain biking, as we have the most forest and the highest mountains in Denmark. Working for CODICO and driving motocross I had no other choice than to own a KTM SX-F 250. As KTM is an Austrian brand. See you all soon.

D04

▼ Claus Nielsen, +45 7027 2460
claus.nielsen@codico.com

OUR STRONG CODICO TEAM

Alexander GRABNER



Alexander Grabner

Dear Readers! My name is Alexander Grabner, and since April 2011 I've been a part of the power behind the stock logistics team. Thanks to the fact that I really like sorting and ordering things in my life, I really enjoy the work. The different sectors involved also make my work constantly varied, and, as well as that, we're a great team and support each other all the time. To balance this out in my private life I have my friends and family.

Hobbies, hmm ??? I actually have only one major hobby, and that's multimedia technology, and everything that goes with it. As well as TV and computer, it now also includes smartphones and tablets. I always try to be at the cutting edge, and the most important thing is to understand it all.

For my free time I have discovered the pleasures of sport. As well as power sports and »slinging«, I'm keen on walking and climbing. There's nothing I like more than being on holiday with my closest friends, and just having a good time in some lonesome mountain hut. Nature and the fresh air give me the strength I need for my everyday work. Apart from that, I also like making short city breaks, provided I don't have to sit in an aircraft for too long.

CODICO has become like a second family to me, and I'm really looking forward to the years to come.

D05

▼ Alexander Grabner, +43 1 86305 206
alexander.grabner@codico.com

Thomas HORVATH

Dear Readers, my name is Thomas Horvath, and it's a real pleasure for me to get the chance introduce myself in this edition. I've been with CODICO since March 2011, working in Accounts and Time Acquisition.

In my main position in Accounts I deal with commercial goods purchases. Put more precisely, I check all the incoming invoices very carefully with regard to form specifications, then I enter them in our accounting system and book them with the corresponding delivery notes from Goods Reception. I'm also responsible for looking very carefully into any reminders we get from suppliers, and then taking the necessary action. I also back up my colleagues in Time Acquisition, and I also administer the data relating to our staff, in conjunction with my colleague from Personnel. As to my school career, I first graduated from a secondary technical school (HTL) in Electronics and Telecommunications, and afterwards took a Commercial Academy college qualification in Information Technology, which was precisely the right choice for my job.

To balance out my everyday work in the office, in my free time I often go walking and running in the countryside. Since my first year with CODICO I have also enjoyed taking part in the »Vienna Energy Business Run«. I love getting over the course with my colleagues, with so much team spirit. As well as my sporting activities, I also regularly watch sports competitions on TV, but I'm also keen on quiz shows and games shows with a touch of adventure, while I'm going full pelt on my ergometer bike. I spend a lot of time with my parents as well, and with my brother.

I enjoy my work at CODICO, and I value the great team spirit we all have. And that's why I look forward every day to taking on new challenges and conquering them.



Thomas Horvath

D06

▶ Thomas Horvath, +43 1 86305 156
thomas.horvath@codico.com

Steve PRICE

Hello CODICO fans! My name is Steve Price and I was very honoured to be chosen by CODICO during 2011 to become their new Regional Sales Manager covering sales of our Active components in the UK and Ireland.

Working for CODICO involves embracing all aspects of being European – the languages, the different cultures and, of course, the fantastic Austrian food and excellent local wine. I'm also extremely privileged to work with such a fantastic team!

My sad fascination for electronics started when I was 14 years old. I used to build guitar effects pedals and synthesiser keyboards – I think I fancied myself as the fifth member of Kraftwerk back then! Later on my interests turned to micro-controllers and writing programs using Assembler Language for various hobby kits including one by Sir Clive Sinclair that cost around €40 when I was 17 years old – spending hours on a program just to flash some LEDs! If only I'd kept that kit it would now be worth around €1K on Ebay!

So my first experience of working for a European Distributor was the understanding of »familiar« naming ... or maybe the lack of. Having been known by everyone as Steve for 50+ years I discovered, on joining CODICO, that our team had already printed my first name as Stephen on business cards, email address etc. Now only my Mother ever called me Stephen and that was only when I was in trouble!! So since 2011 you can imagine how strange this was after so many years hearing my full forename everywhere and thinking I was in trouble again! Still it's better than my nickname of »Twoburgers« that was given to me by the previous company I worked for. This came about following a visit to a well-known American Fast Food Burger establishment then ordering two burger meals only to be watched by a small boy who, clearly fascinated by my huge appetite, shouted out to his mother and everyone else at the top of his voice »Look Mum!..that man's just eaten two burgers!« ... oh the shame!

I've been married for just over 26 years to my lovely wife Diana. We live in the English countryside and have three amazing children, two cats, a dog and 6 chickens! So home life is never really quiet but there are always plenty of eggs! My hobbies include motorcycling, motorcycle restoration, clay pigeon shooting ... oh and still trying to become the 5th member of Kraftwerk!

I always enjoy meeting new customers and discussing new projects so I look forward to hearing from you soon! Let's Get Technical!



Steve Price

D07

▶ Steve Price, +44 1604 641156
stephen.price@codico.com

CODICO GmbH | Zwingenstrasse 6-8 | 2380 Perchtoldsdorf | Austria
Tel: +43 1 86 305-0 | Fax: +43 1 86 305-5000 | office@codico.com

www.codico.com

