



晶采光電科技股份有限公司
AMPIRE CO., LTD.

SPECIFICATIONS FOR LCD MODULE

CUSTOMER	
CUSTOMER PART NO.	
AMPIRE PART NO.	AM-800480ASTZQW-80H
APPROVED BY	
DATE	

Preliminary Specification

Approved Specification

AMPIRE CO., LTD.

**Building A., 4F., No.116, Sec. 1, Sintai 5th Rd., Xizhi Dist,
New Taipei City 221, Taiwan (R.O.C.)**

新北市汐止區新台五路一段 116 號 4 樓(東方科學園區 A 棟)

TEL:886-2-26967269 , FAX:886-2-26967196 or 26967270

APPROVED BY	CHECKED BY	ORGANIZED BY

RECORD OF REVISION

Revision Date	Page	Contents	Editor
2016/02/22	-		Lawlite

1. Features

8 inch Amorphous-TFT-LCD (Thin Film Transistor Liquid Crystal Display) module.

This module is composed of a 8" TFT-LCD panel and backlight unit.

- (1) Construction: 8" a-Si TFT active matrix, White LED Backlight .
- (2) Resolution (pixel): 800(R.G.B) X 480
- (3) Number of the Colors : 16.7M colors (R , G , B, 8 bit digital each)
- (4) LVDS interface

2. PHYSICAL SPECIFICATIONS

Item	Specifications	unit
Display resolution(dot)	800RGB (W) x 480(H)	dots
Active area	174.00 (W) x 104.40 (H)	mm
Pixel pitch	0.2175 (W) x 0.2175 (H)	mm
Color configuration	R.G.B Vertical stripe	
Overall dimension	192.8(W)x120.0(H)X9.6(T)	mm
Brightness	1500 nit	cd/m ²
Input Voltage	3.3	
Backlight unit	LED	
Display color	16.7M	Colors
Display Mode	Normally Black	

3. ABSOLUTE MAX. RATINGS

Item	Symbol	Min.	Max.	Unit	Note
Logic Supply Voltage	V _{DD}	-0.3	3.96	V	(1),(2)
Operating Temperature	T _{OP}	-20	70	°C	(3),(4),(5),(6),(7)
Storage Temperature	T _{ST}	-30	80	°C	

Note (1) Permanent damage may occur to the LCD module if beyond this specification.

Functional operation should be restricted to the conditions described under normal operating conditions.

Note (2) Operating temperature 25°C, humidity 55%RH.

Note (3) (T≤40°C) Note static electricity. Maximum wet bulb temperature at 39°C or less.

(T>40°C) No condensation.

Note (4) There is a possibility of causing deterioration in the irregularity and others of the screen and the display fineness though the liquid crystal module doesn't arrive at destruction when using it at 70~80°C

Note (5) There is a possibility of causing the fineness deterioration by the prolonged use in the (high temperature) humidity environment (60%RH or more).

Note (6) In the operating temperature item, the low temperature side is the ambient temperature regulations. The high temperature side is the panel surface temperature regulations.

4. ELECTRICAL CHARACTERISTICS

4-1 TFT LCD Module

Item	Symbol	Min.	Typ.	Max.	Unit	Note
LCD Supply Voltage	VCC	3.0	3.3	3.6	V	-
Logic Input Voltage	VIH	2.7	-	VCC	V	(2)
	VIL	0	-	0.5	V	(2)
LCD Supply Current	ICC	-	T.B.D	-	mA	(1)
Power Supply Voltage For LED Driver	VLED	--	12	--	V	(1)
Power Supply Current For LED Driver	ILED	--	T.B.D	--	mA	VLED =12V
LVDS DRIVER DC SPECIFICATIONS						
Differential Output Voltage	VOD	250	350	450	mV	RL=100ohm
Change in VOD between Complimentary Output States	Δ VOD	-	-	35	mV	
Common Mode Voltage	VOC	1.125	1.25	1.375	V	
Change in VOC between Complimentary Output States	Δ VOC	-	-	35	mV	
LVDS RECEIVER DC SPECIFICATIONS						
Differential Input High Threshold	VTH	-	-	+100	mV	VOC=+1.2V
Differential Input Low Threshold	VTL	-100	-	-	mV	

Note1: Ta=25°C , Display pattern : All Black

Note2: SDA,SCL,XRES .

4-2 Backlight Unit

Item	Symbol	Min.	Typ.	Max.	Unit	Note
LED Driver Voltage	VLED	--	12	--	V	
ADJ Input Voltage	V _{ADJ}	-	3.3	-	V	
LED voltage	V _{BL}	--	--	28	V	For reference
LED current	IBL	--	360	--	mA	Ta=25°C
LED Life Time	-	--	50K	--	Hour	Note (1)

Note (1) Brightness to be decreased to 50% of the initial value.

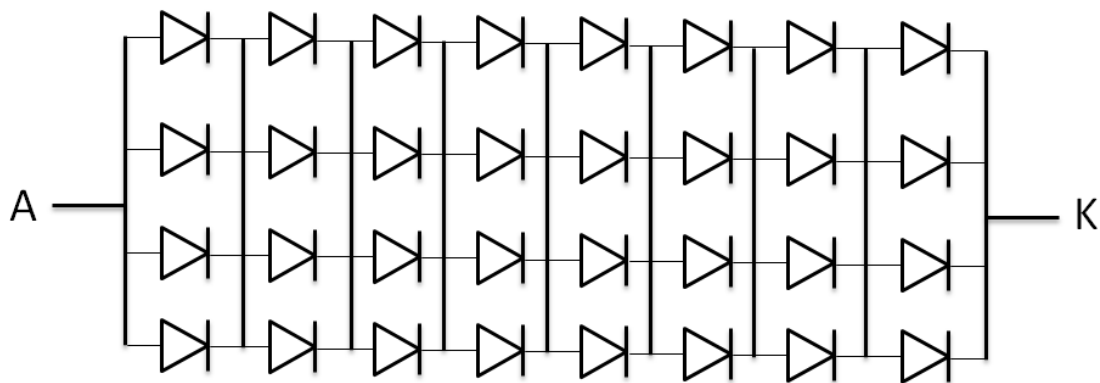

LED(4*8=32) CIRCUIT DIAGRAM

5. Timing Characteristics

5.1 HV Mode

Parameter	Symbol	Unit	Min.	Typ.	Max.
DCLK	fdclk	MHz	(21)	26.2	(38)
H Total Time	Tht	clocks	(828)	832	(1050)
H Front Porch	Thfp	clocks	(12)	16	(234)
H Pulse Width	THPw	clocks	(3)	8	(14)
H Back Porch	Thbp	clocks	(2)	8	(13)
H Active Time	HAt	clocks	800		
V Total Time	Tvt	lines	(500)	525	(560)
V Front Porch	Tvfp	lines	(17)	38	(75)
V Pulse Width	TVPw	lines	(1)	2	(4)
V Back Porch	Tvbp	lines	(1)	3	(4)
V Active Time	VAt	lines	480		
V Frequency	fv	Hz	50	60	65

Note: It is necessary to keep $TVP + TVB = 5$ and $THP + THB = 16$ in sync mode. DE mode is unnecessary to keep it.

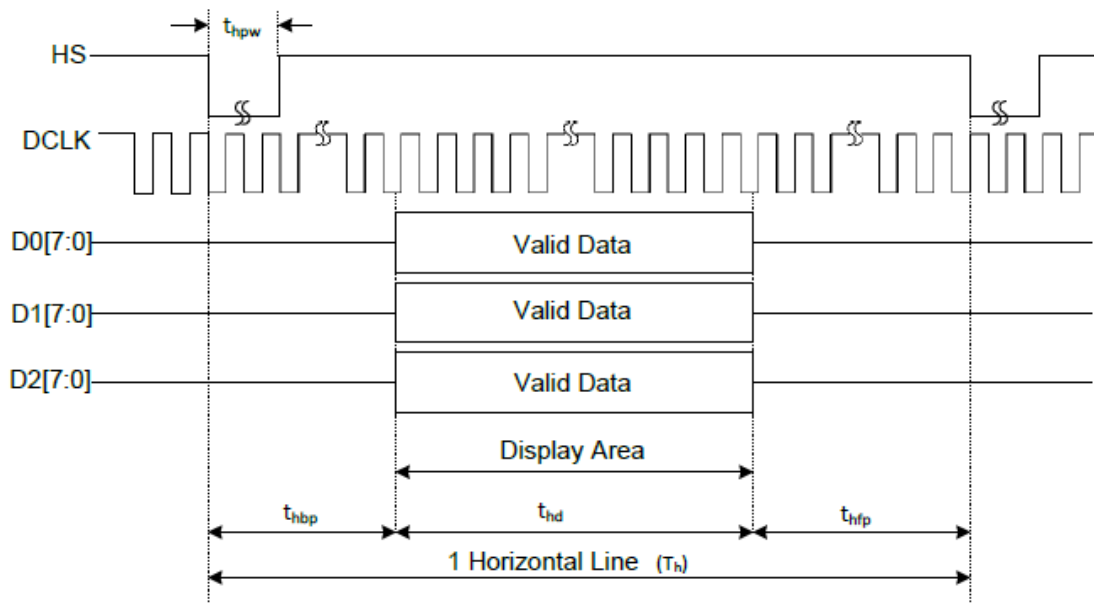

Horizontal input Timing at Sync mode

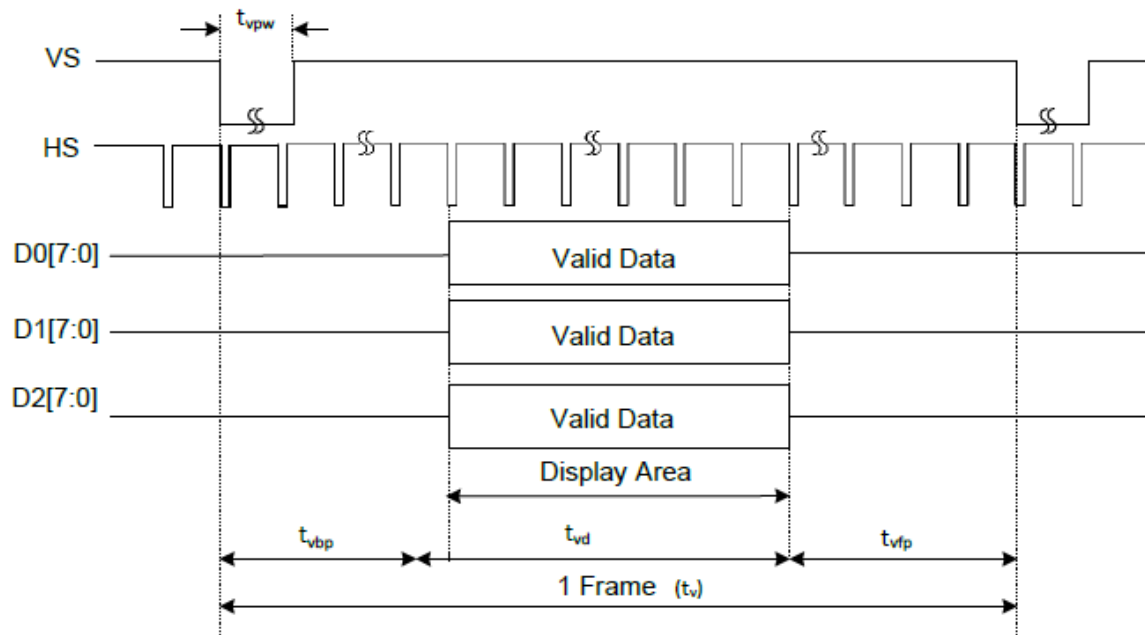

Vertical input Timing at Sync mode

5.2 DE Mode

Parameters	Symbol	Min	Typ	Max	Unit
DCLK Frequency	FDLCK	(21)	26.4	(38)	MHz
Horizontal Valid Data	Thd	800			clocks
1 Horizontal Line	Th	(828)	832	(1050)	clocks
Vertical Valid Data	Tvd	480			lines
1 Vertical Field	Tv	(500)	525	(560)	lines
Frame Rate	FR	(50)	60	(65)	Hz

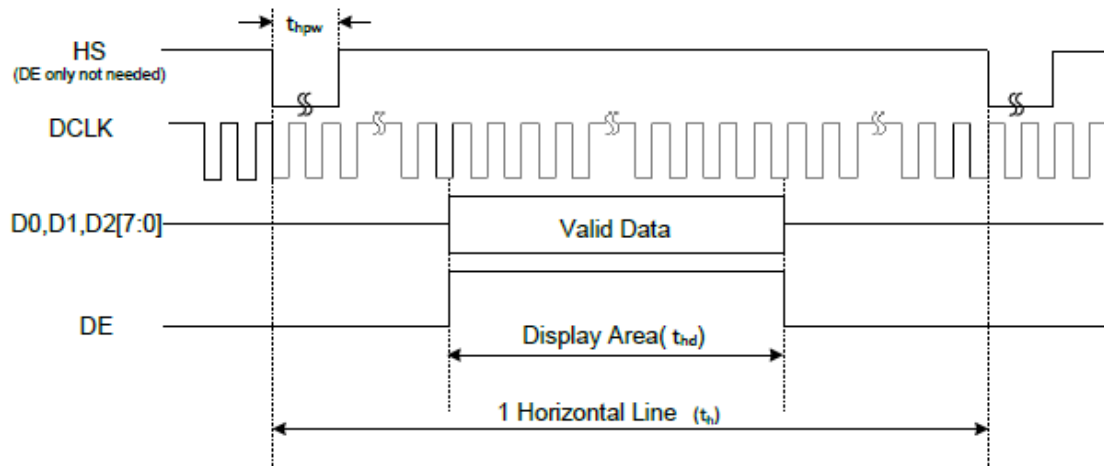

Horizontal input Timing at DE only mode

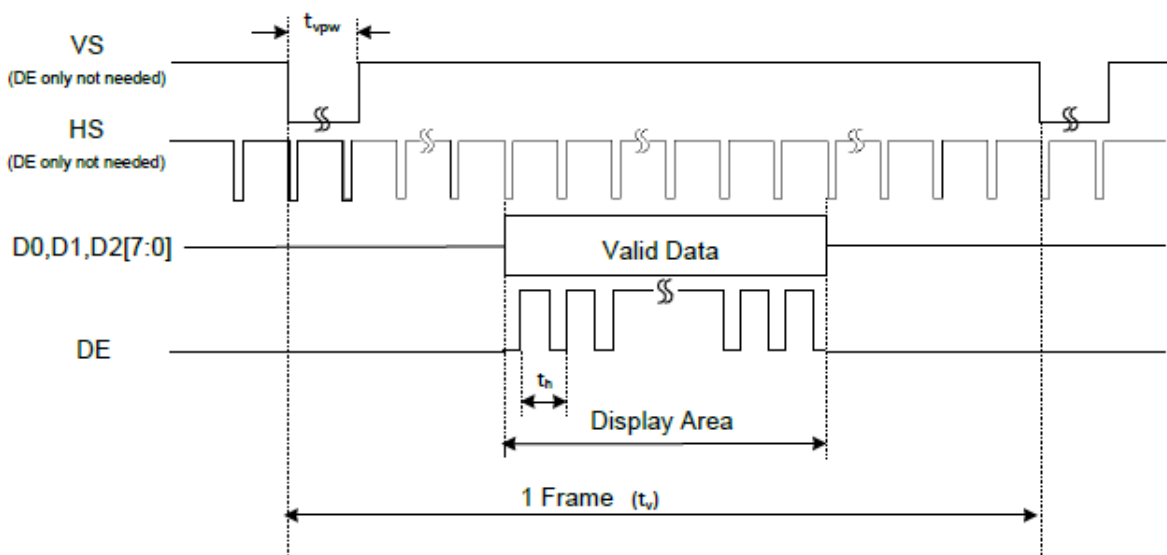

Vertical input Timing at DE only mode

6. Optical Specifications

Item	Conditions	Min.	Typ.	Max.	Unit	Note	
Viewing Angle (CR>10) ☆	Horizontal	θ_{x+}	-	(89)	-	degree	(1),(2),(3)
		θ_{x-}	-	(89)	-		
	Vertical	θ_{y+}	-	(89)	-		
		θ_{y-}	-	(89)	-		
Contrast Ratio☆	Center	(800)	(900)	-	-	(1),(2),(4),(6) $\theta_x=\theta_y=0^\circ$	
Response Time	Rising + Falling	25°C	-	(30)	(40)	ms	(1),(2),(5) $\theta_x=\theta_y=0^\circ$
		-20°C	-	(250)	(300)		
		-30°C	-	(330)	(350)		
Color Chromaticity (CIE1931) ☆	Red x	Typ. -0.05	Typ. +0.05	(0.645)	-	(1),(2),(3) $\theta_x=\theta_y=0^\circ$	
	Red y			(0.337)	-		
	Green x			(0.297)	-		
	Green y			(0.606)	-		
	Blue x			(0.147)	-		
	Blue y			(0.065)	-		
	White x			(0.301)	-		
	White y			(0.333)	-		
NTSC☆	-	-	(72)	-	%	(1),(2),(3) $\theta_x=\theta_y=0^\circ$	
Transmittance☆	-	(3.9)	(4.3)	-	%	(1),(2) $\theta_x=\theta_y=0^\circ$	

Note (1) Measurement Setup:

The LCD module should be stabilized at given temperature (25°C) for 15 minutes to avoid abrupt temperature change during measuring. In order to stabilize the luminance, the measurement should be executed after lighting backlight for 15 minutes in a windless room.

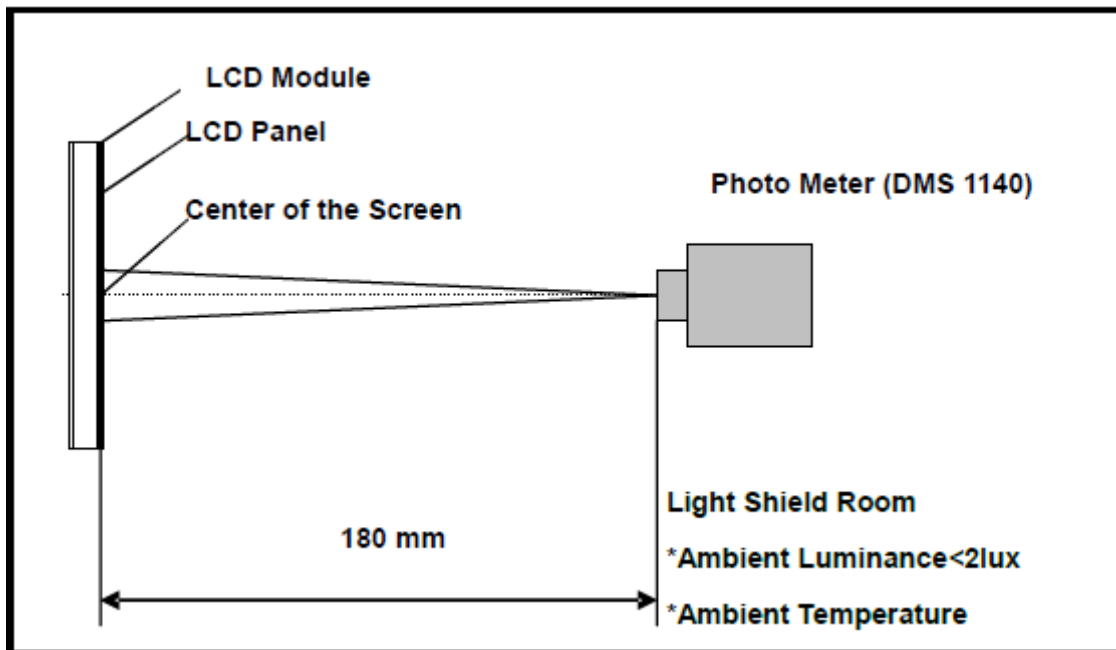

Measurement Setup

Note (2) B/L Spectrum Graph

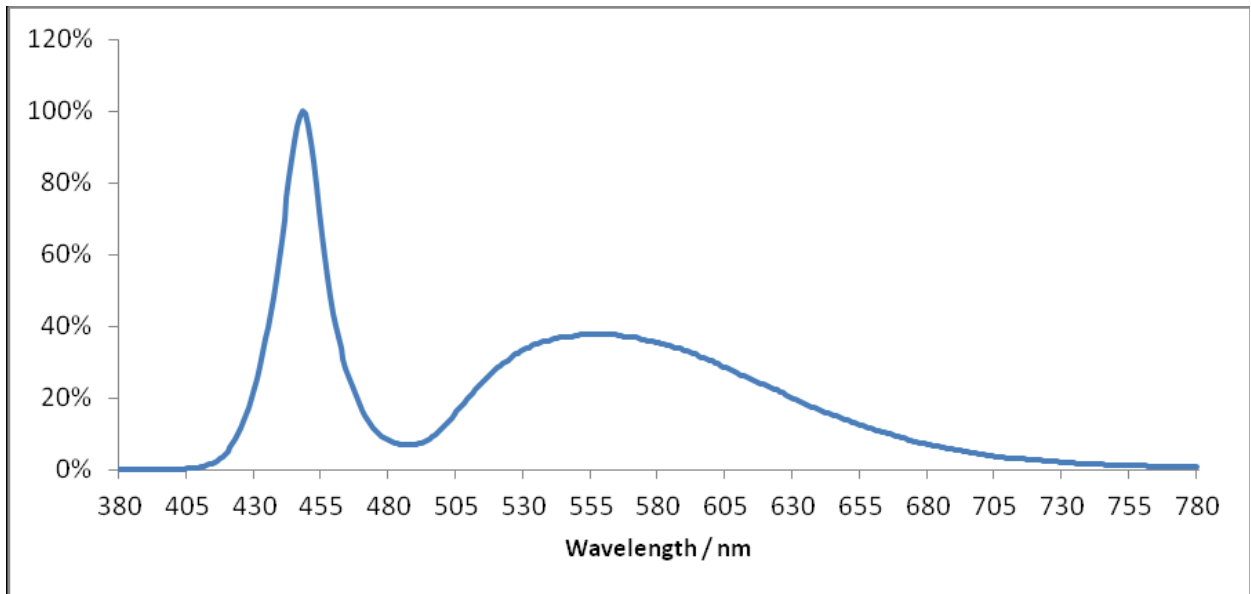

B/L Spectrum Graph for reference

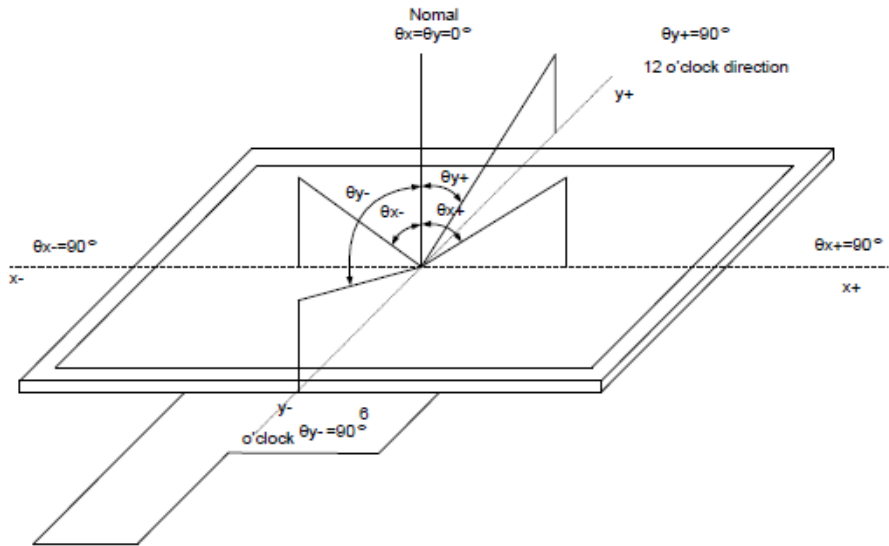

Definition of Viewing Angle

Note (4) Definition Of Contrast Ratio (CR)

The contrast ratio can be calculated by the following expression:

$$\text{Contrast Ratio (CR)} = L255 / L0$$

L255: Luminance of gray level 255, L0: Luminance of gray level 0

Note (5) Definition Of Response Time (TR, TF)

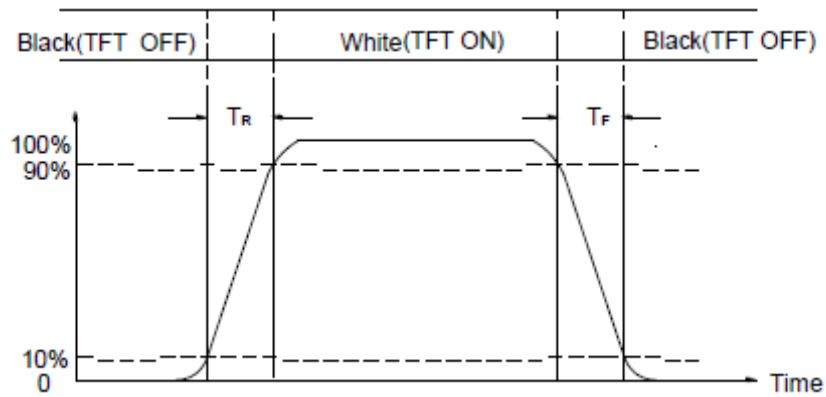

Definition of Response Time

Note (6) IVO only guarantee Contrast as below,

L/R/U/D: 35/35/0/0, CR ≥ 25% of Center L/R/U/D:

0/0/35/35, CR ≥ 20% of Center L/R/U/D:

45/45/0/0, CR ≥ 15% of Center

7. INTERFACE

Pin No.	Symbol	Function
1	VDD	POWER SUPPLY:3.3V
2	VDD	POWER SUPPLY:3.3V
3	GND	Power Ground
4	GND	Power Ground
5	IN0-	Transmission Data of Pixels
6	IN0+	Transmission Data of Pixels
7	GND	Power Ground
8	IN1-	Transmission Data of Pixels 1
9	IN1+	Transmission Data of Pixels 1
10	GND	Power Ground
11	IN2-	Transmission Data of Pixels 2
12	IN2+	Transmission Data of Pixels 2
13	GND	Power Ground
14	CLK-	Sampling Clock
15	CLK+	Sampling Clock
16	GND	Power Ground
17	VLED	POWER SUPPLY for Backlight
18	VLED	POWER SUPPLY for Backlight
19	GND	Power Ground
20	LEDADJ	LED PWM SIGNAL

8. Reliability Test Items

Test Item	Test Conditions	Note
High Temperature Operation	70±3°C , t=240 hrs	
Low Temperature Operation	-20±3°C , t=240 hrs	
High Temperature Storage	80±3°C , t=240 hrs	1,2
Low Temperature Storage	-30±3°C , t=240 hrs	1,2
Storage at High Temperature and Humidity	60°C, 90% RH , 240 hrs	1,2
Thermal Shock Test	-20°C (30min) ~ 70°C (30min) 100 cycles	1,2
Vibration Test (Packing)	Sweep frequency : 10 ~ 55 ~ 10 Hz/1min Amplitude : 0.75mm Test direction : X.Y.Z/3 axis Duration : 30min/each axis	2

Note 1 : Condensation of water is not permitted on the module.

Note 2 : The module should be inspected after 1 hour storage in normal conditions
(15-35°C , 45-65%RH).

9. General Precautions

9.1 Use Restriction

This product is not authorized for use in life supporting systems, aircraft navigation control systems, military systems and any other application where performance failure could be life-threatening or otherwise catastrophic.

9.2 Handling Precaution

- (1) Please mount LCD panel by using mounting holes arranged in four corners tightly.
- (2) Do not disassemble or modify the panel. It may damage sensitive parts inside LCD panel, and may cause scratches or dust on the display. IVO does not warrant the panel, if customers disassemble or modify the panel.
- (3) If LCD panel is broken and liquid crystal spills out, do not ingest or inhale liquid Crystal, and do not contact liquid crystal with skin. If liquid crystal contacts mouth or eyes, rinse out with water immediately. If liquid crystal contacts skin or cloths, wash it off immediately with alcohol and Rinse thoroughly with water.
- (4) Disconnect power supply before handling LCD panel
- (5) Refrain from strong mechanical shock and /or any force to the panel.
- (6) Do not exceed the absolute maximum rating values, such as the supply voltage variation, input voltage variation, variation in parts' parameters, environmental temperature; etc otherwise LCD panel may be damaged. It's recommended employing protection circuit for power supply.
- (7) Do not touch, push or rub the polarizer with anything harder than HB pencil lead. Use fingerstalls of soft gloves in order to keep clean display quality, when Persons handle the LCD panel for incoming inspection or assembly.
- (8) When the surface is dusty, please wipe gently with absorbent cotton or other soft Material. When cleaning the adhesives, please use absorbent cotton wetted with a little Petroleum benzene or other adequate solvent.
- (9) Wipe off saliva or water drops as soon as possible. If saliva or water drops Contact with polarizer for a long time, they may causes deformation or color Fading.
- (10) Protection film must remove very slowly from the surface of LCD panel to Prevent from electrostatic occurrence.
- (11) Because LCD panel uses CMOS-IC on circuit board and TFT-LCD panel, it is Very weak to electrostatic discharge, Please be careful with electrostatic Discharge .Persons who handle the panel should be grounded through adequate methods.
- (12) Do not adjust the variable resistor located on the panel.

9.3 Storage Precaution

- (1) Please do not leave LCD panel in the environment of high humidity and high temperature for a long time.
- (2) The panel shall not be exposed under strong light such as direct sunlight. Otherwise, display characteristics may be changed.
- (3) The panel should be stored in a dark place. It is prohibited to apply sunlight or fluorescent light in storage.

9.4 Operation Precaution

- (1) Do not connect or disconnect the module in the "Power On" condition.
- (2) Power supply should always be turned on/off by "Power On/Off Sequence".
- (3) Module has high frequency circuits. Sufficient suppression to the electromagnetic interference should be done by system manufacturers. Grounding and shielding methods may be important to minimize the interference.
- (4) After installation of the TFT panel into an enclosure, do not twist nor bend the TFT panel even momentary. At designing the enclosure, it should be taken into consideration that no bending/twisting forces are applied to the TFT panel from outside. Otherwise the TFT panel may be damaged.
- (5) Do not keep the LCD at the same display pattern continually. The residual image will happen and it will damage the LCD. Please use screen saver.

9.5 Others

- (1) Ultra-violet ray filter is necessary for outdoor operation.
- (2) Avoid condensation of water which may result in improper operation or disconnection of electrode.
- (3) If the panel keeps displaying the same pattern for a long period of time, the image may be "sticked" to the screen.

9.6 Disposal

When disposing LCD panel, obey the local environmental regulations.

10. OUTLINE DIMENSION

REV	REVISION RECORD	DATE	NAME
0	NEW RELEASE	12-02-15	EMILY

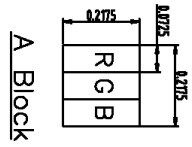

1	VDD	11	IN2-
2	VDD	12	IN2+
3	GND	13	GND
4	GND	14	CLK-
5	INO-	15	CLK+
6	INO+	16	GND
7	GND	17	VLED
8	IN1-	18	VLED
9	IN1+	19	GND
10	GND	20	ADJ

Note:
 1. Unless indicated, Tolerance "±0.3"
 2. UV Glue For OLB Protection.

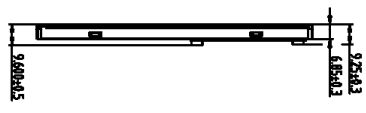
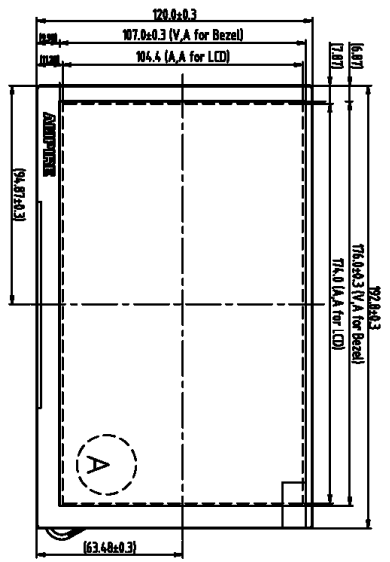

1	8.0' 800x480 FOG IPS	7		TOLERANCE	GRADE(F)	A	B	DIM.	NEW	DWN.	EMILY	DATE	12-02-15
2	LED 1500nits	8						IE NO.		CHK.		DATE	
3	New Bezel	9											
4	New PCB (LED Driver)	10											
5		11											
6		12											
									PARTS NO. ICM	APPRD.	DATE		
									800480AS-50				

AMPIRE
 晶采光电科技

TITLE
800480AS-50
 (8.0")
 DWG. NO.
 *151210MA SHEET 1 OF 1

