



晶采光電科技股份有限公司  
AMPIRE CO., LTD.

## SPECIFICATIONS FOR LCD MODULE

<b>CUSTOMER</b>	
<b>CUSTOMER PART NO.</b>	
<b>AMPIRE PART NO.</b>	<b>AC-204ASTQW-70H-A(R)</b>
<b>APPROVED BY</b>	
<b>DATE</b>	

- Approved For Specifications
- Approved For Specifications & Sample

**AMPIRE CO., LTD.**

**2F., No.88, Sec. 1, Sintai 5th Rd., Sijhih City, Taipei County 221,  
Taiwan (R.O.C.)台北縣汐止市新台五路一段88號2樓(東方科學園區D棟)  
TEL:886-2-26967269 , FAX:886-2-26967196 or 26967270**

<b>APPROVED BY</b>	<b>CHECKED BY</b>	<b>ORGANIZED BY</b>

## RECORD OF REVISION

Revision Date	Page	Contents	Editor
2009/5/19	-	New Release	Edward

## 1 FEATURES

- (1) Display format : 20 characters × 4 lines
- (2) Construction : LCD, Bezel, Zebra ,White Edge LED back-light and PCB.
- (3) Display type : STN Negative Type , 6 o'clock view.
- (4) Controller : ST7066U-0A or Equivalent.
- (5) +5V single power input.
- (6) Extended temperature type.
- (7) Excellent LC : VOP maintains at 5V for whole temp. range, no need extra temp. compensation circuit.
- (8) ROHS compliant.

## 2 MECHANICAL DATA

Parameter	Stand Value	Unit
Dot size	0.55(W) × 0.55(H)	mm
Dot pitch	0.60(W) × 0.60(H)	mm
Character size	2.95(W) × 4.75(H)	mm
Viewing area	76.0(W) × 25.2(H)	mm
Module size	98.0(W) × 60.0(H) × 14.5 max (T)	mm

## 3 ABSOLUTE MAXIMUM RATINGS

Parameter	Symbol	Min	Max	Unit	
Logic Circuit Supply Voltage	VDD-VSS	-0.3	7.0	V	
LCD Driving Voltage	VDD-VO	-0.3	10.0	V	
Input Voltage	VI	-0.3	VDD+0.3	V	
Extended temp. type	Operating Temp.	TOP	-20	70	°C
	Storage Temp.	TSTG	-30	80	°C

## 4 ELECTRO-OPTICAL CHARACTERISTICS

Parameter	Symbol	Condition	Min	Typ	Max	Unit	Note
<b>----- Electronic Characteristics -----</b>							
Logic Circuit Supply Voltage	VDD-VSS	--	4.5	5.0	5.5	V	
LCD Driving Voltage	VDD-VO	-20 °C	4.75	5.0	5.25	V	
		25 °C	4.75	5.0	5.25		
		70 °C	4.75	5.0	5.25		
Input Voltage	VIH	--	0.7 VDD	--	VDD	V	
	VIL	--	VSS	--	0.3 VDD	V	
Logic Supply Current	IDD	VDD = 5V	--	1.5	2.0	mA	
<b>----- Optical Characteristics -----</b>							
Contrast	CR	25°C	--	5	--		Note 1
Rise Time	Tr	25°C	--	200	300	ms	Note 2
Fall Time	Tf	25°C	--	200	300	ms	
Viewing Angle Range	$\theta f$	25°C & CR $\geq$ 2	--	35	--	Deg.	Note 3
	$\theta b$		--	25	--		
	$\theta l$		--	30	--		
	$\theta r$		--	30	--		
Frame Frequency	FF	25°C	--	64	--	Hz	
<b>----- White LED Back-light Characteristics -----</b>							
Parameter	Symbol	Condition	Min	Typ	Max	Unit	Note
Forward Current	IF	--	--	30	40	mA	Note 4 & 7
LCM Luminous intensity (Full White pattern)		IF=30mA	--	9	--	cd/m <sup>2</sup>	Note 4
Forward Voltage	VF	IF=30mA	--	3.2	3.5	V	Note 5
LED C.I.E	X	IF=30mA	0.26	0.30	0.34		Note 6
	Y	IF=30mA	0.27	0.31	0.35		

Note 4: Luminous intensity is decided by forward current of White LED.

Note 5: White LEDs are with voltage tolerance

Note 6: White LEDs are with color tolerance

\* LED Dice number = 2

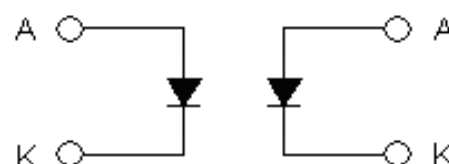

(NOTE 1) Contrast ratio :

$$CR = (\text{Brightness in ON state}) / (\text{Brightness in OFF state})$$

( NOTE 2 ) Response time :

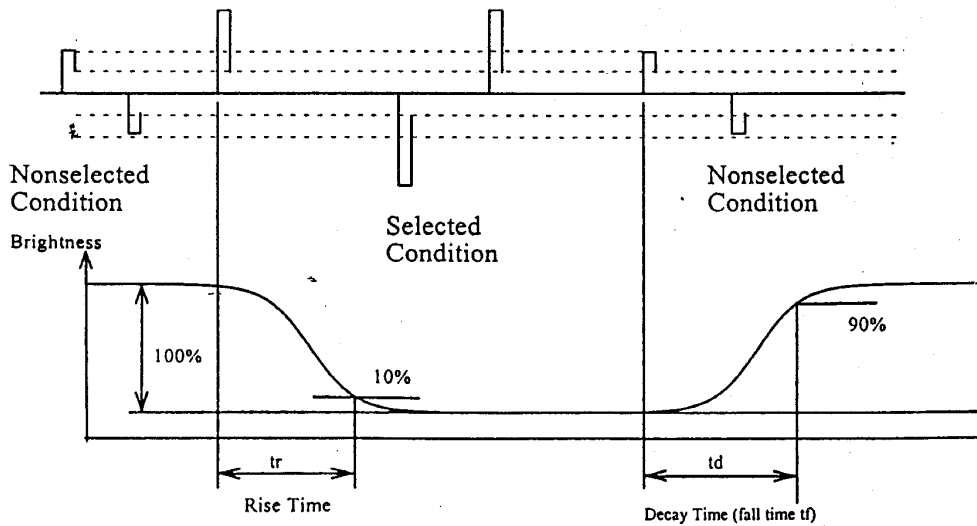

(NOTE 3) Viewing angle

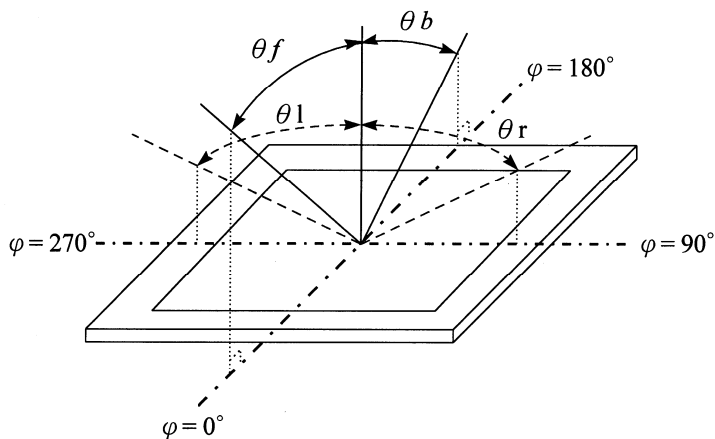

(NOTE 7) One LED Current Diagram

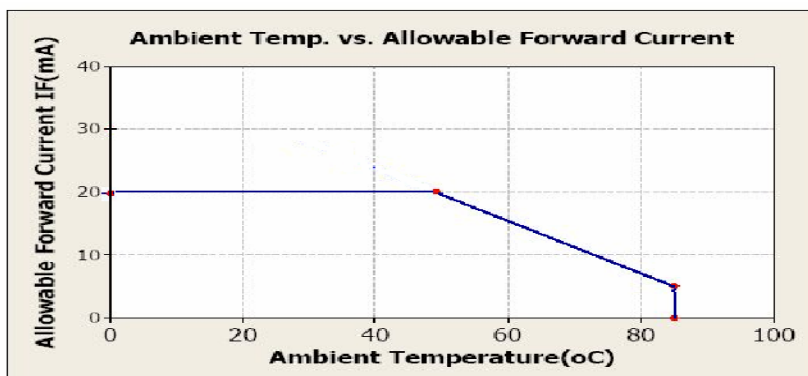

## 5 BLOCK DIAGRAM & INTERFACE

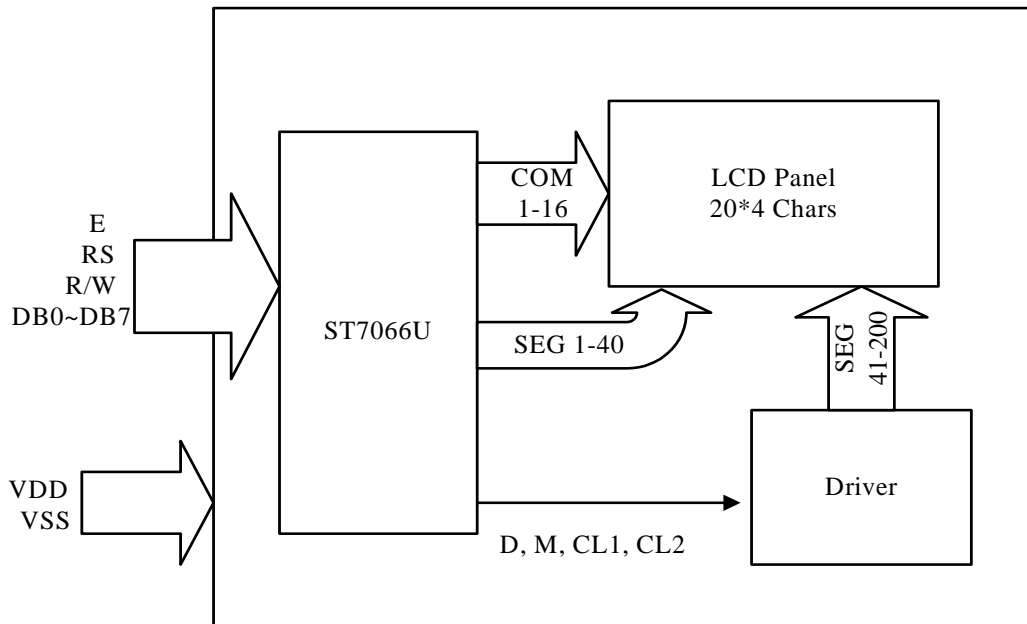

No.	Symbol	Function
1	VSS	Ground (0V)
2	VDD	Supply Voltage for Logic (+5V)
3	VO	Contrast Adjustment
4	RS	Data/Instruction Select
5	R/W	Read/Write Select
6	E	Enable Signal
7	DB0	Data Bus
8	DB1	Data Bus
9	DB2	Data Bus
10	DB3	Data Bus
11	DB4	Data Bus
12	DB5	Data Bus
13	DB6	Data Bus
14	DB7	Data Bus
15	LED_A	LED Power input (+5V)
16	LED_K	LED Power input (0V)

# 6 POWER SUPPLY

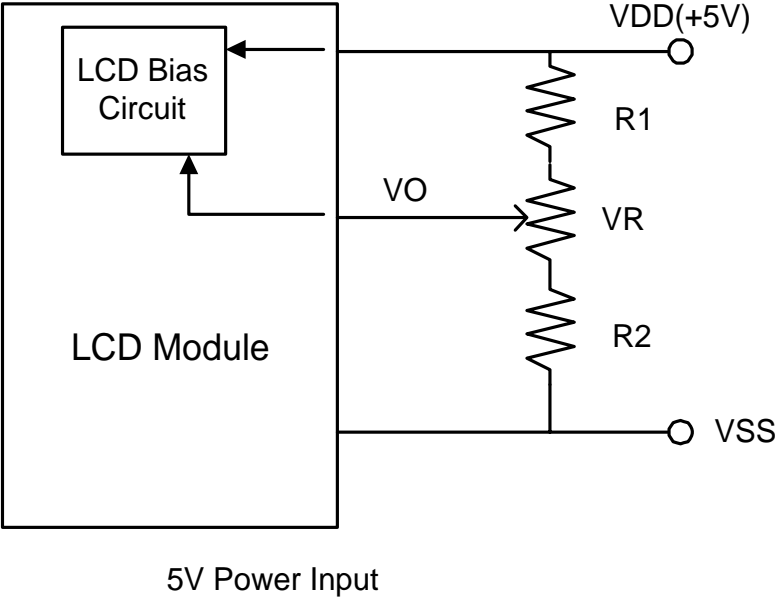

Using LED Back-light

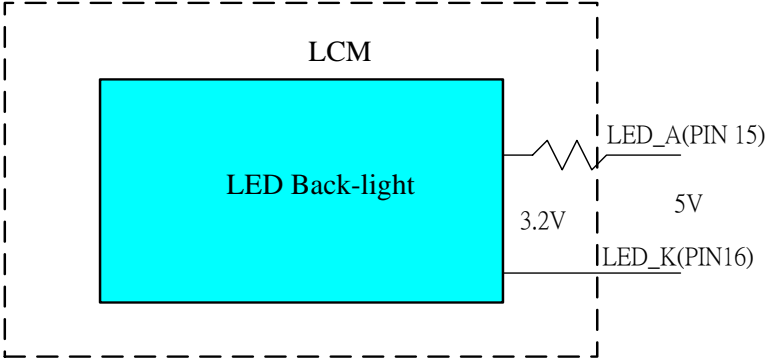

## 7 TIMING CHARACTERISTICS

### Write Operation

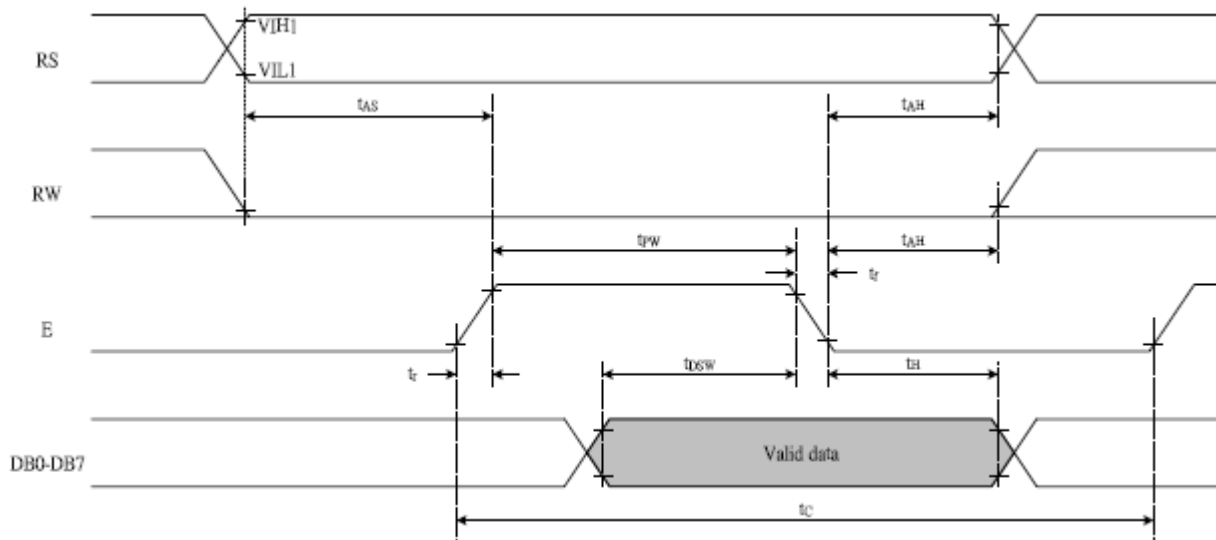

VDD = 5.0V

Symbol	Characteristics	Test Condition	Min.	Max.	Unit
<i>Write Mode (Writing data from MPU to ST7066U)</i>					
$T_C$	Enable Cycle Time	Pin E	1200	-	ns
$T_{PW}$	Enable Pulse Width	Pin E	140	-	ns
$T_R, T_F$	Enable Rise/Fall Time	Pin E	-	25	ns
$T_{AS}$	Address Setup Time	Pins: RS,RW,E	0	-	ns
$T_{AH}$	Address Hold Time	Pins: RS,RW,E	10	-	ns
$T_{DSW}$	Data Setup Time	Pins: DB0 - DB7	40	-	ns
$T_H$	Data Hold Time	Pins: DB0 - DB7	10	-	ns



## Read Operation

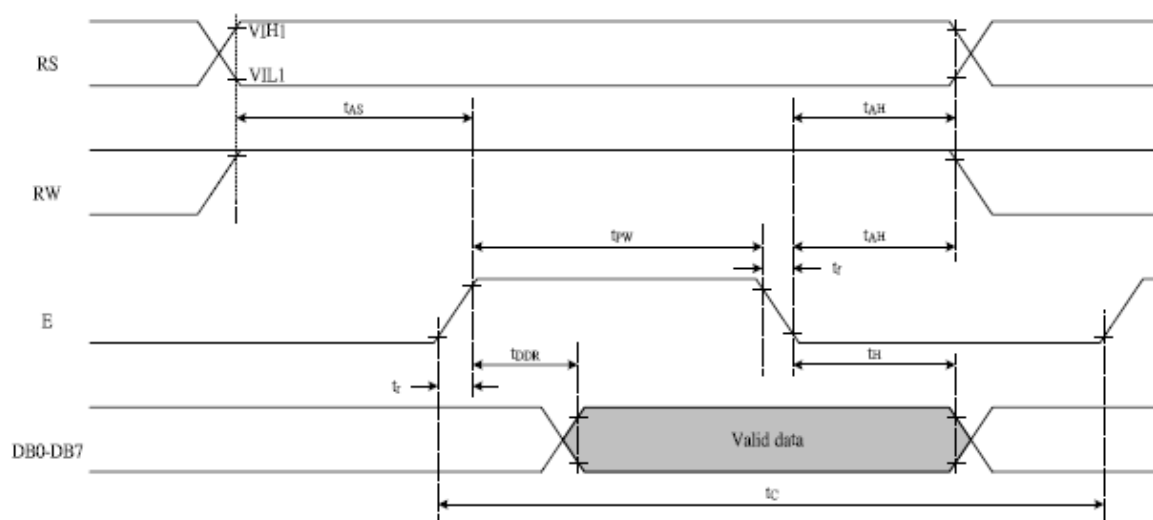

VDD = 5.0V

Symbol	Characteristics	Test Condition	Min.	Max.	Unit
<i>Read Mode (Reading Data from ST7066U to MPU)</i>					
$T_C$	Enable Cycle Time	Pin E	1200	-	ns
$T_{PW}$	Enable Pulse Width	Pin E	140	-	ns
$T_R, T_F$	Enable Rise/Fall Time	Pin E	-	25	ns
$T_{AS}$	Address Setup Time	Pins: RS,RW,E	0	-	ns
$T_{AH}$	Address Hold Time	Pins: RS,RW,E	10	-	ns
$T_{DDR}$	Data Setup Time	Pins: DB0 - DB7	-	100	ns
$T_H$	Data Hold Time	Pins: DB0 - DB7	10	-	ns

## 8 INSTRUCTION SET

Instruction	Instruction Code										Description	Description Time (270KHz)
	RS	R/W	DB7	DB6	DB5	DB4	DB3	DB2	DB1	DB0		
Clear Display	0	0	0	0	0	0	0	0	0	1	Write "20H" to DDRAM. and set DDRAM address to "00H" from AC	1.52 ms
Return Home	0	0	0	0	0	0	0	0	1	x	Set DDRAM address to "00H" from AC and return cursor to its original position if shifted. The contents of DDRAM are not changed.	1.52 ms
Entry Mode Set	0	0	0	0	0	0	0	1	I/D	S	Sets cursor move direction and specifies display shift. These operations are performed during data write and read.	37 us
Display ON/OFF	0	0	0	0	0	0	1	D	C	B	D=1:entire display on C=1:cursor on B=1:cursor position on	37 us
Cursor or Display Shift	0	0	0	0	0	1	S/C	R/L	x	x	Set cursor moving and display shift control bit, and the direction, without changing DDRAM data.	37 us
Function Set	0	0	0	0	1	DL	N	F	x	x	DL:interface data is 8/4 bits N:number of line is 2/1 F:font size is 5x11/5x8	37 us
Set CGRAM address	0	0	0	1	AC5	AC4	AC3	AC2	AC1	AC0	Set CGRAM address in address counter	37 us
Set DDRAM address	0	0	1	AC6	AC5	AC4	AC3	AC2	AC1	AC0	Set DDRAM address in address counter	37 us
Read Busy flag and address	0	1	BF	AC6	AC5	AC4	AC3	AC2	AC1	AC0	Whether during internal operation or not can be known by reading BF. The contents of address counter can also be read.	0 us
Write data to RAM	1	0	D7	D6	D5	D4	D3	D2	D1	D0	Write data into internal RAM (DDRAM/CGRAM)	37 us
Read data from RAM	1	1	D7	D6	D5	D4	D3	D2	D1	D0	Read data from internal RAM (DDRAM/CGRAM)	37 us

**Note:**

Be sure the ST7066U is not in the busy state (BF = 0) before sending an instruction from the MPU to the ST7066U. If an instruction is sent without checking the busy flag, the time between the first instruction and next instruction will take much longer than the instruction time itself. Refer to Instruction Table for the list of each instruction execution time.

## 9 INITIALIZATION SEQUENCE

- 8-bit Interface (fosc=270KHz)

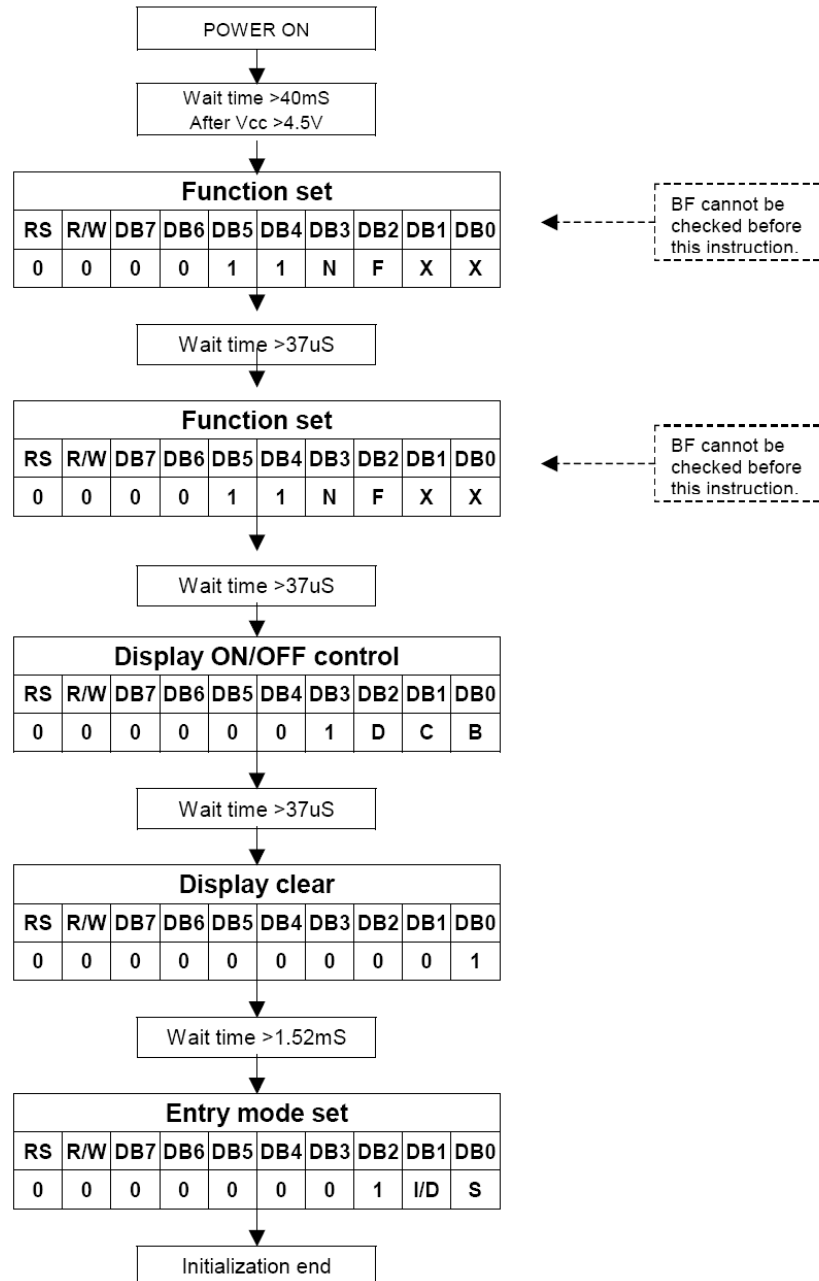

## 10 DD RAM ADDRESS

CHAR.	1	2	3	...	18	19	20
LINE 1	00	01	02	...	11	12	13
LINE 2	40	41	42	...	51	52	53
LINE 3	14	15	16	...	25	26	27
LINE 4	54	55	56	...	65	66	67

# 11 FONT TABLE

NO.7066-0A

b7-b4 b3-b0	0000	0001	0010	0011	0100	0101	0110	0111	1000	1001	1010	1011	1100	1101	1110	1111
0000	CG RAM (1)			0	a	P	^	P				—	3	3	3	P
0001	(2)		!	1	A	Q	a	9			a	7	7	4	3	q
0010	(3)		"	2	B	R	b	r			r	4	9	x	p	e
0011	(4)		#	3	C	S	c	s			l	7	T	E	S	w
0100	(5)		\$	4	D	T	d	t			\	I	T	T	W	o
0101	(6)		%	5	E	U	e	u			.	7	7	1	3	U
0110	(7)		&	6	F	V	f	v			7	7	2	3	p	z
0111	(8)		*	7	G	W	g	w			7	7	x	7	g	n
1000	(1)		<	8	H	X	h	x			4	7	*	U	J	X
1001	(2)		>	9	I	Y	i	y			5	7	J	W	7	Y
1010	(3)		*	:	J	Z	j	z			E	3	0	V	J	7
1011	(4)		+	;	K	L	k	l			*	7	E	0	*	n
1100	(5)		,	<	L	7	l	l			7	3	7	7	7	n
1101	(6)		—	=	N	I	n	7			u	z	\	U	E	7
1110	(7)		.	>	N	^	n	*			3	E	7	^	n	
1111	(8)		/	?	O	_	o	e			w	U	7	^	o	

## **12 QUALITY AND RELIABILITY**

### **12.1 TEST CONDITIONS**

Tests should be conducted under the following conditions :

Ambient temperature :  $25 \pm 5^{\circ}\text{C}$

Humidity :  $60 \pm 25\% \text{ RH}$ .

### **12.2 SAMPLING PLAN**

Sampling method shall be in accordance with MIL-STD-105E, inspection level II, normal inspection, and single sampling plan tables for normal, tightened, and reduced inspection.

### **12.3 ACCEPTABLE QUALITY LEVEL**

A major defect is defined as one that could cause failure to or materially reduce the usability of the unit for its intended purpose. A minor defect is one that does not materially reduce the usability of the unit for its intended purpose or is an infringement from established standards and has no significant bearing on its effective use or operation.

### **12.4 APPEARANCE**

An appearance test should be conducted by human sight at approximately 30 cm distance from the LCD module under fluorescent light. The inspection area of LCD panel shall be within the range of following limits.

## 12.5 INSPECTION QUALITY CRITERIA

ITEM	Description of defects			Class of defects	remark	
Function	No display		Reject	Major		
	Display abnormal		Reject	Major		
	Missing line		Reject	Major		
Black spots	Ave. dia. D		Area A	Area B	Minor	Two spots must be between about 5 mm
	$D \leq 0.13$		Disregard			
	$0.13 < D \leq 0.15$		2	2		
	$0.13 < D \leq 0.25$		1	2		
	$0.25 < D$		0	1		
Black line	Width W	Length L	Area A	Area B	Minor	
	$\leq 3.0$	$\leq 0.02$	Disregard			
	$\leq 2.0$	$\leq 0.04$	2	2		
	$\leq 1.0$	$\leq 0.06$	1	2		
		$> 0.06$	0	0		
Scratch	Width W		Length L	Accept	Minor	
	$W \leq 0.02$		-----	Disregard		
	$0.02 \leq W \leq 0.05$		$L \leq 3.0$	2		
	$W > 0.05$		-----	0		
Appearance	PCB copper circuit showed		Reject		Minor	
	PCB scratch was over 5 mm		Reject			
	Sort pad was damaged		Reject			
★ Back-Light	Function didn't work		Reject		Major	
	Some area didn't work		Reject			
	Bright was not even		Reject			
	B/L color was not correct		Reject			
★ T/P (DOTS)	$D \leq 0.2\text{mm}$		Reject		Major	
	$0.2\text{mm} < D \leq 0.3\text{mm}$		Reject			
	$0.3\text{mm} < D$		Reject			
★ T/P(Scratch)	$W \leq 0.02\text{mm}$		$10\text{mm} < L$	Disregard	Major	
	$0.05\text{mm} \leq W \leq 0.1\text{mm}$		$10\text{mm} < L$	1		
	$0.1\text{mm} \leq W$		$10\text{mm} < L$	0		
『★』 Symbol means LCM has this material.						

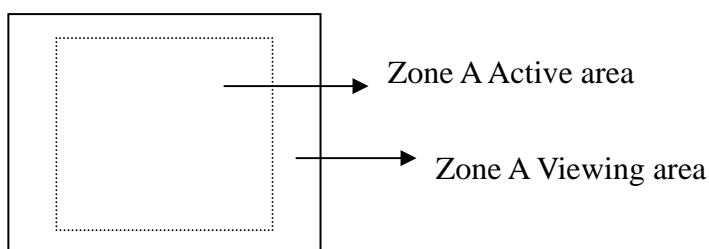

## 12.6 RELIABILITY

Test Item	Test Conditions	Note
	Extended Temp. type	
High Temperature Operation	70±3°C , t=96 hrs	
Low Temperature Operation	-20±3°C , t=96 hrs	
High Temperature Storage	80±3°C , t=96 hrs	1,2
Low Temperature Storage	-30±3°C , t=96 hrs	1,2
Thermal Shock Test	-30°C ~ 25°C ~ 80°C 30 min. 5 min. 30 min. ( 1 cycle ) Total 5 cycle	1,2
Humidity Test	40 °C, Humidity 90%, 96 hrs	1,2
Vibration Test (Packing)	Sweep frequency : 10 ~ 55 ~ 10 Hz/1min Amplitude : 0.75mm Test direction : X.Y.Z/3 axis Duration : 30min/each axis	2

Note 1 : Condensation of water is not permitted on the module.

Note 2 : The module should be inspected after 1 hour storage in normal conditions  
(15-35°C , 45-65%RH).

Definitions of life end point :

- Current drain should be smaller than the specific value.
- Function of the module should be maintained.
- Appearance and display quality should not have degraded noticeably.
- Contrast ratio should be greater than 50% of the initial value.

### **13 HANDLING PRECAUTIONS**

- (1) A LCD module is a fragile item and should not be subjected to strong mechanical shocks.
- (2) Avoid applying pressure to the module surface. This will distort the glass and cause a change in color.
- (3) Under no circumstances should the position of the bezel tabs or their shape be modified.
- (4) Do not modify the display PCB in either shape or positioning of components.
- (5) Do not modify or move location of the zebra or heat seal connectors.
- (6) The device should only be soldered to during interfacing. Modification to other areas of the board should not be carried out.
- (7) In the event of LCD breakage and resultant leakage of fluid do not inhale, ingest or make contact with the skin. If contact is made rinse immediately.
- (8) When cleaning the module use a soft damp cloth with a mild solvent, such as Isopropyl or Ethyl alcohol. The use of water, ketone or aromatic is not permitted.
- (9) Prior to initial power up input signals should not be applied.
- (10) Protect the module against static electricity and observe appropriate anti-static precautions.
- (11) AMIPRE will provide one year warrantee for all products and three months warrantee for all repairing products.



# 14 OUTLINE DIMENSION

REV	REVISION RECORD	DATE	NAME
1	NEW RELEASE	3-31-98	Army G
2	Add 204AL 通用品號		沈永明 / SNOW
3	Add AC204ALGLY-63		沈永明 / EMILY
4	Add AC204ALXX-530		沈永明 / SNOW
5	Add AC204ALXX-75		陳曉明 / SNOW
6	Add AC204ALXX-67/71		陳曉明 / SNOW

No.	適用品號
8	-502/-75
7	-26/-27/-50/-58/-60
6	-00/-05/-06/-13/-14
5	-71 (黑色高櫃)
4	-501/-63/-530/-67 (黑色高櫃)
3	-52/-53/-56/-62 (黑色高櫃)
2	-09/-12/-15/-51 (黑色高櫃)
1	-02/-03/-04/-07 (黑色高櫃)

7	TOLERANCE GRADE ** B **	A	B	DIM.	MM	DRN.	DATE	TITLE
8	~6	0.05	0.1	Army	3-31-98			204AL
9	6~18	0.08	0.18	CHK.				
10	18~50	0.1	0.25					
11	50~180	0.2	0.4	MODULE LCM				
12	180~	0.3	0.5	204AL				

1	VSS	9	DB2
2	VDD <td>10</td> <td>DB3</td>	10	DB3
3	VO <td>11</td> <td>DB4</td>	11	DB4
4	RS <td>12</td> <td>DB5</td>	12	DB5
5	R/W <td>13</td> <td>DB6</td>	13	DB6
6	E <td>14</td> <td>DB7</td>	14	DB7
7	DB0 <td>15</td> <td>A</td>	15	A
8	DB1 <td>16</td> <td>K</td>	16	K

7	TOLERANCE GRADE(±)
8	~6
9	6~18
10	18~50
11	50~180
12	180~

7	DATE	DATE
8	3-31-98	
9		
10		
11		
12		

DRN.	CHK.	APPD.
Army		

DWG. NO.	SHEET
*980351MF	1 OF 1