

Preliminary

The contents of this document are confidential and must not be disclosed wholly or in part to any third part without the prior written consent of AMPIRE CO., LTD



**晶采光電科技股份有限公司
AMPIRE CO., LTD.**

SPECIFICATIONS FOR LCD MODULE

CUSTOMER	
CUSTOMER PART NO.	
AMPIRE PART NO.	AM-800600LTNQW-T02H
APPROVED BY	
DATE	

Approved For Specifications

Approved For Specifications & Sample

AMPIRE CO., LTD.

**2F., No.88, Sec. 1, Sintai 5th Rd., Sijih City, Taipei County 221, Taiwan
(R.O.C.)台北縣汐止市新台五路一段 88 號 2 樓(東方科學園區 D 棟)**

TEL:886-2-26967269 , FAX:886-2-26967196 or 26967270

APPROVED BY	CHECKED BY	ORGANIZED BY

Preliminary

The contents of this document are confidential and must not be disclosed wholly or in part to any third part without the prior written consent of AMPIRE CO., LTD

RECORD OF REVISION

Revision Date	Page	Contents	Editor
2009/11/02	-	New Release	JOHN
2010/03/24	-	Issued the official Part No. to AM-800600LTNQW-T02H.	Emil

Preliminary

The contents of this document are confidential and must not be disclosed wholly or in part to any third part without the prior written consent of AMPIRE CO., LTD

1. INSTRUCTION

Ampire 10.4" Display Module is a color active matrix TFT-LCD that uses amorphous silicon TFT as a switching device . This model is composed of a TFT-LCD panel , a driving circuit, projected capacitive touch panel and Evaluation Kit. This TFT-LCD has a high resolution (800(R.G.B) X 600) and can display up to 262,144 colors.

1.1 Features

- (1) Construction : a-Si TFT-LCD with driving system, White LED Backlight.
- (2) LCD type : Transmissive , Normally White
- (3) Number of the Colors : 262K colors (R,G,B 6 bit digital each)
- (4) Projected capacitive touch panel & Evaluation Kit.
- (5) LVDS Interface.
- (6) LCD Power Supply Voltage: 3.3V single power input, built-in power supply circuit.

2. PHYSICAL SPECIFICATIONS

Item	Specifications	unit
Display resolution(dot)	800RGB (W) x 600(H)	dots
Active area	211.2 (W) x 158.4(H)	mm
Pixel pitch	88 (W) x 264 (H)	um
Color configuration	R.G.B -stripe	
Overall dimension	240.9403(W)x190.13(H)x16.04(D)	mm
Backlight unit	LED	
Display color	262,144	colors

Preliminary

The contents of this document are confidential and must not be disclosed wholly or in part to any third part without the prior written consent of AMPIRE CO., LTD

3. ABSOLUTE MAXIMUM RATINGS

Item	Symbol	Min.	Max.	Unit	Note
Supply voltage range	VDD	-0.5	5	V	
Voltage range at any terminal	V _{IN}	-0.5	5	V	(1)
Operating Temperature	Top	-20	70	°C	
Storage Temperature	Tstg	-30	80	°C	

Note

(1): V_{IN} represents IN0±, IN1±, IN2±, CLK±

4. OPTICAL CHARACTERISTICS

Item	Symbol	Conditon	Min.	Typ.	Max.	Unit	Note	
Response Time	T _r +T _f	$\Theta = \Phi = 0^\circ$	-	25	40	ms	(1)	
Contrast ratio	CR		300	400	-	-	(2)(3)	
Viewing Angle	ΘT	CR \geq 10	35	45	-	degree	(5)	
	ΘB		55	65	-			
	ΘL		55	65	-			
	ΘR		55	65	-			
Luminance	L	$\Theta = \Phi = 0^\circ$	280	320	-	cd/m ²	(3)(4)	
Luminance Uniformity	ΔL		-	80	-	%	(3)(4)	
Color chromaticity	Red		R _x	0.550	0.600	0.650	-	
			R _y	0.296	0.346	0.396	-	
	Green		G _x	0.283	0.333	0.383	-	
			G _y	0.516	0.566	0.616	-	
	Blue		B _x	0.092	0.142	0.192	-	
			B _y	0.065	0.115	0.165	-	
	White		W _x	0.259	0.309	0.359	-	
			W _y	0.284	0.334	0.384	-	

NOTE :

- These items are measured by BM-5A(TOPCON) or CA-1000(MINOLTA) in the dark room (no ambient light)

Preliminary

The contents of this document are confidential and must not be disclosed wholly or in part to any third part without the prior written consent of AMPIRE CO., LTD

(1) Definition of Response Time (White-Black)

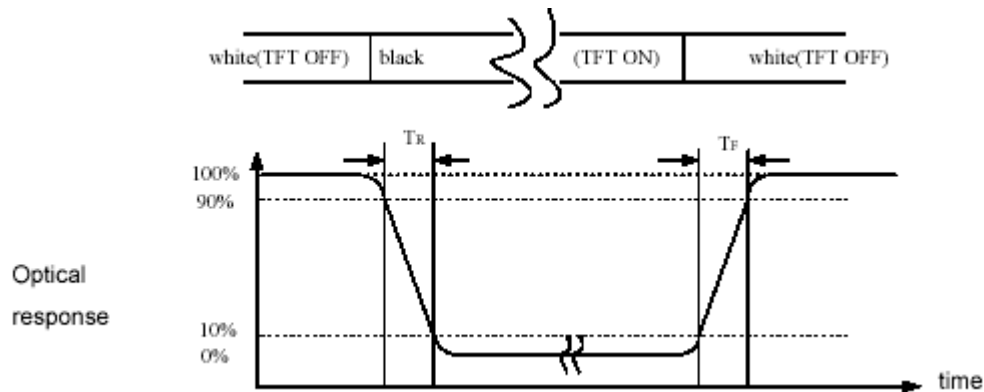

(2) Definition of Contrast Ratio

Measure contrast ratio on the below 5 points(refer to figure1,#1~#5point) and take the average value

Contrast ratio is calculated with the following formula :

$$\text{Contrast Ratio(CR)} = (\text{White})\text{Luminance of ON} \div (\text{Black})\text{Luminance of OFF}$$

(3) Definition of Luminance :

Measure the luminance of white state at **center point**.

(4) Definition of Luminance Uniformity :

Measured Maximum luminance[L(MAX)] and Minimum luminance[L(MIN)] on the 5 points

Luminance Uniformity is calculated with the following formula :

$$\Delta L = [L(\text{MIN}) / L(\text{MAX})] \times 100\%$$

(5) Definition of Viewing Angle

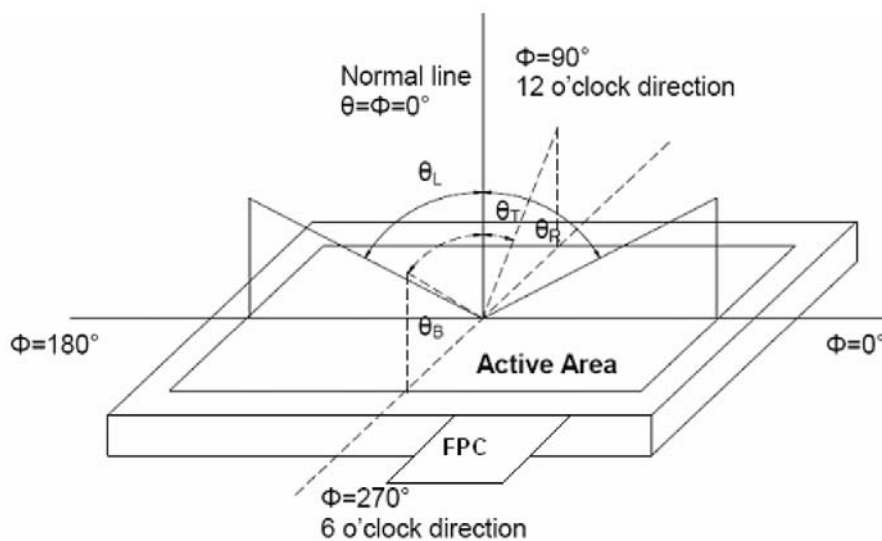

Preliminary

The contents of this document are confidential and must not be disclosed wholly or in part to any third part without the prior written consent of AMPIRE CO., LTD

5. ELECTRICAL CHARACTERISTICS

5.1 LVDS electrical characteristic

Item	Symbol	Min.	Typ.	Max	Unit	Remarks
LVDS Differential input high threshold	V_{TH}	-	-	100	mV	$V_{CMLVDS}=1.2V$
LVDS Differential input low Threshold	V_{TL}	-100	-	-	mV	
Differential input voltage	$ V_{ID} $	0.1	-	0.6	V	
LVDS input common mode Voltage	V_{CMLVDS}	$ V_{ID} /2$	-	$1.4-(V_{ID} /2)$	V	
Input current	I_{IN}	-10	-	10	μA	
Supply Voltage	VDD	3.0	3.3	3.6	V	
Common Electrode Driving Signal	VCOM	-	4.36	-	V	Note1
Sync Frequency	FVD	-	60	70	Hz	
VDD Power Consumption	I_{DD}	-	260	380	mA	Note2

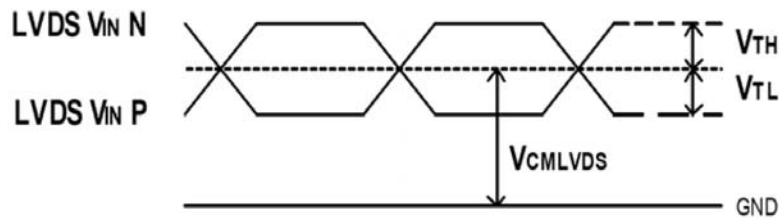

LVDS DC timing diagram

Note1: The value may be different for different LCM.

Note2: To test the current dissipation, using the “color bar” testing pattern shown as below:

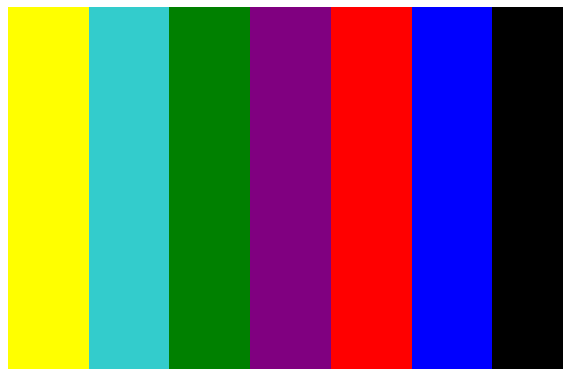

Current dissipation testing pattern

Preliminary

The contents of this document are confidential and must not be disclosed wholly or in part to any third part without the prior written consent of AMPIRE CO., LTD

5.2 Touch Panel & Extreme Touch Projected Capacitive Evaluation Kit

5.21 Projected Capacitive Touch Panel

Electrical Characteristics

Input Method : Finger Simulated stylus.

Insulation Impedance: Exceeds 20 Meg ohm or more at DC 10V

Positional Accuracy: $\pm 1.5\%$ in X and Y position within the viewing area (typical).

5.22 Durability Characteristics

Touch Durability: 300 million touches at a single point with 350 gram force.

5.23 Environmental Characteristics

Operation Conditions: High temperature and relative humidity (RH): tested at +50 °C at 90% RH non-condensing for 240 hours
Low and high temperature : -20°C~70 °C, 50% relative humidity, non-condensing

Storage Conditions : Low and high temperature : -30°C~80 °C, 50% relative humidity, non-condensing

Preliminary

The contents of this document are confidential and must not be disclosed wholly or in part to any third part without the prior written consent of AMPIRE CO., LTD

5.22 Extreme Touch Projected Capacitive Evaluation Kit

Capacitive evaluation kit is equipped with a general purpose projected capacitive controller and touch screen designed to provide a complete product solution.

Features

Motion Detection Method	Capacitive Sensing
X/Y Position Reporting	Absolute Position
Touch Force	No contact pressure required.
HID	HID Compliant
Calibration	No need for calibration.
Touch	Single Touch and Gesture (Two Finger Touch)
Controller Size	2.0" x 2.0" (50.80mm x 50.8mm)
Interface	USB: 2.0, 1.1 Compliant (Standard)
Communication Cables	A Plug/5-Pin Mini-B Plug (USB & USB-UART): TI# 1300264
Report Rate	Approx 25 - 50 Points / Sec
Mean Time between Failures	> 5.6 Million hrs.
Supported Operating Systems	Windows 2000, XP, Vista and 7; Linux Ubuntu; Mac OSX 10.X (Leopard)

Advantages

- 1.Ease to Use just Plug and Play
- 2.Reduce the Risk of Noise Interference
- 3.Protect the Touch Screen and Controller from Damage

Preliminary

The contents of this document are confidential and must not be disclosed wholly or in part to any third part without the prior written consent of AMPIRE CO., LTD

6. Backlight Driving Circuit

ITEM	SYMBOL	MIN	TYP	MAX	UNIT	NOTE
Forward Current	I_F	-	120.0	-	0A	Note 1
Forward Voltage	V_F	-	19.2	-	V	Note 1
Backlight Power Consumption	W_{BL}	-	2304	-	mW	Note 1

Note 1: LED connection of backlight shown as below:

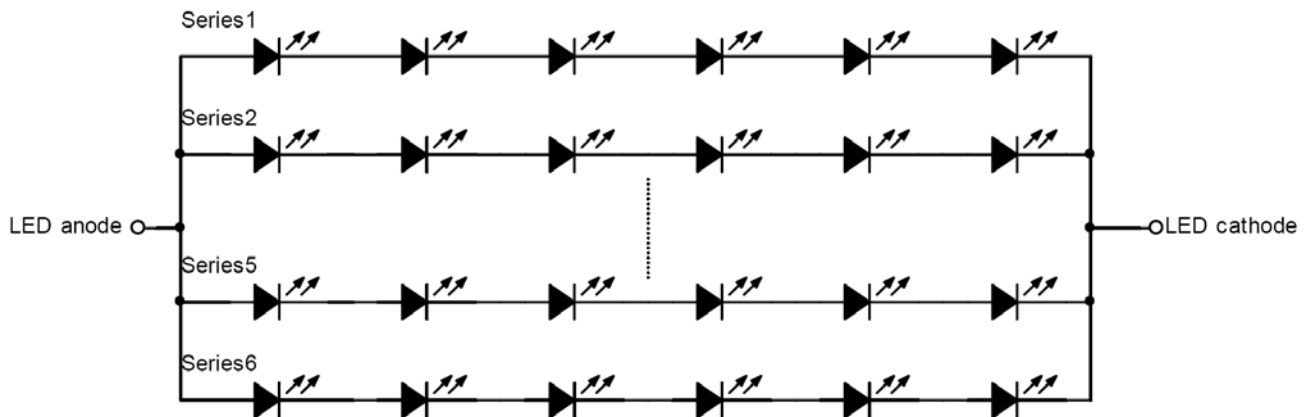

Note2: One LED: $I_F = 120\text{mA}$.

Note3: The Life of LED: 20,000hrs.

Preliminary

The contents of this document are confidential and must not be disclosed wholly or in part to any third part without the prior written consent of AMPIRE CO., LTD

7. INTERFACE

LVDS CN:

Matching connector of Hirose DF19K-20P-1H (56)

Pin no	Symbol	Function
1	VDD	POWER SUPPLY:3.3V
2	VDD	POWER SUPPLY:3.3V
3	Gnd	Power Ground
4	Gnd	Power Ground
5	IN0-	Transmission Data of Pixels
6	IN0+	Transmission Data of Pixels
7	Gnd	Power Ground
8	IN1-	Transmission Data of Pixels 1
9	IN1+	Transmission Data of Pixels 1
10	Gnd	Power Ground
11	IN2-	Transmission Data of Pixels 2
12	IN2+	Transmission Data of Pixels 2
13	Gnd	Power Ground
14	CLK-	Sampling Clock
15	CLK+	Sampling Clock
16	Gnd	Power Ground
17	NC	No Connect
18	NC	No Connect
19	Gnd	Power Ground
20	Gnd	Power Ground

Back Light Connector:

Pin no	Symbol	Function	Wire Color
1	VL1	LED driving anode (high voltage)	Red
2	VL2	LED driving cathode (low voltage)	White

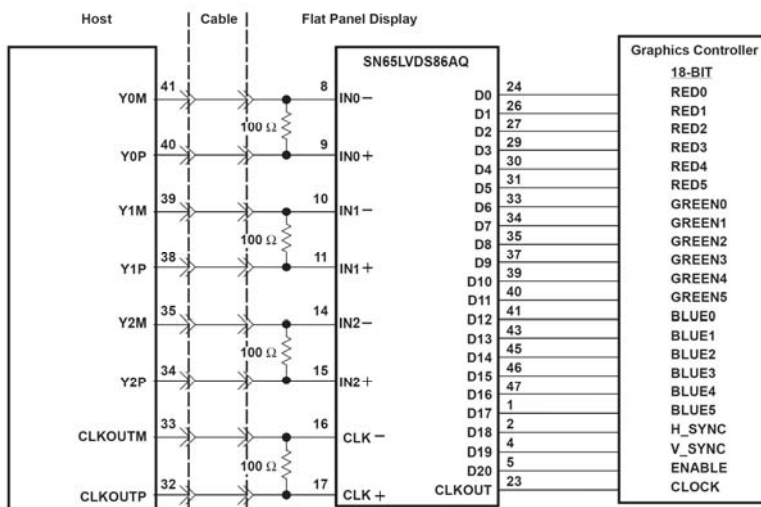

Preliminary

The contents of this document are confidential and must not be disclosed wholly or in part to any third party without the prior written consent of AMPIRE CO., LTD

8. AC Timing characteristic of the LVDS

Timing Parameter:

Item	Symbol	Min	Typ	Max	Unit	Condition
Clock period	tLVCP	20.0	25	31.25	ns	
Clock high time	tLVCH	-	14.29	-	ns	
Clock low time	tLVCL	-	10.71	-	ns	
PLL wake-up time	tLVPLL	-	-	1	ms	
Input skew margin	tLVSKM	400	-	-	ps	f=85MHz

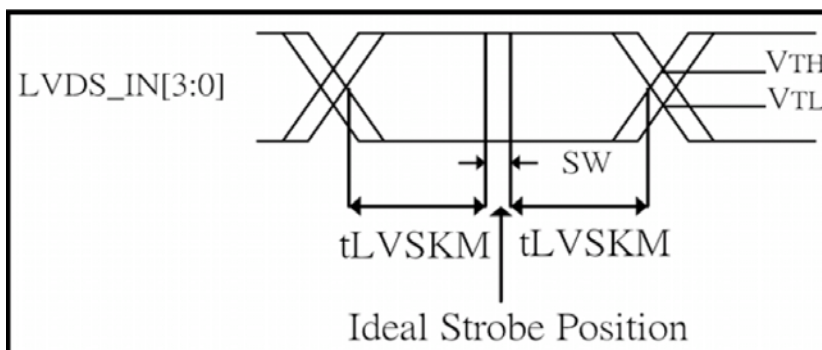
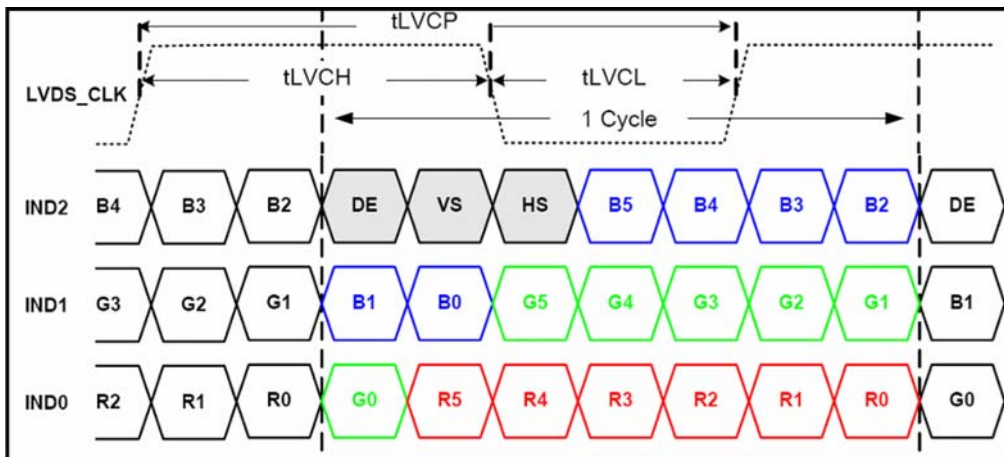
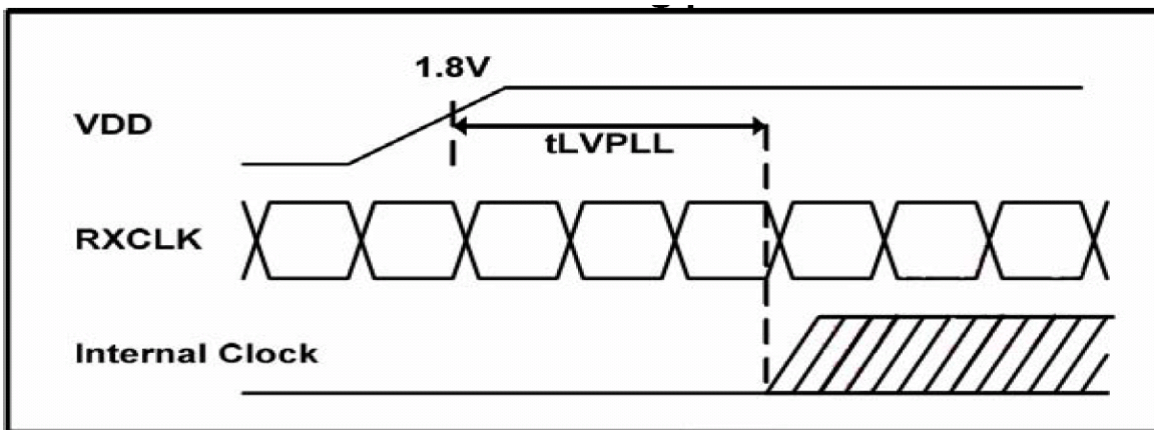

Setup and Hold time

Preliminary

The contents of this document are confidential and must not be disclosed wholly or in part to any third part without the prior written consent of AMPIRE CO., LTD

Power On/Off Sequence

Item	Symbol	Min	Typ	Max	Unit	Remark
VDD 3.0V to signal starting	Tp1	0	-	50	ms	
Signal starting to backlight on	Tp2	150	-	-	ms	
Signal off to VDD 3.0V	Tp3	0	-	50	ms	
Backlight off to signal off	Tp4	150	-	-	ms	

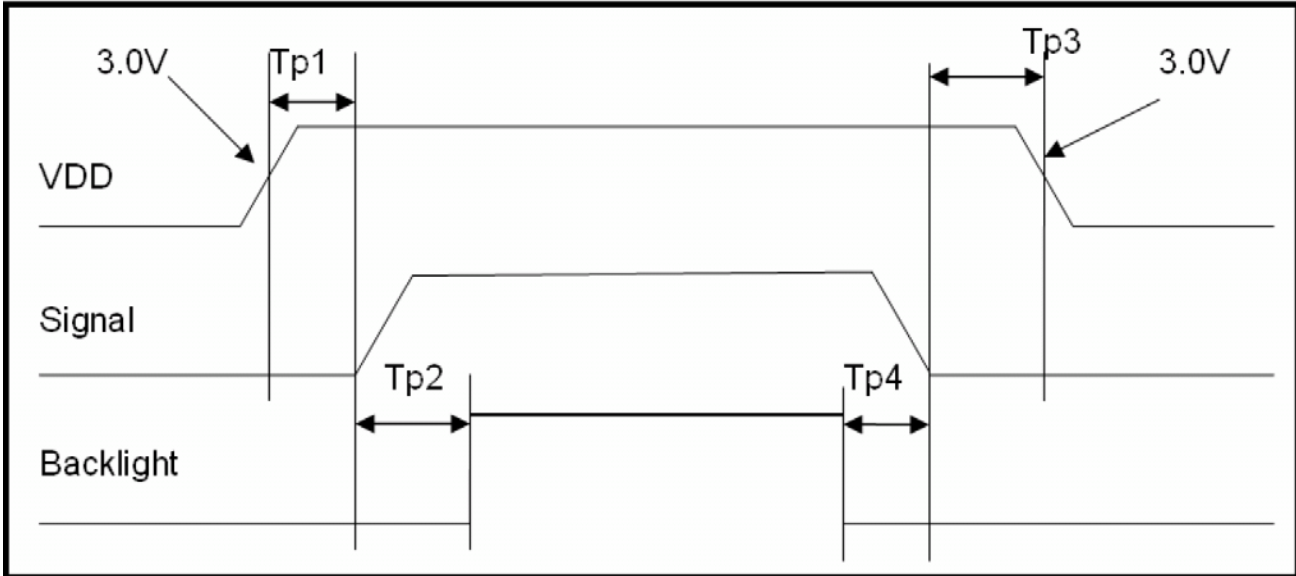

Preliminary

The contents of this document are confidential and must not be disclosed wholly or in part to any third part without the prior written consent of AMPIRE CO., LTD

9 . QUALITY AND RELIABILITY

9.1 TEST CONDITIONS

Tests should be conducted under the following conditions :

Ambient temperature : $25 \pm 5^{\circ}\text{C}$

Humidity : $60 \pm 25\% \text{ RH.}$

9.2 SAMPLING PLAN

Sampling method shall be in accordance with MIL-STD-105E , level II, normal single sampling plan .

9.3 ACCEPTABLE QUALITY LEVEL

A major defect is defined as one that could cause failure to or materially reduce the usability of the unit for its intended purpose. A minor defect is one that does not materially reduce the usability of the unit for its intended purpose or is an infringement from established standards and has no significant bearing on its effective use or operation.

9.4 APPEARANCE

An appearance test should be conducted by human sight at approximately 30 cm distance from the LCD module under florescent light. The inspection area of LCD panel shall be within the range of following limits.

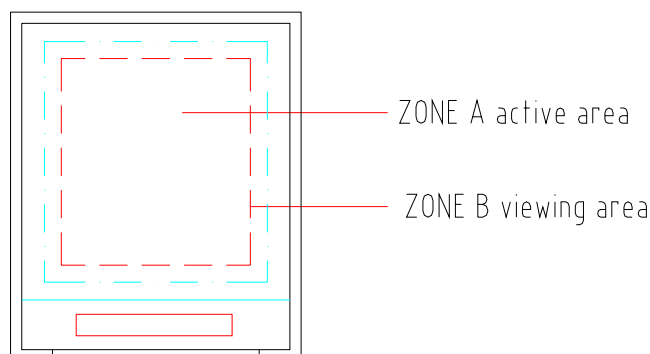

Preliminary

The contents of this document are confidential and must not be disclosed wholly or in part to any third part without the prior written consent of AMPIRE CO., LTD

9.5 INCOMING INSPECTION STANDARD FOR TFT-LCD PANEL

DEFECT TYPE		LIMIT		Note				
VISUAL DEFECT	INTERNAL	SPOT	$\phi < 0.15\text{mm}$	Ignore	Note1			
			$0.15\text{mm} \leq \phi \leq 0.5\text{mm}$	$N \leq 4$				
			$0.5\text{mm} < \phi$	$N=0$				
		FIBER	$0.03\text{mm} < W \leq 0.1\text{mm}, L \leq 5\text{mm}$	$N \leq 3$	Note1			
			$1.0\text{mm} < W, 1.5\text{mm} < L$	$N=0$				
		POLARIZER BUBBLE	$\phi < 0.15\text{mm}$	Ignore	Note1			
	$0.15\text{mm} \leq \phi \leq 0.5\text{mm}$		$N \leq 2$					
	$0.5\text{mm} < \phi$		$N=0$					
Mura	It' OK if mura is slight visible through 6%ND filter							
ELECTRICAL DEFECT	BRIGHT DOT	A Grade			B Grade			
		C Area	O Area	Total	C Area	O Area	Total	Note3
	$N \leq 0$	$N \leq 2$	$N \leq 2$	$N \leq 2$	$N \leq 3$	$N \leq 5$	Note2	
	DARK DOT	$N \leq 2$	$N \leq 3$	$N \leq 3$	$N \leq 3$	$N \leq 5$	$N \leq 8$	
	TOTAL DOT	$N \leq 4$			$N \leq 5$	$N \leq 6$	$N \leq 8$	Note2
	TWO ADJACENT DOT	$N \leq 0$	$N \leq 1$ pair	$N \leq 1$ pair	$N \leq 1$ pair	$N \leq 1$ pair	$N \leq 1$ pair	Note4
	THREE OR MORE ADJACENT DOT	NOT ALLOWED						
	LINE DEFECT	NOT ALLOWED						

(1) One pixel consists of 3 sub-pixels, including R,G, and B dot.(Sub-pixel = Dot)

(2) LITTLE BRIGHT DOT ACCEPTABLE UNDER 6 % ND-Filter

[Note1] W : Width[mm], L : Length[mm], N : Number, ϕ : Average Diameter

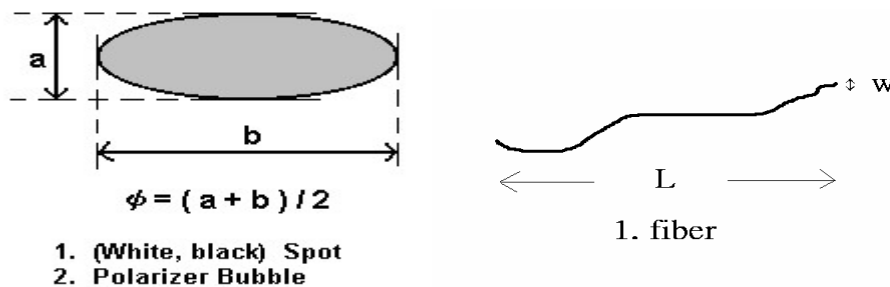

[Note2] Bright dot is defined through 6% transmission ND Filter as following.

Preliminary

The contents of this document are confidential and must not be disclosed wholly or in part to any third part without the prior written consent of AMPIRE CO., LTD

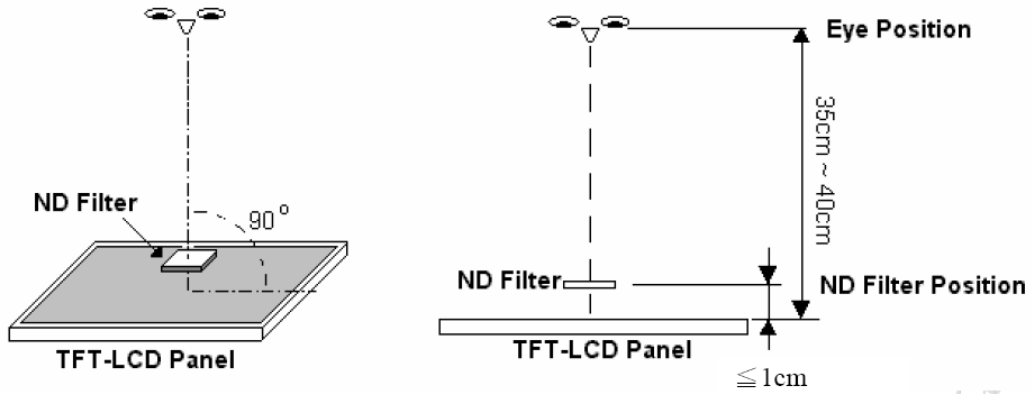

[Note3]

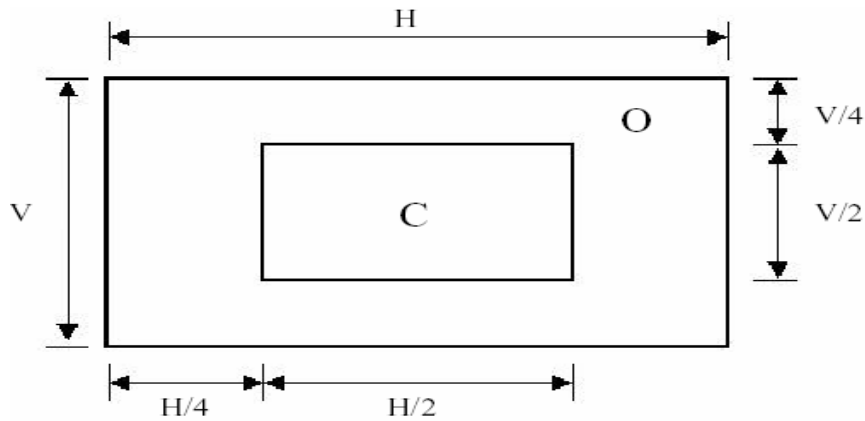

C Area: Center of display area
C Area: Outer of display area

[Note4]

Judge defect dot and adjacent dot as following. Allow below (as A, B, C and D status) adjacent defect dots, including bright and dart adjacent dot. And they will be counted 2 defect dots in total quantity.

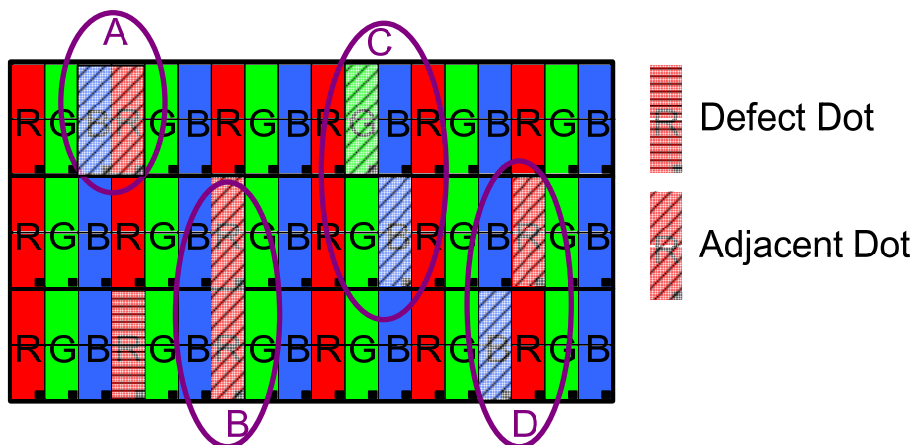

- (1) The defects that are not defined above and considered to be problem shall be reviewed and discussed by both parties.
- (2) Defects on the Black Matrix, out of Display area, are not considered as a defect or counted.

Preliminary

The contents of this document are confidential and must not be disclosed wholly or in part to any third part without the prior written consent of AMPIRE CO., LTD

9.6 Reliability Test

Test Item	Test Conditions	Note
High Temperature Operation	70±3°C , t=96 hrs	
Low Temperature Operation	-20±3°C , t=96 hrs	
High Temperature Storage	80±3°C , t=96 hrs	1,2
Low Temperature Storage	-30±3°C , t=96 hrs	1,2
Thermal Shock Test	-20°C ~ 25°C ~ 70°C 30 m in. 5 min. 30 min. (1 cycle) Total 5 cycle	1,2
Humidity Test	60 °C, Humidity 90%, 96 hrs	1,2
Vibration Test (Packing)	Sweep frequency : 10 ~ 55 ~ 10 Hz/1min Amplitude : 0.75mm Test direction : X.Y.Z/3 axis Duration : 30min/each axis	2

Note 1 : Condensation of water is not permitted on the module.

Note 2 : The module should be inspected after 1 hour storage in normal conditions
(15-35°C , 45-65%RH).

Definitions of life end point :

- Current drain should be smaller than the specific value.
- Function of the module should be maintained.
- Appearance and display quality should not have degraded noticeably.
- Contrast ratio should be greater than 50% of the initial value.

Preliminary

The contents of this document are confidential and must not be disclosed wholly or in part to any third part without the prior written consent of AMPIRE CO., LTD

10. USE PRECAUTIONS

10.1 Handling precautions

- 1) The polarizing plate may break easily so be careful when handling it. Do not touch, press or rub it with a hard-material tool like tweezers.
- 2) Do not touch the polarizing plate surface with bare hands so as not to make it dirty. If the surface or other related part of the polarizing plate is dirty, soak a soft cotton cloth or chamois leather in benzine and wipe off with it. Do not use chemical liquids such as acetone, toluene and isopropyl alcohol. Failure to do so may bring chemical reaction phenomena and deteriorations.
- 3) Remove any spit or water immediately. If it is left for hours, the suffered part may deform or decolorize.
- 4) If the LCD element breaks and any LC stuff leaks, do not suck or lick it. Also if LC stuff is stuck on your skin or clothing, wash thoroughly with soap and water immediately.

10.2 Installing precautions

- 1) The PCB has many ICs that may be damaged easily by static electricity. To prevent breaking by static electricity from the human body and clothing, earth the human body properly using the high resistance and discharge static electricity during the operation. In this case, however, the resistance value should be approx. $1M\Omega$ and the resistance should be placed near the human body rather than the ground surface. When the indoor space is dry, static electricity may occur easily so be careful. We recommend the indoor space should be kept with humidity of 60% or more. When a soldering iron or other similar tool is used for assembly, be sure to earth it.
- 2) When installing the module and ICs, do not bend or twist them. Failure to do so may crack LC element and cause circuit failure.
- 3) To protect LC element, especially polarizing plate, use a transparent protective plate (e.g., acrylic plate, glass etc) for the product case.
- 4) Do not use an adhesive like a both-side adhesive tape to make LCD surface (polarizing plate) and product case stick together. Failure to do so may cause the polarizing plate to peel off.

10.3 Storage precautions

- 1) Avoid a high temperature and humidity area. Keep the temperature between 0°C and 35°C and also the humidity under 60%.
- 2) Choose the dark spaces where the product is not exposed to direct sunlight or fluorescent light.
- 3) Store the products as they are put in the boxes provided from us or in the same

Preliminary

The contents of this document are confidential and must not be disclosed wholly or in part to any third part without the prior written consent of AMPIRE CO., LTD

conditions as we recommend.

10.4 Operating precautions

- 1) Do not boost the applied drive voltage abnormally. Failure to do so may break ICs. When applying power voltage, check the electrical features beforehand and be careful. Always turn off the power to the LC module controller before removing or inserting the LC module input connector. If the input connector is removed or inserted while the power is turned on, the LC module internal circuit may break.
- 2) The display response may be late if the operating temperature is under the normal standard, and the display may be out of order if it is above the normal standard. But this is not a failure; this will be restored if it is within the normal standard.
- 3) The LCD contrast varies depending on the visual angle, ambient temperature, power voltage etc. Obtain the optimum contrast by adjusting the LC drive voltage.
- 4) When carrying out the test, do not take the module out of the low-temperature space suddenly. Failure to do so will cause the module condensing, leading to malfunctions.
- 5) Make certain that each signal noise level is within the standard (L level: $0.2V_{dd}$ or less and H level: $0.8V_{dd}$ or more) even if the module has functioned properly. If it is beyond the standard, the module may often malfunction. In addition, always connect the module when making noise level measurements.
- 6) The CMOS ICs are incorporated in the module and the pull-up and pull-down function is not adopted for the input so avoid putting the input signal open while the power is ON.
- 7) The characteristic of the semiconductor element changes when it is exposed to light emissions, therefore ICs on the LCD may malfunction if they receive light emissions. To prevent these malfunctions, design and assemble ICs so that they are shielded from light emissions.
- 8) Crosstalk occurs because of characteristics of the LCD. In general, crosstalk occurs when the regularized display is maintained. Also, crosstalk is affected by the LC drive voltage. Design the contents of the display, considering crosstalk.

10.5 Other

- 1) Do not disassemble or take the LC module into pieces. The LC modules once disassembled or taken into pieces are not the guarantee articles.
- 2) The residual image may exist if the same display pattern is shown for hours. This residual image, however, disappears when another display pattern is shown or the drive is interrupted and left for a while. But this is not a problem on reliability.
- 3) AMIPRE will provide one year warranty for all products and three months warrantee for all repairing products.

Preliminary

The contents of this document are confidential and must not be disclosed wholly or in part to any third part without the prior written consent of AMPIRE CO., LTD

11. OUTLINE DIMENSION

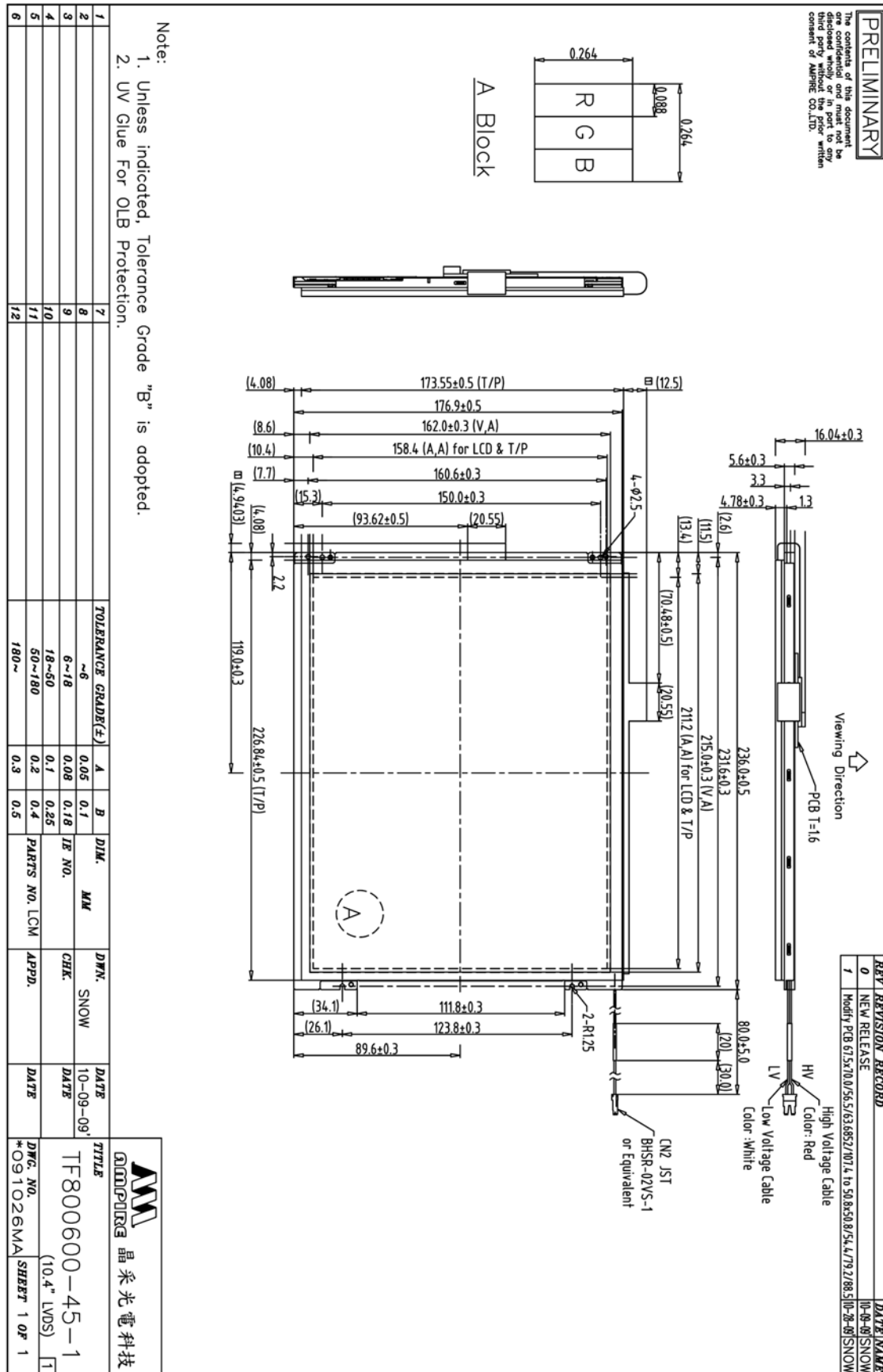

Preliminary

The contents of this document are confidential and must not be disclosed wholly or in part to any third party without the prior written consent of AMPIRE CO., LTD

