



Monolithic Power Systems

MP2498, 2A Step-Down Regulator w/ Integrated 100V Load Dump Protection

What is it?

MP2498 is a 2A, High-Voltage Non-Sync Buck with Integrated 100V Load Dump Protection

Applications

- Avionics Power
- Automotive Cigarette Lighter Adaptor
- Power Supply for Linear Chargers
- Industrial Power Systems
- Distributed Power Systems



Avionics



CLA Adaptor



Automobile

www.monolithicpower.com

MPS 2498

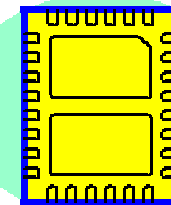

Power Supply



Monolithic Power Systems

MP2498, 2A Step-Down Regulator w/ Integrated 100V Load Dump Protection

Features

- Replaces External Transorb and fuse
- Input Surge Protection Up to 100V
- Continuous Input Voltage 5-24V
- Output Adjustable from 0.8V to 15V
- High-Efficiency Light-Load Operation
- 95% Efficiency @ 500mA ($V_o=5V$)
- 150kHz to 2MHz programmable Frequency
- Cycle-by-Cycle Over Current Protection
- Available in a 28-Pin QFN Package

Benefits

- **Integrated solution for load Dump Protection**
- Advanced DMOS process and structure for superb SOA
- Reduce package profile
- Reduce product cost
- Safety operation

Typical Application

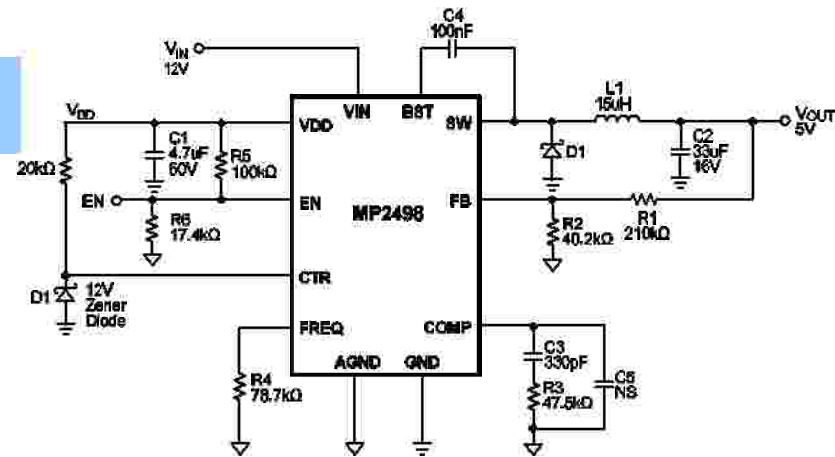

TOP VIEW

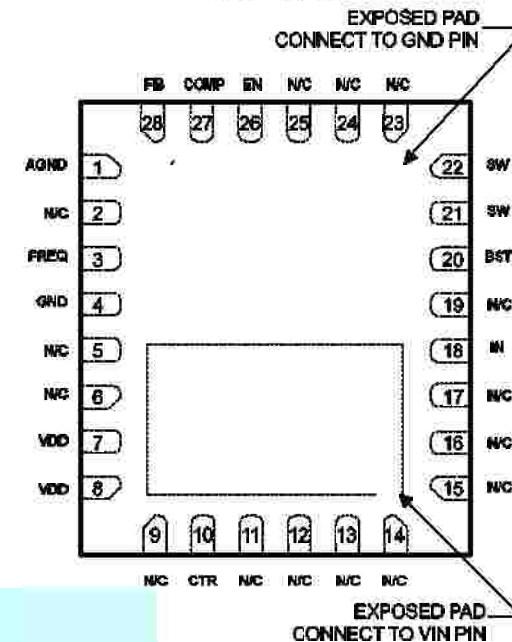

MPS Solution: Small & Cost Effective!